Operating, Programming and Servicing Manual

HP 8116A 50 MHz Programmable Pulse/Function Generator

SERIAL NUMBERS

This manual applies directly to instrument serial number 3134G11521. If your instrument has a higher serial number, refer to Appendix C which contains manual changes for later instruments and corrections to the manual. Be sure to examine this supplement for changes which apply to your instrument, and record these changes in the manual. If your instrument has a lower serial number, refer to Appendix B which contains manual changes for earlier instruments.



HP Part No. 08116-90014

Printed in Federal Republic of Germany September 1993

Second Edition

E0993

Notice

Subject Matter Notice

The information in this document is subject to change without notice.

Hewlett-Packard makes no warranty of any kind with regard to this printed material, including, but not limited to, the implied warranties of merchantability and fitness for a particular purpose.

Hewlett-Packard shall not be liable for errors contained herein or for incidental or consequential damages in connection with the furnishing, performance or use of this material.

Copyright

This document contains proprietary information which is protected by copyright. All rights are reserved. No part of this document may be photocopied, reproduced or translated into another language without the prior consent of Hewlett-Packard GmbH.

Customer Comment Card

HP 8116A Operating, Programming and Servicing Manual

Part No.: 08116-90004

We welcome your evaluation of this manual. Your comments and suggestions will help us improve our publications. Attach additional pages if necessary.

Please circle the following Yes or No:

- | | | |
|--|-----|----|
| ■ Is the table of contents comprehensive enough? | Yes | No |
| ■ Is the index comprehensive enough? | Yes | No |
| ■ Is the manual well organized? | Yes | No |
| ■ Are the chapter and section headings relevant? | Yes | No |
| ■ In general, is information easy to find? | Yes | No |
| ■ Is the information technically accurate? | Yes | No |
| ■ Are instructions complete? | Yes | No |
| ■ Are concepts and wording easy to understand? | Yes | No |
| ■ Are the examples appropriate and helpful? | Yes | No |
| ■ Are there enough examples? | Yes | No |
| ■ Are there enough helpful illustrations? | Yes | No |
| ■ Do you need a glossary of terms? | Yes | No |

Additional Comments: _____

Please provide:

Name: _____ Title: _____

Company: _____

Address: _____

Please send to :



Just remove this card, fold so that the pre-addressed label is on the outside, secure and mail.
Thank you for your assistance.

Tape here

PLEASE DO NOT STAPLE

Tape here

.... Fold here.....Fold here....



.....
.
. FIX .
. STAMP .
. HERE .
.....

Hewlett-Packard GmbH
BID Marketing PL24
Herrenbergerstrasse 130
D-7030 Boeblingen

GERMANY

Printing History

New editions are complete revisions of the manual. Update packages, which are issued between editions, contain additional and replacement pages to be merged into the manual by the customer. The date on the title page and back cover of the manual only changes when a new edition is published. When an edition is reprinted, all the prior updates to the edition are incorporated. No information is incorporated into a new edition unless it appears in a prior update.

Edition	Print Date	Manual Part No.	
1	November 1982	08116-90001	E1182
1	June 1984	08116-90002	E0684
1	August 1990	08116-90003	E0890
1	July 1991	08116-90004	E0791
2	September 1993	08116-90014	E0993

Safety

This product has been designed and tested according to International Safety Requirements. To ensure safe operation and to keep the product safe, the information, cautions and warnings in this manual must be heeded.

Preface

Introduction This manual describes the following procedures for the HP 8116A 50MHz Programmable Pulse/Function Generator:

- Installing
- Operating
- Programming
- Testing Performance
- Adjustment Procedures
- Servicing

Certification Hewlett-Packard Company certifies that this product met its published specifications at the time of shipment from the factory. Hewlett-Packard further certifies that its calibration measurements are traceable to the United States National Institute of Standards and Technology, to the extent allowed by the Institute's calibration facility, and to the calibration facilities of other International Standards Organization members.

Warranty This Hewlett-Packard instrument product is warranted against defects in material and workmanship for a period of one year from date of shipment. During the warranty period, HP will, at its option, either repair or replace products which prove to be defective.

For warranty service or repair, this product must be returned to a service facility designated by HP. The Buyer shall prepay shipping charges to HP and HP shall pay shipping charges to return the product to the Buyer. However, the Buyer shall pay all shipping charges, duties, and taxes for products returned to HP from another country.

HP warrants that its software and firmware designated by HP for use with an instrument will execute its programming instructions when properly installed on that instrument. HP does not warrant that the operation of the instrument, software, or firmware will be uninterrupted or error free.

Limitation of Warranty The foregoing warranty shall not apply to defects resulting from improper or inadequate maintenance by the Buyer, Buyer-supplied software or interfacing, unauthorized modification or misuse, operation outside of the environmental specifications for the product, or improper site preparation or maintenance.

No other warranty is expressed or implied. HP specifically disclaims the implied warranties of Merchantability and Fitness for a Particular Purpose.

Exclusive Remedies

The remedies provided herein are the Buyer's sole and exclusive remedies. HP shall not be liable for any direct, indirect, special, incidental, or consequential damages, whether based on contract, tort, or any other legal theory.

Assistance

Product maintenance agreements and other customer assistance agreements are available for Hewlett-Packard products. For any assistance, contact your nearest Hewlett-Packard Sales and Service Office. Addresses are provided at the back of this manual.

Contents

1. Introduction	
General	1-1
Instruments Covered by This Manual	1-1
Instrument Description	1-2
HP 8116A Options	1-2
Accessories	1-3
Recommended Test Equipment	1-3
2. Specifications	
Introduction	2-1
Timing Parameters	2-2
Output Parameters	2-4
Waveform Characteristics	2-5
Operating Characteristics	2-6
Trigger Modes	2-6
Control Modes	2-8
Output modes	2-9
Inputs and Outputs	2-10
Additional Features	2-12
General Characteristics	2-13
3. Installation	
Introduction	3-1
Safety Considerations	3-1
Initial Inspection	3-1
Power Requirements and Line Voltage Selection	3-2
Power Cable	3-3
HP-IB Connector	3-5
HP-IB Logic Levels	3-5
Operating Environment	3-6
Temperature	3-6
Claims and Repackaging	3-6
Storage and Shipment	3-7
Return Shipment to HP	3-7

4. Operating	
Introduction	4-1
Switching On	4-2
Standard Parameter Set	4-3
Selecting Trigger Mode	4-4
Controlling the External Trigger	4-6
Selecting Control Mode	4-7
Selecting Output Waveform	4-11
Setting Parameters	4-12
Selecting Output Mode	4-15
Rear Panel	4-16
5. Operating Examples	
Introduction	5-1
Normal Mode	5-2
Trig Mode	5-3
Gate Mode	5-5
External Width Mode	5-6
Sweep Modes	5-7
Burst Modes	5-9
6. Programming	
General	6-1
Setting the HP-IB Address	6-1
Local, Remote and Local Lockout	6-2
Introduction	6-3
Selecting Trigger Modes	6-4
Selecting Control Modes	6-5
Selecting Output Waveform	6-5
Setting Parameters	6-6
Autovernier	6-8
Reading parameters	6-9
Selecting Output Modes	6-10
Reading the Current Settings	6-11
Timing	6-12
Error, Fault and Status Reporting	6-13
HP-IB Status Byte	6-13
Timing Error (Bit 0)	6-14
Programming Error (Bit 1)	6-15
Syntax Error (Bit 2)	6-15
System Failure (Bit 3)	6-15
Autovernier in Progress (Bit 4)	6-16
Sweep in Progress (Bit 5)	6-16
Service Request (Bit 6)	6-16
Buffer not Empty (Bit 7)	6-16
HP-IB Universal Commands	6-17

7. Programming Examples	
Introduction	7-1
Testing communication	7-2
Performing self-test	7-4
Using the Buffer Not Empty Flag	7-6
Using the Autovernier	7-8
8. Testing Performance	
Introduction	8-1
Performance Tests	8-1
Verification Tests	8-1
Test Equipment	8-1
Test Record	8-1
Frequency Performance Test	8-2
Duty Cycle Performance Test	8-4
Pulse Width Performance Test	8-6
Amplitude & Offset Performance Test	8-8
Sine Waveform Performance Test	8-10
Pulse/Squarewave Performance Test	8-14
DC Output Performance Test	8-16
Trigger, Gate and External Width Verification Test	8-18
Burst Modes Verification Test (Opt 001)	8-20
Characteristics	8-20
Frequency Modulation Verification Test	8-22
Amplitude Modulation Verification Test	8-24
Pulse Width Modulation Verification Test	8-26
Sweep Modes Verification Test (Opt 001)	8-28
Autovernier and Output Mode Verification Test	8-30
HP-IB Verification Test	8-32
Performance Test Record	8-35
Verification Test Record	8-40
9. Adjustment Procedures	
Safety Considerations	9-1
Introduction	9-1
Power Supply & Preliminary Adjustments	9-3
Overshoot & Transition Time Adjustment	9-6
Voltage Controlled Oscillator Adjustment	9-8
Width Adjustment	9-11
Shaper Adjustments	9-13
Offset Adjustment	9-18
Amplitude Modulator Adjustment	9-18

10. Introduction to Servicing	
Safety Considerations	10-1
Safety Check	10-1
General	10-3
10.1. Instrument Overview and Troubleshooting Guide	
Theory of Operation	10.1-1
Troubleshooting	10.1-3
Preparing the HP 8116A for servicing	10.1-3
E01	10.1-5
E11	10.1-5
E21	10.1-5
E31	10.1-5
E41	10.1-7
E42	10.1-7
E51	10.1-7
E52	10.1-7
E53	10.1-7
E54	10.1-7
E55	10.1-9
E56	10.1-9
E57	10.1-9
E58	10.1-9
E59	10.1-11
E60	10.1-11
E61	10.1-11
E62	10.1-11
10.2. Servicing the Power Supply	
Theory of Operation	10.2-1
Introduction	10.2-1
Line Voltage Selector and Transformer	10.2-1
Bridge Rectifiers and Regulators	10.2-2
Voltage and Current Sensing Circuits	10.2-2
Power-down Detection	10.2-3
Troubleshooting the Power Supply	10.2-9
Removing the fan	10.2-9
Re-fitting the fan	10.2-9
±24 V supplies	10.2-10
10.3. Servicing the VCO and Width Generator	
Theory of Operation	10.3-1
Introduction	10.3-1
Trigger Input Circuits	10.3-1
Control Input Circuits	10.3-2
VCO (Slope) IC	10.3-3
Timing IC	10.3-5
Troubleshooting	10.3-13
Trigger-level Circuit and Amplifier	10.3-13
Control Mode Selection	10.3-13
Frequency Range Selection	10.3-14

Waveform Selection	10.3-14
VCO	10.3-14
Width Generator	10.3-16
10.4. Servicing the Shaper and Output Amplifier	
Theory of Operation	10.4-1
Introduction	10.4-1
Shaper IC	10.4-1
Amplitude Modulator	10.4-2
Current Mirror	10.4-2
Pre-Attenuator	10.4-3
Signal Output Amplifier	10.4-3
Output Attenuator	10.4-5
Trigger Output Amplifier	10.4-5
Troubleshooting	10.4-11
Shaper IC Inputs	10.4-11
Shaper IC Amplitude-vernier Control-voltage	10.4-12
Shaper IC Reference Current	10.4-12
Shaper IC Current-mirror	10.4-13
Pre-Attenuator and Output Attenuator Control Signals	10.4-13
Offset-vernier Control-voltage	10.4-13
Output Amplifier	10.4-13
10.5. Servicing the Standard Control Board	
Theory of Operation	10.5-1
Introduction	10.5-1
Timer	10.5-1
Address Decoders	10.5-1
-9 V Reference Circuit	10.5-1
Digital to Analog Converters	10.5-2
Offset and Amplitude circuits	10.5-3
Width Vernier Current Source	10.5-3
Up and Down Current Sources	10.5-4
Capacitance Amplifier	10.5-4
Troubleshooting	10.5-13
Timer	10.5-13
Address Decoders	10.5-13
Frequency Control	10.5-14
Duty Cycle Control	10.5-14
Width Control	10.5-14
Amplitude Control	10.5-15
Offset Control	10.5-15
Capacitance Amplifier	10.5-16

10.6. Servicing the Option 001 Control Board	
Theory of Operation	10.6-1
Introduction	10.6-1
Burst Number Acceptors	10.6-1
Counter	10.6-2
Blocking Flip-flop	10.6-2
X-Output Generator	10.6-2
Marker Output	10.6-2
Hold Input	10.6-2
Troubleshooting	10.6-7
Output Address Decoder	10.6-7
Burst Counter	10.6-7
10.7. Servicing the Microprocessor and Frontpanel	
Theory of Operation	10.7-1
Introduction	10.7-1
Read Only Memory (ROM)	10.7-2
Random Access Memory (RAM)	10.7-2
RAM Battery Supply	10.7-2
HP-IB General Purpose Interface Adapter	10.7-2
Address Decoding	10.7-4
Control Board Address Decoding	10.7-5
Key Scanning	10.7-5
Display Driving	10.7-5
Reset Circuits	10.7-6
Troubleshooting	10.7-17
Free Running Signature Analysis	10.7-17
Address Bus	10.7-17
ROM	10.7-18
Changing the ROM	10.7-19
Keyboard	10.7-19
A. Replaceable Parts	
Introduction	A-1
General	A-1
Ordering Parts	A-1
Standard Instrument Parts-lists	A-5
Master List	A-5
Main Board	A-7
Control Board	A-27
Microprocessor Board	A-32
Keyboard	A-36
Display Board	A-38
Option 001 Parts-lists	A-40
Master List Option 001	A-40
Control Board Opt 001	A-41
Keyboard Opt 001	A-48
Display Board Opt 001	A-51

B. Backdating	
C. Updating	
Introduction	C-1
D. Sales and Service Offices	
Index	

Figures

1-1. Serial Number Plate (FRG)	1-1
3-1. Line Voltage Selector Switches	3-2
3-2. Power Cables & Plug Identification	3-3
3-3. HB-IB Connector	3-5
4-1. HP 8116A Front Panel	4-2
4-2. Trigger Mode Controls	4-4
4-3. External Trigger Controls	4-6
4-4. Control mode controls	4-7
4-5. Trigger & Control mode combinations	4-7
4-6. Amplitude Modulation	4-8
4-7. Pulse Width Modulation characteristics	4-9
4-8. VCO characteristics	4-10
4-9. Waveform controls	4-11
4-10. Parameter controls	4-12
4-11. Timing parameters	4-13
4-12. Level parameters	4-13
4-13. Output controls	4-15
4-14. Rear panel	4-16
5-1. Typical outputs in Normal mode	5-2
5-2. Typical signals in Trigger mode	5-3
5-3. Typical signals in Gate mode	5-5
5-4. Typical signals in External Width mode	5-6
5-5. Sweep Mode Signals	5-8
5-6. Typical outputs in Internal Burst mode	5-9
5-7. Typical signals in External Burst mode	5-9
8-1. Frequency Performance Test	8-2
8-2. Duty Cycle Performance Test	8-4
8-3. Pulse Width Performance Test - Stage 1	8-6
8-4. Pulse Width Performance Test - Stage 2	8-6
8-5. Amplitude & Offset Performance Test	8-8
8-6. Sine Waveform Performance Test	8-10
8-7. Typical Spectrum Analyzer display at 1 kHz.	8-11
8-8. Typical Spectrum Analyzer display at 50 MHz.	8-12
8-9. Pulse/Squarewave Performance Test	8-14
8-10. DC Output Performance Test	8-16
8-11. Trigger, Gate & External Width Performance Test	8-18
8-12. Burst Modes Verification Test	8-20
8-13. Frequency Modulation Verification Test	8-22
8-14. Amplitude Modulation Verification Test	8-24
8-15. Pulse Width Modulation Verification Test	8-26
8-16. Sweep Mode Verification Test	8-28
8-17. Autovernier & Output Mode Verification Test	8-30

8-18. HP-IB Verification Test	8-32
9-1. HF symmetry adjustment	9-10
9-2. Low Pass Filter	9-14
9-3. Typical Spectrum During 2nd Harmonic Adjustment	9-15
9-4. Amplitude Modulator Adjustment - Equipment Set-up.	9-18
9-5. Amplitude Modulation Spectrum	9-19
9-6. 100% Amplitude Modulation with Correct Offset	9-21
9-7. 100% Amplitude Modulation with Incorrect Offset	9-21
9-8. Adjustment Points on the Main Board A1	9-22
9-9. Adjustment Points on the Control Board A2	9-23
10.1-1. HP 8116A Functional block diagram	10.1-1
10.1-2. Custom ICs used in the HP 8116A	10.1-2
10.1-3. HP 8116A in its servicing position	10.1-3
10.2-1. Power Supply block diagram	10.2-1
10.2-2. Main Board A1 - Schematic 1	10.2-5
10.2-3. Main Board A1 - Schematic 2	10.2-7
10.2-4. Detail of wiring to Line Voltage Selector switches	10.2-9
10.2-5. Power supply components - Underside of main board A1	10.2-11
10.3-1. Simplified Trigger-level circuit	10.3-1
10.3-2. VCO IC block diagram	10.3-3
10.3-3. The relationship between startphase and triggering signal	10.3-4
10.3-4. Timing IC block diagram	10.3-5
10.3-5. Main Board A1 - Schematic 3	10.3-7
10.3-6. Main Board A1 - Schematic 4	10.3-9
10.3-7. Main Board A1 - Schematic 5	10.3-11
10.3-8. Trigger Input Amplifier signals	10.3-13
10.3-9. VCO Input and Output signals	10.3-15
10.3-10. Width Generator Input and Output signals	10.3-17
10.4-1. Shaper IC Block Diagram	10.4-1
10.4-2. Current Mirror	10.4-3
10.4-3. Simplified Output Amplifier circuit	10.4-4
10.4-4. Main Board A1 - Schematic 6	10.4-7
10.4-5. Main Board A1 - Schematic 7	10.4-9
10.4-6. Shaper IC Input and Output (Sine/Triangle)	10.4-11
10.4-7. Shaper IC Input and Output (Square/Pulse)	10.4-12
10.4-8. Main Board A1 - Component layout	10.4-15
10.4-9. Main Board A1 - Component locator	10.4-17
10.5-1. Principle of DAC Operation	10.5-2
10.5-2. DAC - Reciprocal operation	10.5-2
10.5-3. Ramp generation by charging and discharging a capacitor with constant currents	10.5-4
10.5-4. Simplified Capacitance Amplifier	10.5-5
10.5-5. Standard Control Board A2 - Schematic 1	10.5-7
10.5-6. Standard Control Board A2 - Schematic 2	10.5-9
10.5-7. Standard Control Board A2 - Schematic 3	10.5-11
10.5-8. Standard Control Board A2 - Component layout and locator	10.5-17
10.6-1. Simplified Burst Generator (Option 001)	10.6-1
10.6-2. X-output in sweep mode	10.6-2
10.6-3. Option 001 - Schematic 1	10.6-3
10.6-4. Option 001 - Schematic 2	10.6-5
10.6-5. Burst-counter waveform and timing data	10.6-8

10.6-6. Option 001 Control Board A2 - Component layout and locator	10.6-9
10.7-1. Microprocessor board architecture	10.7-1
10.7-2. GPIA IC pins	10.7-3
10.7-3. Address decoding	10.7-4
10.7-4. Microprocessor Board A3 - Schematic 1	10.7-7
10.7-5. Microprocessor Board A3 - Schematic 2	10.7-9
10.7-6. Microprocessor Board A3 - Schematic 3	10.7-11
10.7-7. Keyboard A4 and Display Board A5 - Schematic	10.7-13
10.7-8. Keyboard A4 and Display Board A5 - Schematic (Option 001)	10.7-15
10.7-9. Microprocessor Board A3 - Component layout and locator	10.7-21
10.7-10. Keyboard A4 and Display Board A5 - Component layouts and locators . .	10.7-23
10.7-11. Keyboard A4 and Display Board A5 - Component layouts and locators (Option 001)	10.7-25
A-1. Mechanical Parts - 1	A-2
A-2. Mechanical Parts - 2	A-3

Tables

1-1. Recommended Test Equipment	1-4
1-2. Recommended Test Accessories	1-4
3-1. Line Voltage and Fuse Selection	3-2
5-1.	5-8
6-1.	6-12
9-1. Adjustment Procedures - Changeable Components	9-2
10-1. HP 8116A Board Assemblies & Servicing Chapters	10-4
10.2-1. Power supply rectifiers	10.2-2
10.2-2. Regulated voltage supplies	10.2-2
10.3-1. Control signal output from U152	10.3-2
10.3-2. U201 Startphase control	10.3-3
10.3-3. U205 Control Signals	10.3-4
10.3-4. U300 Digital Control Signals	10.3-5
10.3-5. Timing IC Range Selection	10.3-6
10.3-6. U150 Control Mode truth table	10.3-13
10.3-7. U210 Frequency Range truth table	10.3-14
10.3-8. U103 Waveform truth table	10.3-14
10.3-9. U205 truth table	10.3-15
10.3-10. I_{up} , $I_{up\ ref}$ and $I_{down\ ref}$ currents at 50% duty-cycle	10.3-16
10.3-11. Voltage at R308/C303	10.3-17
10.4-1. Pre-attenuator ranges	10.4-3
10.4-2. Amplitude-vernier Control-voltages	10.4-12
10.4-3. Attenuator Control truth table	10.4-13
10.4-4. Offset-vernier Control-voltages	10.4-13
10.5-1. Signatures for Control Board Address Decoders	10.5-13
10.5-2. U16 Frequency Range Selection	10.5-14
10.5-3. Frequency DAC - Output Voltages	10.5-14
10.5-4. Duty-Cycle DACs - Output Voltages	10.5-14
10.5-5. Width Vernier DAC - Output Voltages	10.5-14
10.5-6. U17 Width Range Selection	10.5-15
10.5-7. Amplitude DAC - Output Voltages	10.5-15
10.5-8. U17 Amplitude Range Selection	10.5-15
10.5-9. Offset DAC - Output Voltages	10.5-16
10.5-10. U17 Offset Range Selection	10.5-16
10.5-11. U3 Capacitance Amplifier Range Selection	10.5-16
10.6-1.	10.6-7
10.7-1. Display Driver Control Signals	10.7-5
10.7-2. Signature Analyzer Probe connections	10.7-17
10.7-3. Signatures for Address Drivers and Decoders	10.7-18
10.7-4. Signature Analyzer Probe connections for ROM Test	10.7-18
10.7-5. ROM U40 signatures	10.7-19
10.7-6. Keyboard signatures	10.7-20
A-1. Key to HP Manufacturer References	A-4

A-2. Standard HP 8116A Parts List	A-5
A-3. Standard HP 8116A Main Board Parts List	A-7
A-4. Standard HP 8116A Control Board Parts List	A-27
A-5. Standard HP 8116A Microprocessor Board Parts List	A-32
A-6. Standard HP 8116A Keyboard Parts List	A-36
A-7. Standard HP 8116A Display Board Parts List	A-38
A-8. Option 001 HP 8116A Master Parts List	A-40
A-9. Option 001 HP 8116A Control Board Parts List	A-41
A-10. Option 001 HP 8116A Keyboard Parts List	A-48
A-11. Option 001 HP 8116A Display Board Parts List	A-51

Introduction

General

This manual describes the following procedures for the HP 8116A 50 MHz Programmable Pulse/Function Generator:

- Installation
- Operating
- Programming
- Testing Performance
- Adjustment
- Servicing

A Microfiche version of this manual is available on 4×6 inch microfilm transparencies (refer to title page for order number). The microfiche package also includes the latest Manual Changes supplement and all relevant Service Notes.

Instruments Covered by This Manual

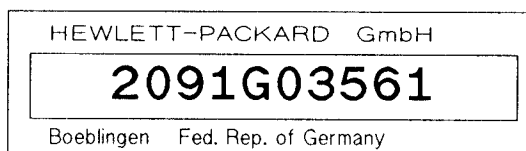

Figure 1-1. Serial Number Plate (FRG)

Attached to the rear of the instrument is a serial number plate (Figure 1-1). The first four digits only change when there is a significant modification to the instrument, the last five digits are assigned to instruments sequentially. This manual applies directly to the instrument with the serial number quoted on the title page. For instruments with higher serial numbers, refer to the Manual Change sheets in Appendix C. To keep this manual up-to-date, Hewlett-Packard recommends that you periodically request the latest Manual Change supplement by quoting the part-number and print-date of this manual, both of which appear on the title page.

Instrument Description

The HP 8116A Programmable Pulse/Function Generator operates over the frequency range 1 mHz to 50MHz and is capable of driving a 16 V peak-to-peak amplitude output signal into a 50 Ω load. Capabilities include:

- Multi-waveform generation:
 - Sine
 - Square
 - Triangle
 - Pulse
- 7 ns transition time for pulse and squarewave.
- Variable pulse width down to 10 ns.
- AM/FM/PWM modulation modes.
- VCO control mode.
- HP-IB programmable.
- Internal and external logarithmic sweep (Option 001).
- Internal and external burst mode for all waveforms (Option 001).

The self-prompting operation and HP-IB programmability of the HP 8116A ensure that it is quick and easy to use in stand-alone and automatic-test applications.

Note



Throughout this manual, instrument keys are shown as Key in the text. “Key” is the key name which appears above the key on the instrument front panel.

HP 8116A Options

Option 001

Option 001 provides the HP 8116A with increased capabilities including:

- Logarithmic sweep (selectable internal or external triggering).
- Counted burst (selectable internal or external triggering).
- Hold input for sine, triangle and squarewave.

Note



Option 001 is not retrofittable, it is only available when ordering a new instrument.

Accessories

Included The HP 8116A is supplied complete with the following:

Item	HP Part Number
750 mA fuse for 220/240 V operation	2110-0813
or	
1.5 A fuse for 100/120 V operation	2110-0043
and	
Power cable	See Figure 3-2

Available The following accessories are available for the HP 8116A:

Item	HP Part Number
Carrying handle (Bail Handle Kit)	5062-4001
Rack mounting flange and filler panel for rack mounting a single HP 8116A	5062-3972
Rack mounting flange and Lock link kit for rack mounting two HP 8116As	5062-3974 5061-0094

Recommended Test Equipment

The recommended test equipment and accessories required to maintain the HP 8116A are listed in Table 1-1 and Table 1-2. Alternative equipment can be substituted provided that it meets or exceeds the critical specifications given in the tables.

Table 1-1. Recommended Test Equipment

Instrument	Recommended Model	Required Characteristics	Alternative	Use*
Counter	HP 5358A	50 MHz, Start/Stop, TI, A to B	HP5345A and HP 5363B	P, A
Digital Voltmeter	HP 3456A	DC .1 V-10 V, .004% acc.		P, A
Digital Multimeter	HP 3466A	AC .1 V-10 V, DC .1 mA-10 mA		P, A, T
Function Generator	HP 3325A	20 MHz, THD \leq .1%	HP3324A	P, A
Pulse Generator	HP 8112A	Pulse width 50 μ s - 500 ms		P
Digitizing Scope	HP 54121T	1 GHz	HP 54503A	P, A
Attenuators	HP 33340C	20 dB, 2 W		P, A, T
Spectrum Analyzer	HP 8568B	100 Hz to 350 MHz		P, A
Signature Analyzer	HP 5005B			T

Table 1-2. Recommended Test Accessories

Accessory	Recommended Model	Required characteristics	Alternative	Use*
Attenuator	HP 33340C	20 dB		P, A
Logic Probe	HP 545A	TTL		T
Terminators	HP 11048C HP10100C	1 W, 50 Ω , \pm 0.1 Ω 2 W, 50 Ω		P, A T

* P = Performance Test; A = Adjustments; T = Troubleshooting

Specifications

Introduction

All specifications in the following sections describe the instrument's warranted performance:

- Timing parameters
- Output parameters
- Waveform characteristics

All specifications apply with a $50\ \Omega$ load, after a 30 minute warm-up period, and are valid for ambient temperature in the range 15°C to 35°C . Refer to the General Characteristics section of this chapter for the performance derating factor to be used outside this temperature range (within the specified operating range of 0°C to 55°C).

All operating characteristics given in the following sections describe typical performance figures which are non-warranted:

- Trigger modes
- Control modes
- Inputs and Outputs
- Additional features
- General characteristics

Timing Parameters

Unless otherwise stated, specifications are quoted for 50% amplitude in normal mode.

Frequency

Range

1.00 mHz to 50.0 MHz

Resolution

3 digits, best case 10 μ Hz (0.01 mHz)

Stability

$\pm 0.2\%$ (1 hour)

$\pm 0.5\%$ (24 hours)

Repeatability

Factor 4 better than accuracy

Accuracy

Frequency (FRQ)	Pulse mode or waveforms with 50% duty cycle	Waveforms with duty cycle \neq 50%
$1 \text{ mHz} \leq \text{FRQ} < 100 \text{ kHz}$	$\pm 3\% \pm 0.3 \text{ mHz}$	$\pm 3\% \pm 0.6 \text{ mHz}$
$100 \text{ kHz} \leq \text{FRQ} < 10 \text{ MHz}$	$\pm 5\%$	$\pm 10\%$
$10 \text{ MHz} \leq \text{FRQ} \leq 50 \text{ MHz}$	$\pm 5\%$	n/a
Jitter	$< 0.1\% + 100 \text{ ps}$	$< 0.2\% + 100 \text{ ps}$
RMS Jitter	$0.03\% + 30 \text{ ps}$	$0.06\% + 30 \text{ ps}$

Duty Cycle

Frequency (FRQ)	Range and Resolution	Accuracy
$1 \text{ mHz} \leq \text{FRQ} < 1 \text{ MHz}$	10% to 90% in steps of 1%	$\pm 0.5 \text{ LSD}^*$
$1 \text{ MHz} \leq \text{FRQ} < 10 \text{ MHz}$	20% to 80% in steps of 1%	$\pm 3.0 \text{ LSD}$
$10 \text{ MHz} \leq \text{FRQ} \leq 50 \text{ MHz}$	50% fixed	$\pm 5.0 \text{ LSD, typical}$

*Least Significant Digit (only units and tens are displayed)

Pulse Width

Range

10.0 ns to 999 ms
(Maximum = $1/\text{FRQ} - 10 \text{ ns}$)

Resolution

3 digits, best case 100 ps (0.1 ns)

Accuracy

$\pm 5\% \pm 2 \text{ ns}$

Repeatability

Factor 4 better than accuracy

Jitter

0.2% + 200 ps (width $\leq 10 \mu\text{s}$)
0.1% (width $> 10 \mu\text{s}$)

RMS Jitter

0.06% + 60 ps (width $\leq 10 \mu\text{s}$)
0.03% + 30 ps (width $> 10 \mu\text{s}$)

Output Parameters

Note



Output voltages are specified for a 50 Ω load. Output voltages double when driving a high impedance load.

Output Impedance 50 Ω ± 2.5 Ω

Amplitude/Offset Amplitude and offset are independently variable within the following two level windows:

Level window:	±800 mV	±8.00 V
Amplitude range	10.0 mV to 99.9 mV (p-p)	100 mV to 16.0 V (p-p)
Amplitude resolution	3 digits (best case 0.1 mV)	3 digits (best case 1 mV)
Amplitude accuracy*	± 5%	± 5%
Offset range	0 to ±795 mV	0 to ±7.95 V
Offset resolution	3 digits (best case 0.1 mV)	3 digits (best case 1 mV)
Offset accuracy	±1% of programmed value ±1% of amplitude ±4 mV	±0.5% of programmed value ±1% of amplitude ±40 mV
Repeatability	Factor 4 better than accuracy	

* The amplitude accuracy for sine and triangle is specified at 1 kHz. The following table specifies the amplitude flatness at other frequencies for an output signal with 50% duty cycle:

Amplitude Flatness

Frequency (FRQ)	Sine	Triangle
1 mHz ≤ FRQ < 1 MHz	±3%	±3%
1 MHz ≤ FRQ < 10 MHz	±5%	±5%
10 MHz ≤ FRQ ≤ 50 MHz	+5%, -15%	+5%, -25%

Waveform Characteristics

Sine The following specifications apply for normal output mode and 50% duty cycle.

Total Harmonic Distortion (THD) < 1% (-40 dB), (10 Hz to 50 kHz).
This may increase by 3 dB below 10°C.

Harmonic signals < 2% (-34 dBc*)
for 50 kHz ≤ FRQ < 1 MHz

< 7% (-23 dBc*)
for FRQ ≥ 1 MHz
and amplitude < 8 V (p-p)

* dBc = dB relative to carrier (fundamental).

Triangle

Linearity < ±3% (10% to 90% of amplitude
and 100 mHz ≤ FRQ < 1 MHz)

Square, Pulse

Transition time < 7 ns (10% to 90% of amplitude)

Pulse perturbations < ±5% of amplitude ±2 mV

Settling time 100 ns + transition time

DC Output A dc output voltage is generated when all waveform selection keys are deactivated.

Range 0 mV to ±7.95 V

Resolution 3 digits, best case 1mV

Accuracy ±0.5% ±40 mV

Repeatability Factor 4 better than accuracy

Operating Characteristics

The following sections give non-warranted information on the instrument's typical operating characteristics:

- Trigger modes
- Control modes
- Inputs and Outputs
- Additional features
- General characteristics

Trigger Modes

The external trigger signal referred to in this section is applied to the **EXT INPUT** BNC connector on the instrument front panel. The trigger level and sense are adjustable. An external trigger can be simulated by pressing the **(MAN)** key.

The period and duty cycle of the first output cycle may deviate up to 10% from subsequent cycles.

Note



* indicates that in this mode the startphase of sine and triangle waveforms is selectable between 0° and -90° using the **(-90°)** key.

Normal

A continuous output waveform is generated.

In Normal mode, all parameters can be automatically incremented or decremented with selectable resolution. Pressing the **(AUTO)** key enables this **AUTO** vernier, which can then be started by pressing the required vernier key. The **AUTO** vernier is stopped by an external trigger input or by pressing the **(AUTO)** key again.

*Trigger

Each active input edge triggers a single output cycle.

*Gate

The active level of the external signal enables output cycles. The first output cycle is synchronous with the active trigger slope. The last output cycle is always completed. The **(MAN)** key can be used to simulate an external gate signal.

External Width

In pulse waveform mode only, the external signal is shaped to determine output pulse width. This mode can be used for pulse recovery. The amplitude and offset controls are active.

**Logarithmic Sweep
(Option 001)**

For all waveforms the output signal frequency performs a logarithmic sweep between selected start and stop frequencies within the instrument's range (1 mHz to 50 MHz). The sweep time per decade is selectable between 10 ms and 500 s but restricted to intervals in the ratios 1:2:5. The sweep always starts with 0° output phase.

Internal sweep Continuous sweep cycles.

External sweep One sweep cycle is triggered by the external signal.

Marker frequency Programmable, see Marker Output.

Sweep ramp voltage See X-Output.

***Counted Burst
(Option 001)**

The HP 8116A generates a preprogrammed number (1 to 1999) of output cycles. The maximum burst frequency in this mode is 40 MHz.

Internal burst: Output bursts are repeatedly generated at programmable time intervals in the range 100 ns to 999 ms. This mode is not available in pulse waveform mode.

External burst: An output burst is triggered by the external signal. The minimum time between burst triggers is 100 ns.

The **1 CYCLE** key can be used to initiate a single output cycle.

Control Modes

An external control signal applied to the **CTRL INPUT** BNC connector can be used to modulate the output signal.

Frequency Modulation

Deviation $\pm 5\%$ maximum for ± 6 V input
Modulation bandwidth dc to 20 kHz (FRQ < 10 MHz)
dc to 3 kHz (FRQ \geq 10 MHz)

Amplitude Modulation

Modulation 100% with ± 2.5 V input
DSBSC (Double Side Band Suppressed Carrier) with +2.5 V, -7.5 V input
Modulation bandwidth dc to 1 MHz
Envelope distortion < 1% for modulation depth < 90%
(dc to 50 kHz and not complementary output)

Pulse Width Modulation

Modulation range Maximum of one decade with ± 6.5 V input
Pulse width ranges 10 ns to 1 s in eight adjacent decade ranges

Voltage Controlled Oscillator

The external voltage signal linearly sweeps the output frequency through two complete decades.

Modulation range Maximum of two decades with 0.1 V to 10 V input.
11 overlapping ranges from 1 mHz to 50 MHz with 2 decades per range.
Display shows the maximum frequency in the current range.

Modulation bandwidth dc to 1 kHz

Output modes

Complement	Selectable on/off
Disable	Disconnects output, default on switching on.
Limit	Implements present output levels as output limits.
Hold (Option 001)	External hold signal freezes output at current level. This mode only applies at frequencies < 10 Hz. In hold mode the output droop is < 0.01% of the amplitude per second.

Inputs and Outputs

External Input	Threshold level	± 10 V adjustable
	Trigger slope	Positive or negative or trigger off
	Minimum amplitude	500 mV (p-p)
	Input voltage limits	± 20 V
	Minimum pulse width	10 ns
	Input impedance	10 k Ω
Control Input	Input voltage limits	± 20 V
	Input impedance	10 k Ω
Hold Input (Option 001)	Hold level	> 2.5 V, or open circuit
	Run level	< 2.5 V
	Input voltage limits	± 20 V
	Input impedance	10 k Ω
Main Output	Range	± 8 V into 50 Ω
	Output Impedance	50 $\Omega \pm 2.5 \Omega$
	External voltage limits	Do not apply external voltage
	Short circuit capability	Maximum peak current 320 mA for up to 1 hour (15°C to 35°C)
Trigger Output	High level	2.4 V into 50 Ω
	Low level	0 V
	Active edge	Positive
	Output impedance	50 Ω
	Propagation Delay	60 ns (EXT INPUT to TRIG OUTPUT)
	External voltage limits	0 V, +5 V
	Duty cycle	Dependant on main output signal

Marker Output (Option 001)	High level	2.4 V into 50 Ω	
	Low level	0 V	
	Edges		Positive at marker frequency
			Negative at start of sweep
	Output impedance	50 Ω	
	External voltage limits	0 V, +5 V	
X-Output (Option 001)	Levels	0 V to 10 V, 1.5 V per sweep decade into high impedance.	
	Output impedance	1 k Ω	
	External voltage limits	0 V, +5 V	

Additional Features

HP-IB Capability The HP 8116A is fully programmable except for the External Input trigger level.

Capability codes

SH1, AH1, T6, L4, SR1, RL1, PP0, DC1, DT1

Learn mode

All or individual parameters can be programmed

Learn string

Total 89 characters (161 characters with Option 001).

Message Interpretation times

Modes	30 ms
Timing parameters	50 ms
Voltages	250 ms

Execution times

5 ms (Offset 30 ms)

Transmission times

Status	15 ms
Learn string	1 ms per character

Self-test The instrument performs a self-test when switched on, and by HP-IB command.

Memory The current settings are stored when the instrument is switched off.

Error detection The instruments indicates incompatible settings on the front panel and via the status byte.

General Characteristics

Environmental	Storage temperature range	-40°C to 70°C
	Operating temperature range	0°C to 55°C
	*Specification temperature range	15°C to 35°C
	Humidity range	Up to 95% R.H., 0°C to 40°C
* The accuracy specification derating factor for temperatures outside this range is $1 + 0.05 \times d^{\circ}\text{C}$ where $d^{\circ}\text{C}$ is the temperature deviation below 15°C or above 35°C.		
Power supply	<ul style="list-style-type: none">■ 100/120/220/240 V rms (selectable) +5%, -10%■ 48-440Hz■ 120 VA maximum	
Weight	Net	5.9 kg (13 lbs)
	Shipping	11.0 kg (24.4 lbs)
Dimensions	<ul style="list-style-type: none">■ 89 mm high (3.5 in)■ 213 mm wide (8.4 in)■ 450 mm deep (17.7 in)	
Recalibration period	1 year recommended	

Installation

Introduction

This chapter provides installation instructions for the HP 8116A. It also includes information about initial inspection and damage claims, preparation for use, packaging, storage and shipment.

Safety Considerations

The HP 8116A is a Safety Class 1 instrument (instrument with an exposed metal chassis that is directly connected to earth via the power supply cable).

Before operation review the instrument and manual, including the red safety page, for safety markings and instructions. These must then be followed to ensure safe operation and to maintain the instrument in safe condition.

Initial Inspection

Inspect the shipping container for damage. If the container or cushioning material is damaged, keep it until the contents of the shipment have been checked for completeness and the instrument has been verified both mechanically and electrically.

Warning



To avoid hazardous electric shock, do not perform electrical tests when there are signs of shipping damage to any part of the instrument's outer covers or panels.

Procedures for testing the instrument's performance are given in Chapter 8. Information for connecting the instrument to the local power supply is given in the next section of this chapter.

If the contents are incomplete, or there is mechanical damage, or if the instrument does not pass the Performance Tests, notify the nearest Hewlett-Packard office. Keep the shipping materials for inspection by the carrier. The HP office will arrange for repair or replacement without awaiting settlement.

Power Requirements and Line Voltage Selection



Caution



BEFORE APPLYING AC LINE POWER TO THE HP 8116A, ensure that the instrument is set to the local line voltage and the correct line fuse is installed in the fuse holder.

The instrument requires a power source of 100, 120, 220 or 240 V rms (+5%, -10%) at a frequency of 48-440 Hz single phase. The maximum power consumption is 120 VA.

The line voltage selector switches can be seen through the lefthand side of the instrument's case towards the rear. The line voltage selector is set at the factory to the most commonly used line voltage for the country of destination. The instrument power fuse is located on the rear panel.

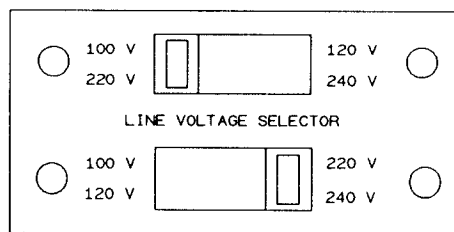

Figure 3-1. Line Voltage Selector Switches

Caution



Do not change the Line Voltage Selector switch settings with the instrument switched on or with power connected via the rear panel.

To change the selected line voltage:

1. Remove the power cord.
2. Using a screwdriver which is small enough to fit through the ventilation holes, move each switch to the side showing the local supply voltage. If you do not have a small enough screwdriver, remove the instrument cover as described in "Preparing the HP 8116A for servicing" in Chapter 10.1. This gives you complete access to the switches.
3. Fit the correct power fuse for the selected operating voltage.

Table 3-1. Line Voltage and Fuse Selection

Line Voltage	Fuse Type	HP Part Number
100 V / 120 V	1.5 A	2110-0043
220 V / 240 V	750 mA	2110-0813

Power Cable

Warning



To avoid the possibility of injury or death, the following precautions must be followed before the instrument is switched on:

- If the instrument is to be energised via an autotransformer for voltage reduction, ensure that the Common terminal is connected to the grounded pole of the power source
- The power cable must only be inserted into a socket outlet provided with a protective ground contact. The protective action must not be negated by the use of an extension cord without a protective conductor.
- Before switching on the instrument, the protective ground terminal of the instrument must be connected to the protective conductor of the power cable. This is verified by using the power cord which is supplied with the instrument.
- Intentional interruption of the protective ground connection is prohibited.

In accordance with international safety standards, the HP 8116A is equipped with a three-wire power cable. When connected to an appropriate ac power receptacle, this cable grounds the instrument cabinet. The type of cable shipped with each instrument depends on the country of destination. Refer to Figure 3-2 for the part numbers of the available cables.

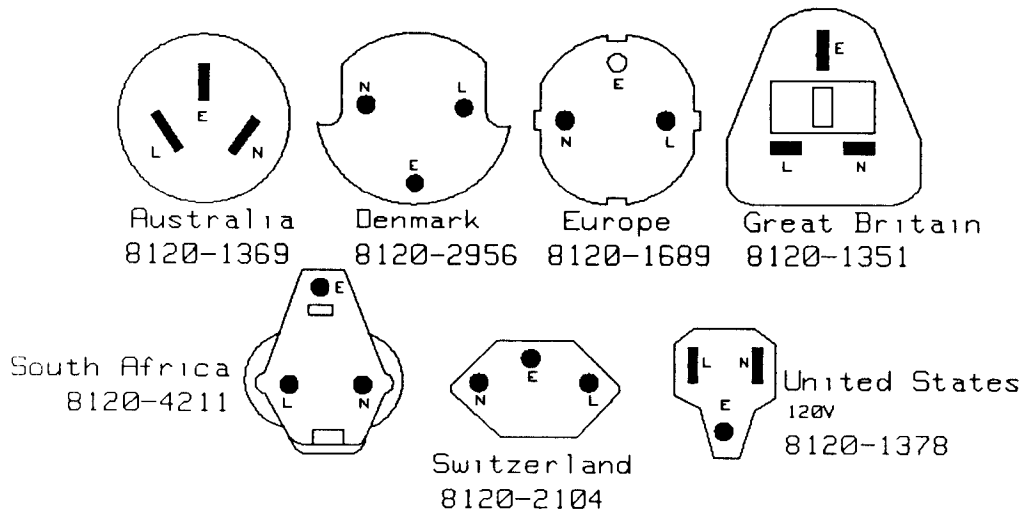

Figure 3-2. Power Cables & Plug Identification

The following work should be carried out by a qualified electrician - all local electrical codes being strictly observed. If the plug on the cable does not fit the power outlet, or the cable is to be attached to a terminal block, cut the cable at the plug end and re-wire it.

The color coding used in the cable will depend on the cable supplied. If a new plug is to be connected, it should meet local safety requirements and include the following features:

- Adequate load-carrying capacity (see specifications in Chapter 2).
- Ground connection.
- Cable clamp.

HP-IB Connector

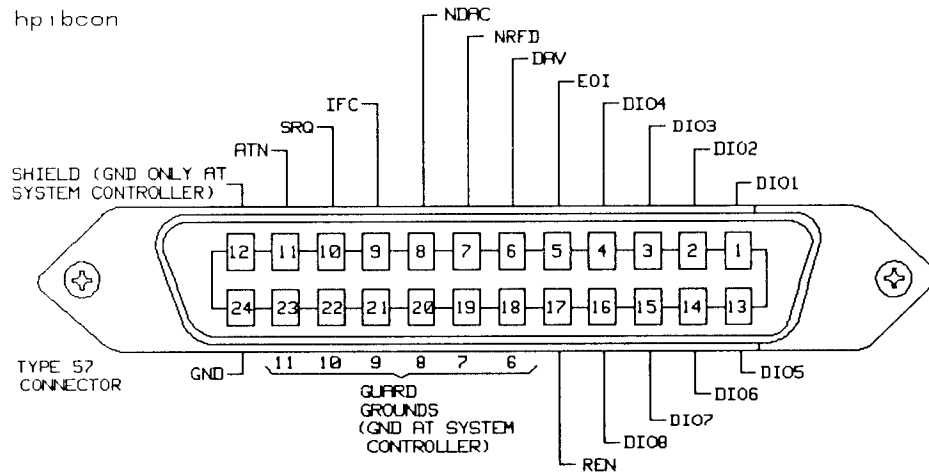

Figure 3-3. HB-IB Connector

The rear panel HP-IB connector (Figure 3-3), is compatible with the connector on Cable Assemblies 10833A, B, C and D. If a cable is to be locally manufactured, use male connector, HP part number 1251-0293.

HP-IB Logic Levels

The HP 8116A HP-IB lines use standard TTL logic, the levels being as follows:

- True = Low = digital ground or 0 Vdc to 0.4 Vdc,
- False = High = open or 2.5 Vdc to 5 Vdc.

All HP-IB lines have LOW assertion states. High states are held at 3.0 Vdc by pull-ups within the instrument. When a line functions as an input, approximately 3.2 mA of current is required to pull it low through a closure to digital ground. When a line functions as an output, it will sink up to 48 mA in the low state and approximately 0.6 mA in the high state.

Caution



The HP-IB line screens are not isolated from the instrument-chassis ground.

Operating Environment

Warning



The HP 8116A is not designed for outdoor use. To prevent potential fire or shock hazard, do not expose the HP 8116A to rain or other excessive moisture.

Temperature

The HP 8116A may be operated in temperatures from 0°C to 55°C.

Humidity

The HP 8116A may be operated in environments with humidity up to 95% (0°C to +40°C). However, the HP 8116A should be protected from temperatures or temperature changes which cause condensation within the instrument.

Instrument Cooling

The HP 8116A is equipped with a cooling fan mounted inside the rear panel. The instrument should be mounted so that air can freely circulate through it. When operating the HP 8116A, choose a location that provides at least 75 mm (3 inches) of clearance at the rear, and at least 25 mm (1 inch) of clearance at each side. Failure to provide adequate air clearance will result in excessive internal temperature, reducing instrument reliability.

Claims and Repackaging

If physical damage is evident or if the instrument does not meet specification when received, notify the carrier and the nearest Hewlett-Packard Service Office. The Sales/Service Office will arrange for repair or replacement of the unit without waiting for settlement of the claim against the carrier.

Storage and Shipment

The instrument can be stored or shipped at temperatures between -40°C and $+75^{\circ}\text{C}$. The instrument should be protected from temperature extremes which may cause condensation within it.

Return Shipment to HP

If the instrument is to be shipped to a Hewlett-Packard Sales/Service Office, attach a tag showing owner, return address, model number and full serial number and the type of service required.

The original shipping carton and packing material may be re-usable, but the Hewlett-Packard Sales/Service Office will also provide information and recommendations on materials to be used if the original packing is no longer available or reusable. General instructions for repacking are as follows:

1. Wrap instrument in heavy paper or plastic.
2. Use strong shipping container. A double wall carton made of 350-pound test material is adequate.
3. Use enough shock-absorbing material (3 to 4 inch layer) around all sides of the instrument to provide a firm cushion and prevent movement inside container. Protect control panel with cardboard.
4. Seal shipping container securely.
5. Mark shipping container FRAGILE to encourage careful handling.
6. In any correspondence, refer to instrument by model number and serial number.

HP 8116A 50 MHz Programmable Pulse/Function Generator

Operating and Programming Guide

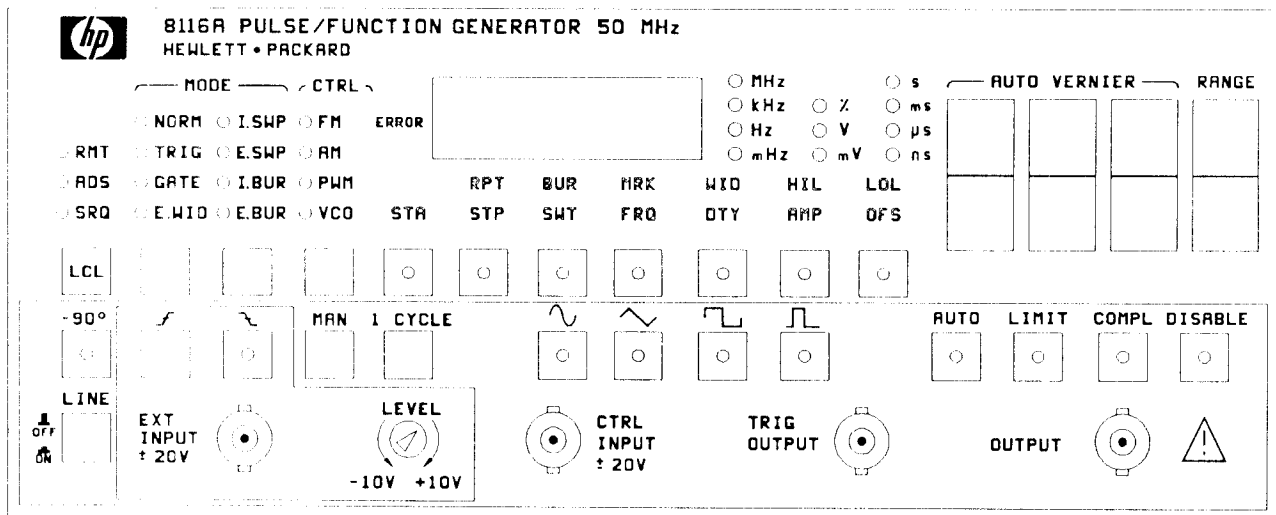

Printed in Federal Republic of Germany



Contents

4. Operating	
Introduction	4-1
Standard Parameter Set	4-3
Selecting Trigger Mode	4-4
Controlling the External Trigger	4-6
Selecting Control Mode	4-7
Selecting Output Waveform	4-11
Setting Parameters	4-12
Selecting Output Mode	4-15
Rear Panel	4-16
5. Operating Examples	
Introduction	5-1
Normal Mode	5-2
Trig Mode	5-3
Gate Mode	5-5
External Width Mode	5-6
Sweep Modes	5-7
Burst Modes	5-9
6. Programming	
General	6-1
HP-IB Addressing	6-1
Local, Remote and Local Lockout	6-2
Introduction	6-3
Selecting Trigger Modes	6-4
Selecting Control Modes	6-5
Setting Parameters	6-6
Autovernier	6-8
Reading parameters	6-9
Selecting Output Modes	6-10
Reading the Current Settings	6-11
Timing	6-12
Error, Fault and Status Reporting	6-13
HP-IB Status Byte	6-13
Timing Error (Bit 0)	6-14
Programming Error (Bit 1)	6-15
Syntax Error (Bit 2)	6-15
System Failure (Bit 3)	6-15
Autovernier in Progress (Bit 4)	6-16
Sweep in Progress (Bit 5)	6-16
Service Request (Bit 6)	6-16

Buffer not Empty (Bit 7)	6-16
HP-IB Universal Commands	6-17

7. Programming Examples

Introduction	7-1
Testing communication	7-2
Performing self-test	7-4
Using the Buffer Not Empty Flag	7-6
Using the Autovernier	7-8

Index

Figures

- 4-1. HP 8116A Front Panel 4-2
- 4-2. Trigger Mode Controls 4-4
- 4-3. External Trigger Controls 4-6
- 4-4. Control mode controls 4-7
- 4-5. Trigger & Control mode combinations 4-7
- 4-6. Amplitude Modulation 4-8
- 4-7. Pulse Width Modulation characteristics 4-9
- 4-8. VCO characteristics 4-10
- 4-9. Waveform controls 4-11
- 4-10. Parameter controls 4-12
- 4-11. Timing parameters 4-13
- 4-12. Level parameters 4-13
- 4-13. Output controls 4-15
- 4-14. Rear panel 4-16
- 4-15. HP-IB Address Switch (Factory setting) 4-16
- 5-1. Typical outputs in Normal mode 5-2
- 5-2. Typical signals in Trigger mode 5-3
- 5-3. Typical signals in Gate mode 5-5
- 5-4. Typical signals in External Width mode 5-6
- 5-5. Sweep Mode Signals 5-8
- 5-6. Typical outputs in Internal Burst mode 5-9
- 5-7. Typical signals in External Burst mode 5-9
- 6-1. HP-IB Address Switch (Factory setting) 6-1

Operating

Introduction

This chapter explains the use of all controls, indicators and connectors on the front and rear panels of the HP 8116A. Figure 4-1 and Figure 4-14 show the front and rear panel respectively. Each group of controls is explained in subsequent sections of this chapter under the following headings:

- Trigger Mode Selection
- External Trigger Controls
- Control Mode Selection
- Waveform Selection
- Parameter Selection
- Rear Panel

Examples are given in Chapter 5.

Before applying power to the HP 8116A:

1. Read the red Safety Summary sheet at the front of this manual.
2. Ensure the Line Voltage Selector switches are set properly for the power source to be used. Refer to Chapter 3 on instrument installation if necessary.

Caution



Do not change the Line Voltage Selector switches with the instrument switched on or with power connected to the rear panel.

3. Ensure that the device under test cannot be overdriven by the HP 8116A output (16 V p-p into 50 Ω ; 32 V p-p into high impedance).



Caution



Do not apply an external voltage or electrostatic discharge to the output connector.

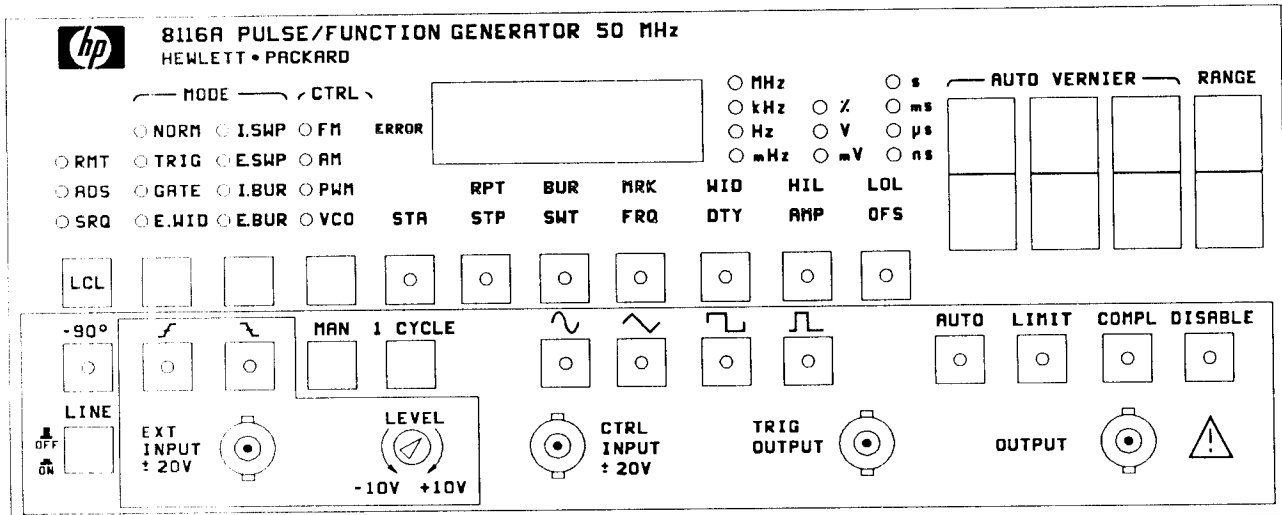

Figure 4-1. HP 8116A Front Panel

Switching On

The HP 8116A performs a “self test” when the power is switched on. All the frontpanel LEDs should light momentarily. If the frontpanel LEDs continue to flash, the instrument power supply is overloaded, refer to “±24 V supplies” in Chapter 10.2. If a fault is detected, an error code is displayed on the front panel digital display. The possible error codes are:

- A key is stuck in the depressed position.
- E11 There is a fault with the Auto Vernier/External Sweep trigger.
- E21 There is a fault in the internal repetition rate generator.
- E31 There is a fault in the internal width circuits. The width setting in pulse mode, and the time between bursts in internal burst mode are affected.
- E41/42 The output amplifier is faulty.
- E51-E62 Error indication for dedicated service tests.

Refer to Chapter 10.1 for more information on the error codes and their causes.

If the self-test is passed, the instrument automatically assumes the operating state which was active when last switched off, except that the output is disabled to protect the unit under test. If the instrument battery has failed, the Standard Parameter Set is selected.

Standard Parameter Set

The Standard Parameter Set exists for two reasons. Firstly, if the instrument RAM becomes corrupted due to battery failure, the Standard Parameter Set will be selected when the instrument is switched on, in order to give an error free display. Secondly, if an invalid combination of Operating and Control modes is selected, switching the instrument off and on again will revert to the Standard Parameter Set. The Standard Parameter Set is:

Trigger mode	Normal
Control mode	Off
Waveform	Sine
Frequency	1.00 kHz
Duty cycle	50%
High output level	0.5 V
Low output level	-0.5 V
Auto vernier	Off
Limit	Off
Complement	Off
Output Disable	On
Trigger	Off

If Option 001 is installed, Internal Sweep mode has the following standard parameters:

Start frequency	1.00 kHz
Stop frequency	100 kHz
Sweep time	50 ms
Marker frequency	1.00 kHz

If Option 001 is installed, Internal Burst mode has the following standard parameters:

Repeat time	100 ms
Burst length	1

Selecting Trigger Mode

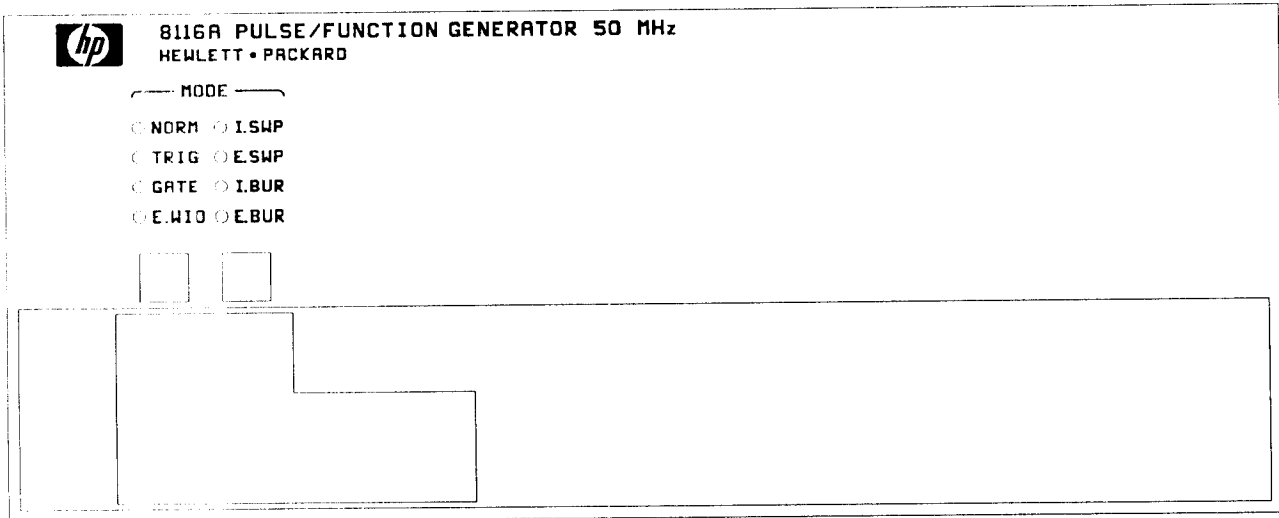

Figure 4-2. Trigger Mode Controls

Mode Selection

The currently active mode is shown by LED indicator. The trigger mode can be cycled through available options by pressing the key below the mode indicators.

The standard instrument offers the following trigger modes:

- | | |
|--------------|---|
| NORM | In normal mode a continuous output waveform is generated. |
| TRIG | In trigger mode each active input edge triggers a single output cycle. |
| GATE | In gate mode the active level of the external input signal enables output cycles. The first output cycle is synchronous with the active trigger slope. The last output cycle is always completed. |
| E.WID | In external width mode, which is only valid with pulse waveform, the external input signal is shaped to determine output pulse width. This mode can be used for pulse recovery. |

Optional Modes

The following additional trigger modes are available with Option 001:

- I.SWP** In internal sweep mode the instrument repeatedly sweeps the output frequency logarithmically between specified start and stop frequencies. The sweep time per frequency decade is selectable between 10 ms and 500 s in intervals in the ratio 1:2:5.
- E.SWP** In external sweep mode an external trigger initiates a single sweep cycle. A second trigger is required to reset the instrument to the start frequency.
- I.BUR** In internal burst mode the instrument repeatedly generates a specified number of output cycles (in the range 1 to 1999). The time between bursts can be selected in the range 100 ns to 999 ms.
- E.BUR** In external burst mode an external trigger initiates an output burst.

Note



The maximum output frequency in a burst mode is 40 MHz

Controlling the External Trigger

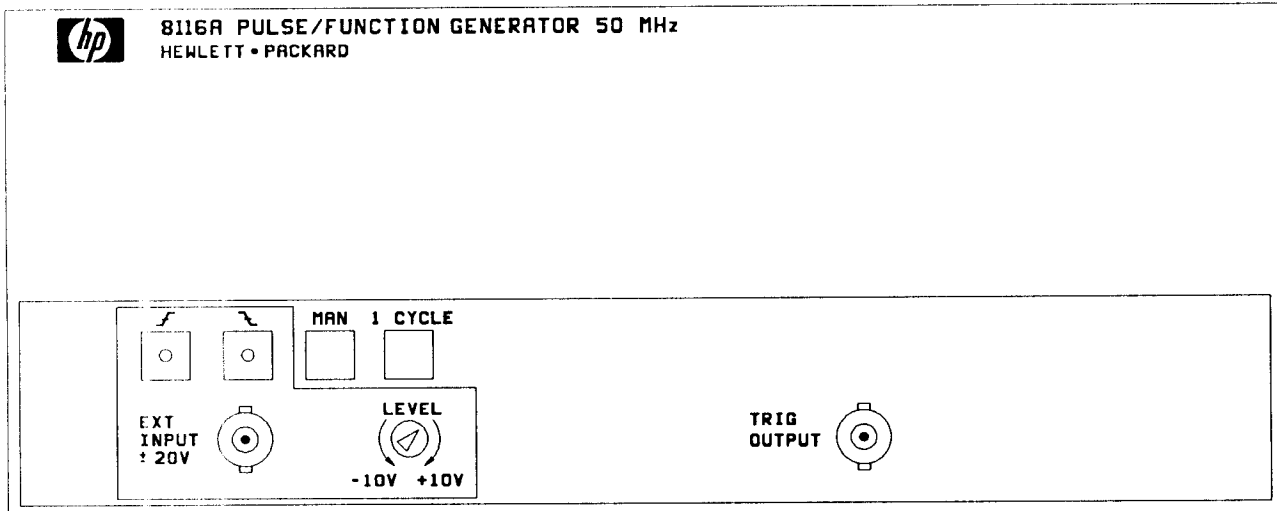

Figure 4-3. External Trigger Controls



The external trigger signal required in some trigger modes must be applied to the **EXT INPUT** BNC connector.

Caution



Do not apply voltages outside the range ± 20 V to the **EXT INPUT** connector.

Trigger Slope

Select a positive or negative trigger slope by pressing the  or  key respectively.

The current trigger slope is indicated by the LED on the key.

The trigger can be switched off by pressing the currently active key again. Both key LEDs will then be off.

Trigger Level

The trigger level can be varied in the range ± 10 V using the **LEVEL** adjuster.

Manual Trigger



This key can be used to simulate the external trigger signal.

Single Cycle

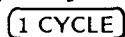

This key initiates a single output cycle in GATE, I.BUR and E.BUR modes.

Trigger Output

The trigger output provides a timing reference signal synchronised to the main output signal. Output levels are 0 and 2.4 V into 50 Ω .

Selecting Control Mode

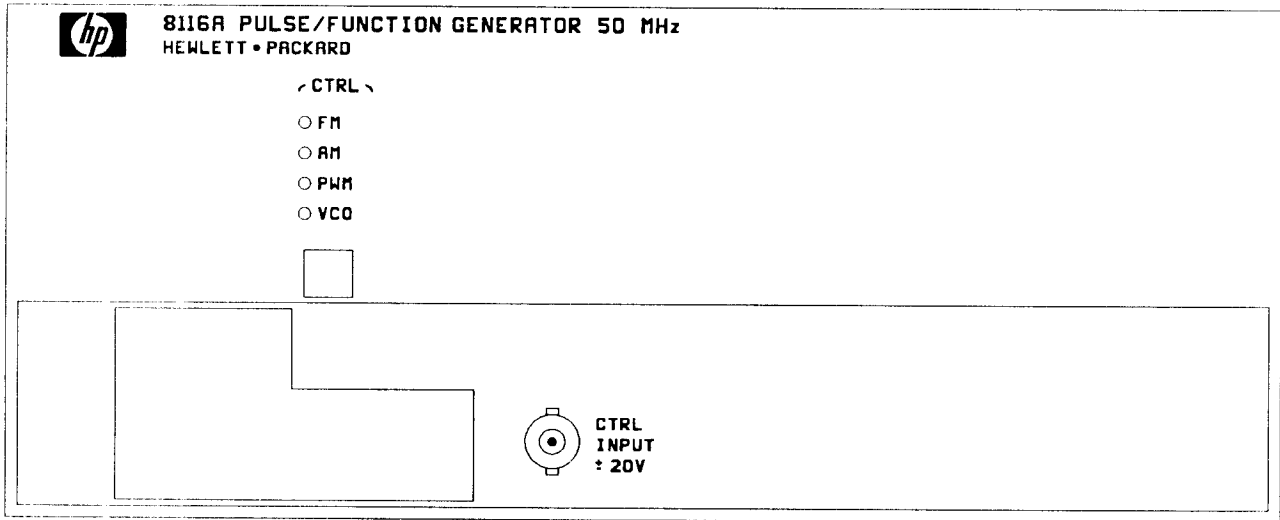

Figure 4-4. Control mode controls

Control Input

A signal can be applied to the control input to modulate or control the HP 8116A output signal.

Caution



Do not apply voltages outside the range ± 20 V to the CTRL INPUT connector.

Mode Selection

The currently active mode is shown by LED indicator. The trigger mode can be cycled through available options by pressing the key below the mode indicators. Figure 4-5 indicates the permitted combinations of control mode, trigger mode and output waveform:

		TRIGGER							
		NORM	TRIG	GATE	E. WID	I. SWP	E. SWP	I. BUR	E. BUR
CONTROL	FM	•	•	•	✗	•	•	⌘	•
	AM	•	•	•	⌘	•	•	⌘	•
	PWM	⌘	⌘	⌘	✗	⌘	⌘	✗	⌘
	VCO	•	•	•	✗	✗	✗	•	•

• = All waveforms ✗ = Invalid combination
 ⌘ = Pulse waveform only ⌘ = All waveforms except pulse

Figure 4-5. Trigger & Control mode combinations

Frequency Modulation FM

The output signal frequency can be modulated to a maximum of $\pm 5\%$ of the programmed value by applying a control voltage in the range ± 6 V.

Amplitude Modulation AM

The output signal amplitude can be modulated from 0 to 100% using a ground-symmetrical control voltage in the range ± 2.5 V. Double Side Band Supressed Carrier (DSBSC) is obtained using a control voltage in the range $+2.5$ V to -7.5 V which gives 200% modulation.

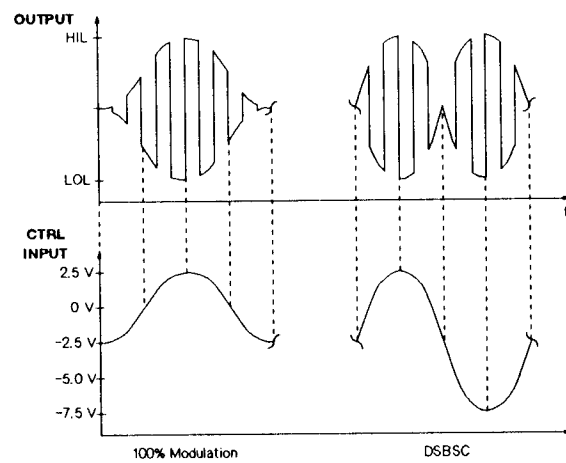

Figure 4-6. Amplitude Modulation

Pulse Width Modulation PWM

In pulse mode, the pulse width can be controlled using a control voltage in the range ± 6.5 V. There are 8 non-overlapping pulse width ranges available, as shown below:

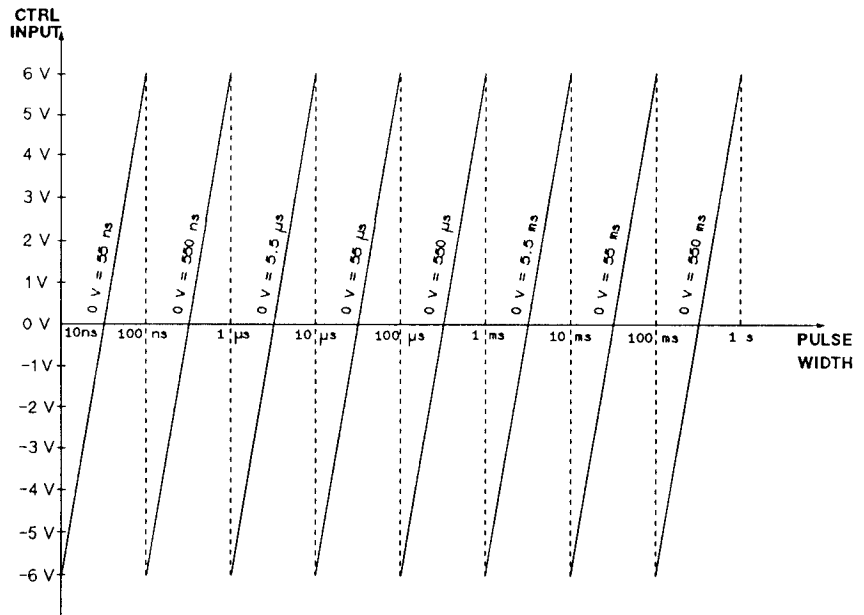

Figure 4-7. Pulse Width Modulation characteristics

The pulse width range can be chosen by selecting the WID parameter. The pulse width for a CTRL INPUT voltage of 0 V is displayed. Use the **RANGE** key to move between ranges.

Note



The available pulse width ranges are limited by the current output frequency.

Voltage Controlled Oscillator VCO

The output signal frequency can be controlled linearly over 2 decades by applying a control voltage in the range 0.1 V to 10 V. Eleven overlapping frequency ranges are available:

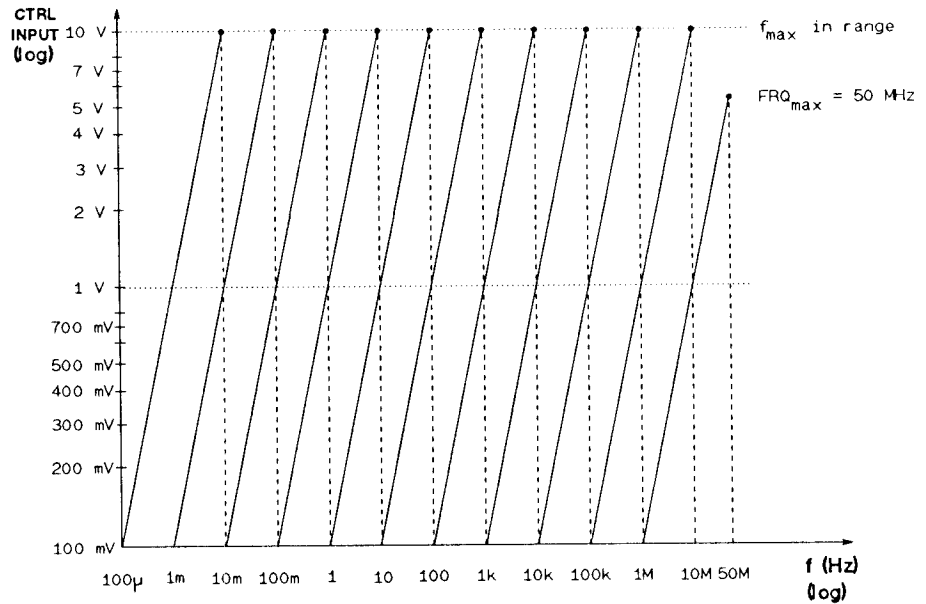

Figure 4-8. VCO characteristics

The output frequency range can be chosen by selecting the FRQ parameter. The maximum frequency in the current VCO range is displayed. Use the **RANGE** key to move between ranges.

Selecting Output Waveform

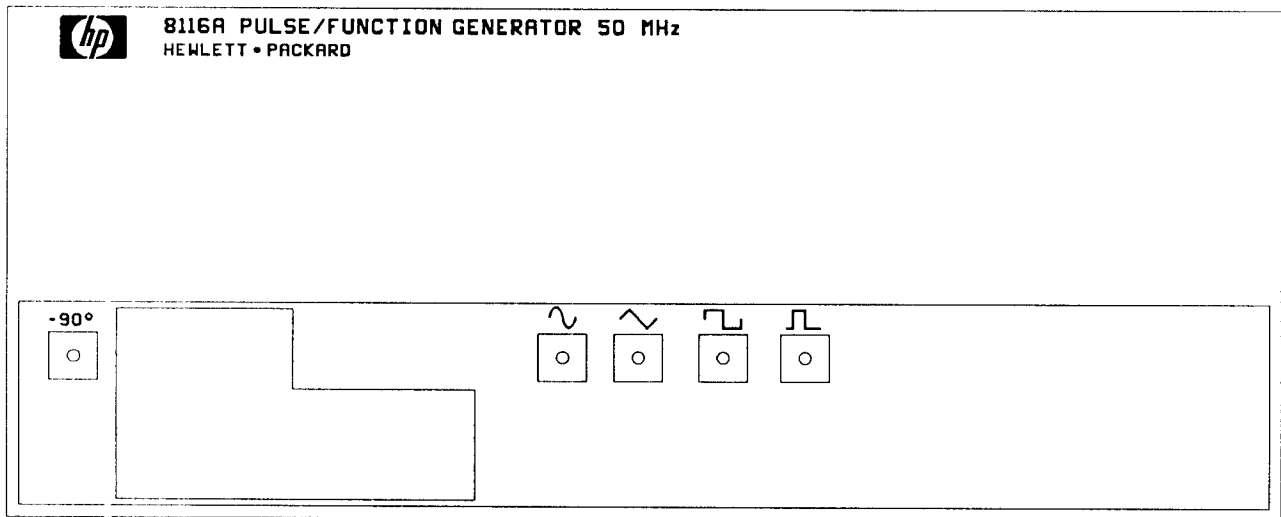

Figure 4-9. Waveform controls

Waveform Select the desired waveform by pressing the appropriate key. The key LED illuminates to indicate the current waveform.

To select DC output, make sure that the output amplitude (AMP) is ≥ 100 mV and then press the currently active (LED illuminated) waveform key again. All waveform-key LEDs will now be off, indicating DC output has been selected.

Start Phase This key selects an output start phase of -90° in TRIG, GATE, I.BUR and E.BUR modes. This allows haversine and havertriangle outputs to be generated.

-90°

Setting Parameters

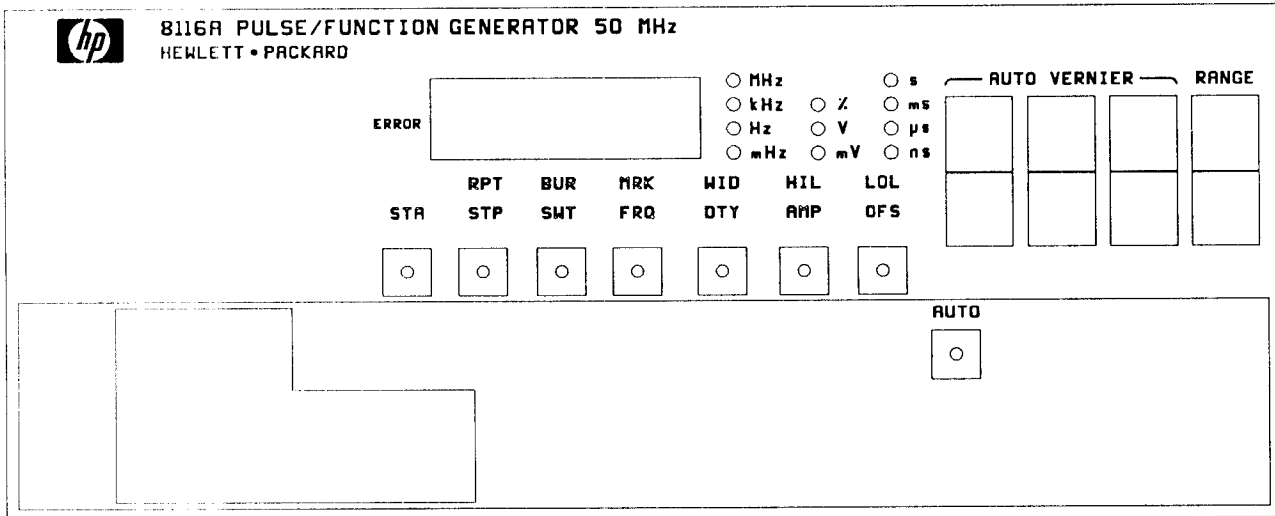

Figure 4-10. Parameter controls

The parameters available for selection depend on the currently selected modes and waveform. All parameters are listed below; timing and level parameters are illustrated in Figure 4-11 and Figure 4-12

Standard	Opt. 001	Description
AMP		Output amplitude
BUR		Output burst length in cycles
DTY		Duty cycle
FRQ		Output frequency
HIL		High level of output
LOL		Low level of output
	MRK	Marker frequency
OFS		Output signal offset
	RPT	Repeat interval
	STA	Start frequency
	STP	Stop frequency
	SWT	Sweep time
WID		Pulse width

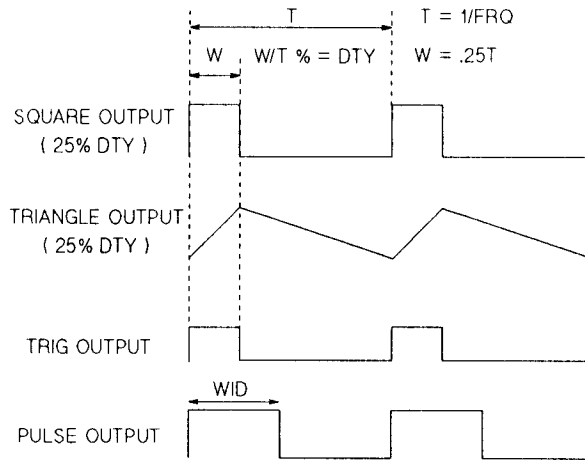

Figure 4-11. Timing parameters

Selection Pressing a parameter key selects the parameter indicated by the illuminated mnemonic above the key.

Note 

Output level can be set in terms of amplitude (AMP) and offset (OFS), or in terms of high and low level (HIL,LOL). Refer to Figure 4-12. Pressing the appropriate parameter key a second time will select the alternative parameter associated with that key.

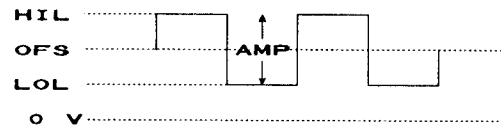

Figure 4-12. Level parameters

The current value of the selected parameter is shown on the digital display. The parameter units are indicated by the LEDs to the right of the display.

Adjustment The currently selected parameter is adjusted using the **VERNIER** and **RANGE** rocker keys. Each **VERNIER** key increments or decrements the corresponding digit in the digital display. Similarly, the **RANGE** key increases or decreases the parameter value by a factor of 10.

Autovernier

AUTO

In normal trigger mode only, a chosen parameter can be automatically incremented or decremented with selectable resolution. Pressing the **AUTO** key enables the Autovernier, which can then be started by pressing a **VERNIER** key. The **VERNIER** key determines the direction and step size used.

The Autovernier continues until one of the following conditions arises:

- A timing error occurs
- An instrument specification limit is reached
- An output level limit is reached

Autovernier mode can be switched off by:

- An external trigger input.
- Pressing the **AUTO** key again.
- Pressing any key other than the **VERNIER** keys.

Selecting Output Mode

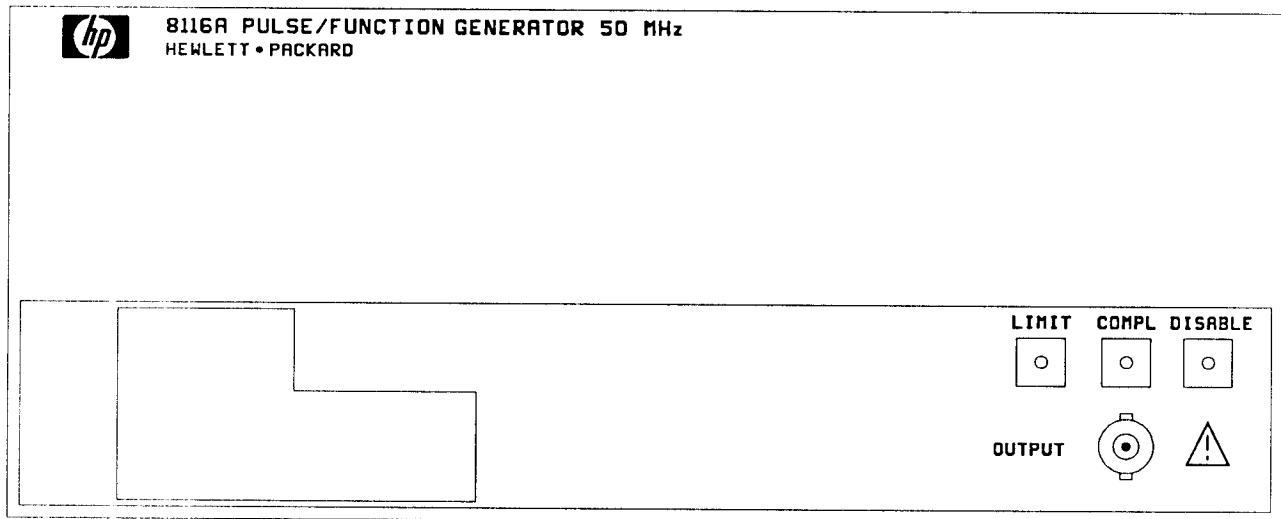

Figure 4-13. Output controls

Limited Output

LIMIT

Pressing the **LIMIT** key sets the current high and low output levels (HIL,LOL) as output limits which cannot be exceeded until limited output mode is switched off. While limited output mode is active, the high and low output levels (HIL,LOL) can be varied within the output limits.

Limited output mode is switched off by pressing the **LIMIT** key again. The **LIMIT** key LED is lit when this mode is active.

Complement Output

COMPL

Pressing the **COMPL** key complements the instrument output, pressing the key again returns the instrument output to normal.

The **COMPL** key LED is lit when the output is complemented.

Disabled Output

DISABLE

Pressing the **DISABLE** key disables the instrument output, pressing the key again enables the output.

The **DISABLE** key LED is lit when the output is disabled.

Rear Panel

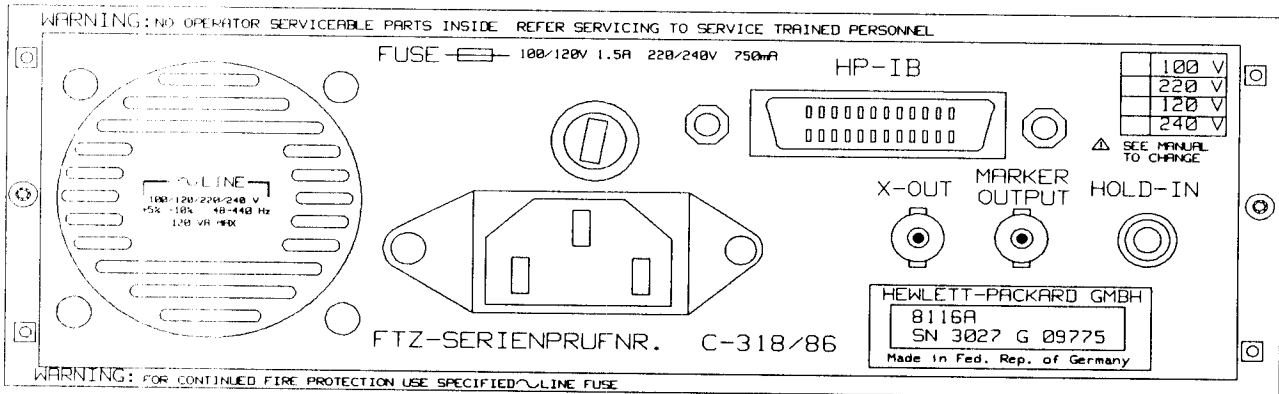

Figure 4-14. Rear panel

HP-IB Connector

Refer to Figure 3-3 for a definition of the HP-IB connector pins. Refer to "Setting the HP-IB Address" in Chapter 6 if you want to know how to set the instrument's HP-IB address.

Hold Input (Option 001)

The hold input is a TTL compatible input which freezes the output signal when a high level (> 2.5 V) signal is received.

The hold input function only operates for sine, triangle and squarewaves at frequencies < 10 Hz.

X-Output (Option 001)

The X-Output provides an increasing output voltage with logarithmically increasing frequency in sweep modes.

0 V always corresponds to the sweep start frequency. The voltage increases at 1.5 V per frequency decade to a maximum of 10 V.

Marker Output (Option 001)

The marker output generates a TTL level positive edge (0 to 2.4 V into 50Ω) when the instrument frequency reaches the preprogrammed marker frequency during a sweep.

Fuse

The fuseholder accepts standard fuses to provide instrument protection in case of current overload. Refer to Table 3-1 for appropriate fuse selection.

Operating Examples

Introduction

The following examples show how the instrument can be set up for each type of trigger mode. The examples list the basic operating steps in the order in which they would normally occur after switching on.

Normal Mode

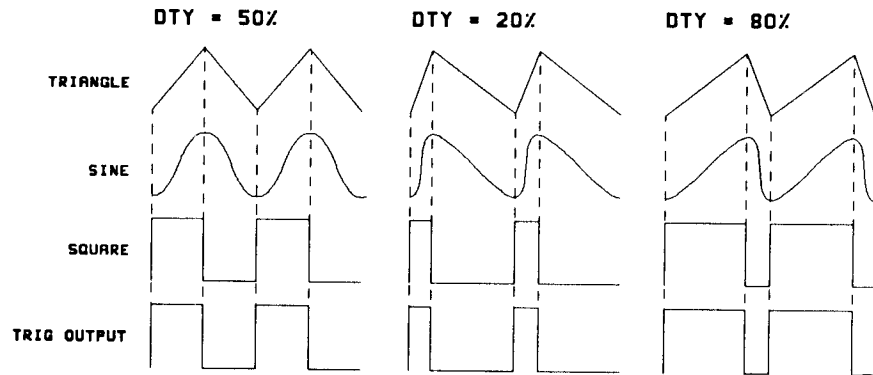

Figure 5-1. Typical outputs in Normal mode

1. Switch the instrument on using the line switch.
2. If necessary, select normal mode by repeatedly pressing the standard mode key until the NORM LED is lit.
3. Select the desired output waveform by pressing the key with the appropriate symbol.
4. Select each output parameter in turn by pressing its associated key. Adjust the parameter value using the **VERNIER** and **RANGE** keys. Refer to “Setting Parameters” in Chapter 4 for additional information on parameter adjustment.

Note



For level parameters HIL, LOL, AMP, OFS, pressing the parameter key a second time will select the alternative parameter associated with that key.

5. If a modulated output is required, select the required modulation using the **CTRL** key. Apply the modulating signal to the CTRL INPUT connector. Refer to “Selecting Control Mode” in Chapter 4 for more information on modulating the output signal.

Note



You may wish to set up Output Limits as described in “Selecting Output Mode” in Chapter 4 to protect the device under test.

6. Press the **DISABLE** key to turn off output disable mode and enable the output.

Trig Mode

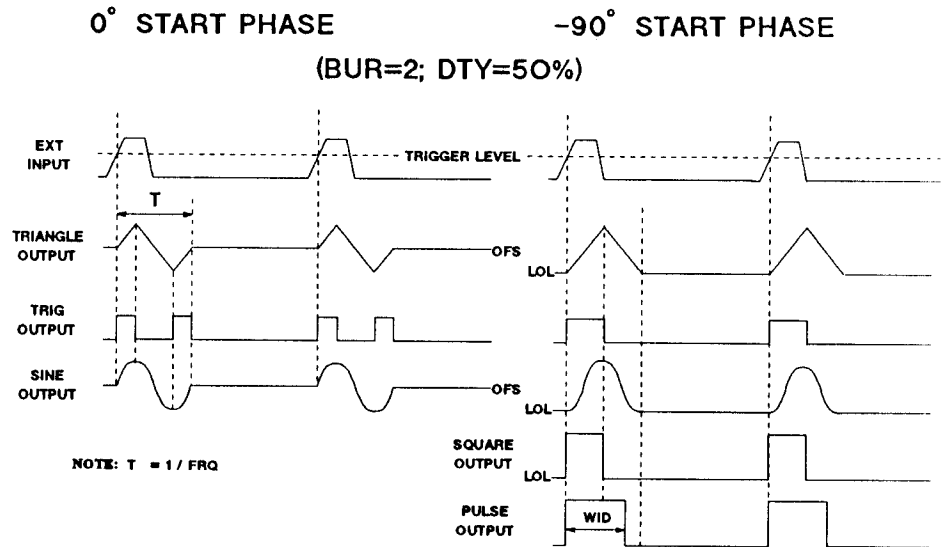

Figure 5-2. Typical signals in Trigger mode

1. Switch the instrument on using the line switch.
2. If necessary, select Trig mode by repeatedly pressing the standard mode key until the TRIG LED is lit.
3. Select the desired output waveform by pressing the key with the appropriate symbol.
4. Select each output parameter in turn by pressing its associated key. Adjust the parameter value using the **VERNIER** and **RANGE** keys. The selected frequency FRQ must be higher than the external trigger frequency. Refer to "Setting Parameters" in Chapter 4 for additional information on parameter adjustment.

Note



For level parameters HIL, LOL, AMP, OFS, pressing the parameter key a second time will select the alternative parameter associated with that key.

5. Apply the external trigger signal to the EXT INPUT and select trigger slope and level as required. Refer to "Controlling the External Trigger" in Chapter 4 for information on the trigger controls. Triggering can also be simulated using the **MAN** key.
6. If a modulated output is required, select the required modulation using the **CTRL** key. Apply the modulating signal to the CTRL INPUT connector. Refer to "Selecting Control Mode" in Chapter 4 for more information on modulating the output signal.

Note



You may wish to set up Output Limits as described in "Selecting Output Mode" in Chapter 4 to protect the device under test.

7. Press the **DISABLE** key to turn off output disable mode and enable the output.

Gate Mode

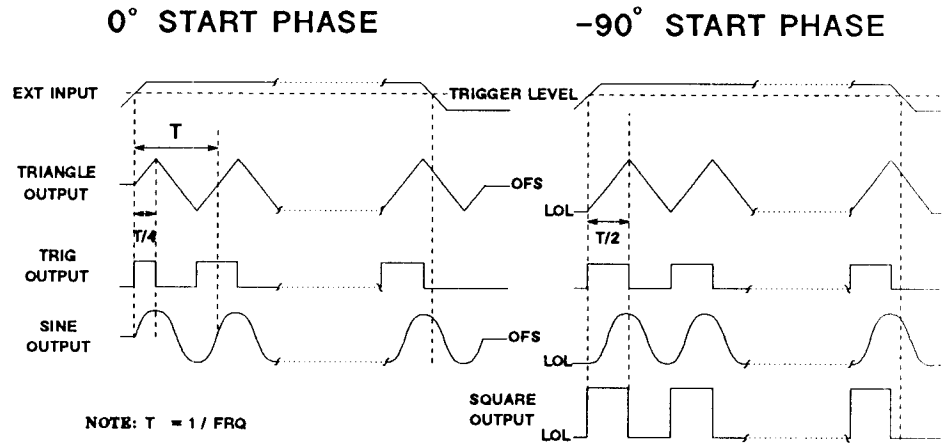

Figure 5-3. Typical signals in Gate mode

1. Switch the instrument on using the line switch.
2. If necessary, select gate mode by repeatedly pressing the standard mode key until the gate LED is lit.
3. Select the desired output waveform by pressing the key with the appropriate symbol.
4. Select each output parameter in turn by pressing its associated key. Adjust the parameter value using the **VERNIER** and **RANGE** keys. Refer to “Setting Parameters” in Chapter 4 for additional information on parameter adjustment.

Note



For level parameters HIL, LOL, AMP, OFS, pressing the parameter key a second time will select the alternative parameter associated with that key.

5. Apply the external gating signal to the EXT INPUT and select trigger slope and level as required. Refer to “Controlling the External Trigger” in Chapter 4 for information on the trigger controls. Triggering can also be simulated using the **MAN** key.
6. If a modulated output is required, select the required modulation using the **CTRL** key. Apply the modulating signal to the CTRL INPUT connector. Refer to “Selecting Control Mode” in Chapter 4 for more information on modulating the output signal.

Note



You may wish to set up Output Limits as described in “Selecting Output Mode” in Chapter 4 to protect the device under test.

7. Press the **DISABLE** key to turn off output disable mode and enable the output.

External Width Mode

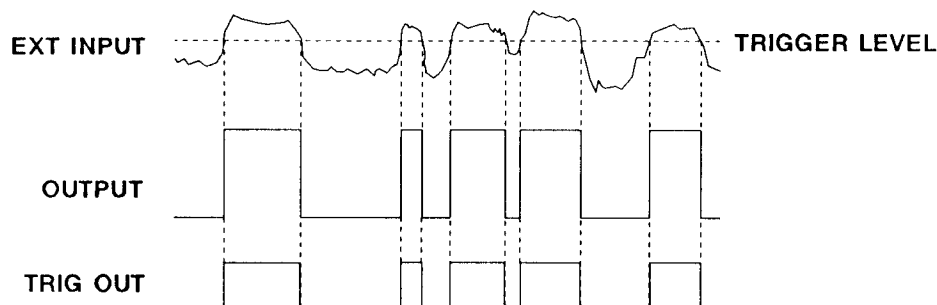

Figure 5-4. Typical signals in External Width mode

1. Switch the instrument on using the line switch.
2. If necessary, select external width mode by repeatedly pressing the standard mode key until the E.WID LED is lit.
3. Select pulse waveform by pressing the key with the appropriate symbol.
4. Select each output parameter in turn by pressing its associated key. Adjust the parameter value using the **VERNIER** and **RANGE** keys. Refer to “Setting Parameters” in Chapter 4 for additional information on parameter adjustment.

Note



For level parameters HIL, LOL, AMP, OFS, pressing the parameter key a second time will select the alternative parameter associated with that key.

5. Apply the external signal to be shaped to the EXT INPUT and select trigger slope and level as required. Refer to “Controlling the External Trigger” in Chapter 4 for information on the trigger controls.
6. If an amplitude modulated output is required select AM control mode using the **CTRL** key and apply the modulating signal to the CTRL INPUT connector.

Note



You may wish to set up Output Limits as described in “Selecting Output Mode” in Chapter 4 to protect the device under test.

7. Press the **DISABLE** key to turn off output disable mode and enable the output.

Sweep Modes

1. Switch the instrument on using the line switch.
2. If necessary, select the required sweep mode by repeatedly pressing the optional mode key until the I. or E. SWP LED is lit.
3. Select the desired output waveform by pressing the key with the appropriate symbol.
4. Select each output parameter in turn by pressing its associated key. Adjust the parameter value using the **VERNIER** and **RANGE** keys. Refer to “Setting Parameters” in Chapter 4 for additional information on parameter adjustment. The sweep related parameters STA, STP, SWT, MRK are illustrated in the following timing diagrams.

Note



For level parameters HIL, LOL, AMP, OFS, pressing the parameter key a second time will select the alternative parameter associated with that key.

5. In External Sweep mode apply the external trigger signal to the EXT INPUT and select trigger slope and level as required. Refer to “Controlling the External Trigger” in Chapter 4 for information on the trigger controls. Triggering can also be simulated using the **MAN** key. In either case remember that two triggers are required to complete one sweep, as shown in the following timing diagrams.
6. If a modulated output is required, select the required modulation using the **CTRL** key. Apply the modulating signal to the CTRL INPUT connector. Refer to “Selecting Control Mode” in Chapter 4 for more information on modulating the output signal.

Note



You may wish to set up Output Limits as described in “Selecting Output Mode” in Chapter 4 to protect the device under test.

7. Press the **DISABLE** key to turn off output disable mode and enable the output.

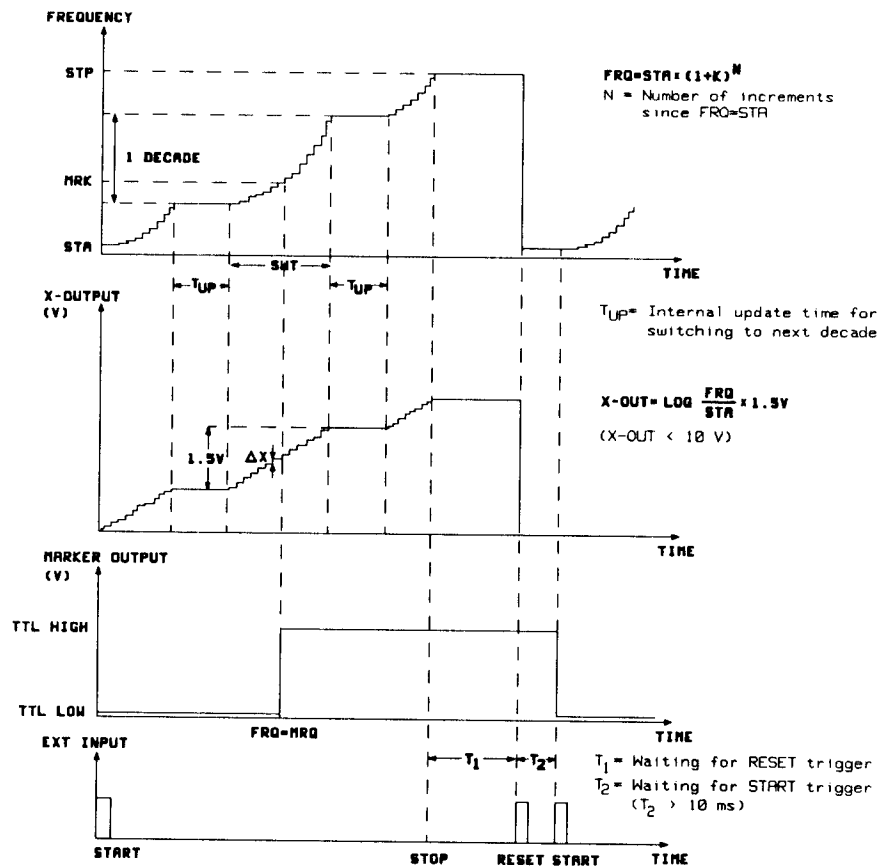

Figure 5-5. Sweep Mode Signals

Table 5-1.

SWT	K	N	ΔX
10 ms	0.0625	38	40 mV
20 ms	0.03125	75	20 mV
50 ms	0.015625	149	10 mV
100 ms	0.015625	149	10 mV
200 ms	0.015625	149	10 mV
500 ms	0.015625	149	10 mV
1 s	0.015625	149	10 mV
2 s	0.015625	149	10 mV
5 s	0.015625	149	10 mV
10 s	0.015625	149	10 mV
20 s	0.015625	149	10 mV
500 s	0.015625	149	10 mV
100 s	0.015625	149	10 mV
200 s	0.015625	149	10 mV
500 s	0.015625	149	10 mV

Burst Modes

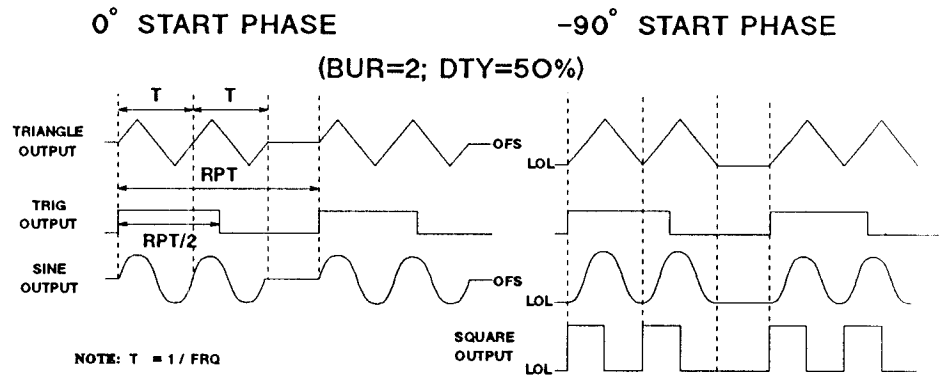

Figure 5-6. Typical outputs in Internal Burst mode

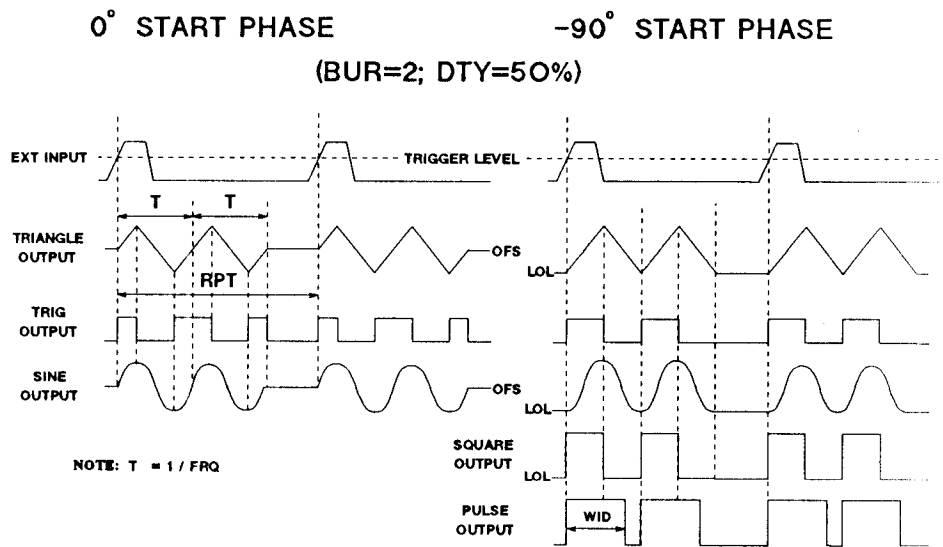

Figure 5-7. Typical signals in External Burst mode

1. Switch the instrument on using the line switch.
2. If necessary, select the required burst mode by repeatedly pressing the optional mode key until the I. or E. BUR LED is lit.
3. Select the desired output waveform by pressing the key with the appropriate symbol.
4. Select each output parameter in turn by pressing its associated key. Adjust the parameter value using the **VERNIER** and **RANGE**

keys. Refer to “Setting Parameters” in Chapter 4 for additional information on parameter adjustment. The burst related parameters BUR, RPT, are illustrated in the timing diagrams which follow.

Note



For level parameters HIL, LOL, AMP, OFS, pressing the parameter key a second time will select the alternative parameter associated with that key.

5. In external burst mode apply the external trigger signal to the EXT INPUT and select trigger slope and level as required. Refer to “Controlling the External Trigger” in Chapter 4 for information on the trigger controls. Triggering can also be simulated using the **MAN** key.
6. If a modulated output is required, select the required modulation using the **CTRL** key. Apply the modulating signal to the CTRL INPUT connector. Refer to “Selecting Control Mode” in Chapter 4 for more information on modulating the output signal.

Note



You may wish to set up Output Limits as described in “Selecting Output Mode” in Chapter 4 to protect the device under test.

7. Press the **DISABLE** key to turn off output disable mode and enable the output.

Programming

General

In remote mode, all HP 8116A settings, except the EXT INPUT trigger level, are programmable via the HP-IB. The HP 8116A also provides error messages and reports operating parameters when requested by the controller.

In addition, the instrument responds to a sub-set of the universal HP-IB commands.

This chapter describes the valid programming mnemonics and syntax for the HP 8116A. Example program statements are based on HP BASIC 5.0/5.1 for the HP 9000 Series 200/300 controllers. Example program statements also assume that the instrument's HP-IB address is 16 decimal.

This manual does not discuss the HP-IB protocol or hardware. For more information refer to any of the following publications:

- IEEE Interface Standard 488.1
- ANSI Interface Standard MC1.1.
- HP Publication 59401-90030
- HP Publication 5952-0058
- HP Publication 5952-0156

Setting the HP-IB Address

The HP 8116A's HP-IB address is set at the factory to 16 decimal. The address is stored in the instrument's RAM, along with the current instrument settings.

Note



- *You can only change the address in NORMAL trigger mode, immediately after switching the instrument on. Pressing the **LCL** key at any other time displays the current address while the key is depressed, but no change is possible.*
- When allocating HP-IB addresses make sure no instruments on the bus have the same address.
- If the RAM battery fails, the HP-IB address is set to 16 when the instrument is switched on.

To change the instrument's HP-IB address:

1. Switch the instrument on.
2. If the instrument is NOT in NORM trigger mode:
 - a. Select NORM trigger mode.
 - b. Switch the instrument off and on again.

3. Press the **LCL** key. The current HP-IB address is displayed on the frontpanel.
4. Use the vernier keys to change the address.
5. Press the **LCL** key again to set the new address.

Local, Remote and Local Lockout

Local mode

In this mode the RMT LED is off, the front panel is used to operate the instrument and programming messages are ignored.

You can select local mode in the following ways:

- Switching the HP 8116A on.
- Pressing the **LCL** key, if Local Lockout is inactive.
- Sending an HP-IB Local command to the instrument from the system controller (use the LOCAL statement in BASIC 5.0/5.1).

The output signal and all instrument settings remain unchanged following a change from remote to local mode.

Remote mode

In this mode the RMT LED is illuminated and programming messages received via the HP-IB are interpreted (parsed) and used to control the instrument. The front panel controls are disabled apart from:

- The **LINE** switch.
- The trigger LEVEL adjust knob.
- The **LCL** key, if Local Lockout is inactive.

You can select remote mode by sending an HP-IB Remote Enable command from the system controller (use the REMOTE statement in BASIC 5.0/5.1).

The output signal and all instrument settings remain unchanged following a change from local to remote mode.

Local Lockout

The **LCL** key can be disabled by sending an HP-IB Local Lockout command from the system controller (use the LOCAL LOCKOUT statement in BASIC 5.0/5.1). This ensures that only the system controller can return the instrument to Local mode, except if the instrument is switched off and on again.

It is recommended that all programming applications use this facility as, if a programming message is interrupted by pressing the **LCL** key during data transmission from the system controller, the HP 8116A may be left in an unknown state.

Introduction

Multiple programming commands can be put in a single programming message, for example:

```
OUTPUT 716;"M1,TO,FRQ 1 KHZ"
```

- It is not necessary to put a comma between commands, a space will do.
- The HP 8116A understands upper and lower case commands.
- Commands which change modes are processed before commands which set parameters, irrespective of the command order within the programming message. If your application requires a parameter change to occur before a mode change, use separate programming messages for the two commands.

The HP 8116A can be programmed into an error condition in the same ways as when using the front panel. For example, attempting to program a larger LOL than HIL:

```
OUTPUT 716;"HIL 1 V,LOL 2 V"
```

Refer to “Error, Fault and Status Reporting” for details of error, fault and status reporting using the HP-IB.

The HP 8116A needs time to interpret and implement the commands which it receives. You need to allow for this in your controller program. A summary of programming timings is given in “Message Interpretation times” in Chapter 2.

Selecting Trigger Modes

Standard Trigger Modes

Action	Mnemonic
Select NORM	M1
Select TRIG	M2
Select GATE	M3
Select E.WID	M4

Option 001 Trigger Modes

Action	Mnemonic
Select I.SWP	M5
Select E.SWP	M6
Select I.BUR	M7
Select E.BUR	M8

Trigger Control

Action	Mnemonic
Select trigger off	T0
Select positive trigger slope	T1
Select negative trigger slope	T2

Example

OUTPUT 716;"M3,T1" *Select GATE mode with a positive trigger slope.*

Selecting Control Modes

Action	Mnemonic
Switch off control mode	CT0
Select FM	CT1
Select AM	CT2
Select PWM	CT3
Select VCO	CT4

Example `OUTPUT 716;"CT2"` *Select Amplitude Modulation.*

Selecting Output Waveform

Action	Mnemonic
Select DC	W0
Select sine	W1
Select triangle	W2
Select square	W3
Select pulse	W4
Select 0° (normal) startphase	H0
Select -90° startphase	H1

Example `OUTPUT 716;"W1,H0"` *Select sinewave output with 0° startphase.*

Setting Parameters

Note



A parameter's programming mnemonic is the same as its front panel description, AMP = amplitude for example.

Timing parameters

Action	Mnemonic	Value Delimiter
Set frequency	FRQ	MZ = millihertz HZ = hertz KHZ = kilohertz MHZ = megahertz
Set duty cycle	DTY	%
Set pulse width	WID	NS = nanoseconds US = microseconds MS = milliseconds

Example

OUTPUT 716;"FRQ 2.5 KHZ,DTY 30 %" *Set frequency to 2.5 kHz,
set duty cycle to 30%.*

Level parameters

Action	Mnemonic	Value Delimiter
Set amplitude	AMP	MV = millivolts V = volts
Set offset	OFS	MV = millivolts V = volts
Set high level	HIL	V = volts
Set low level	LOL	V = volts

Example

OUTPUT 716;"OFS -1 V,AMP 100 MV" *Set output offset to -1 V,
set amplitude to 100 mV.*

Option 001 Parameters

Action	Mnemonic	Value Delimiter
Set burst number	BUR	#
Set repeat interval	RPT	NS = nanoseconds US = microseconds MS = milliseconds
Set start frequency	STA	MZ = millihertz HZ = hertz KHZ = kilohertz MHZ = megahertz
Set stop frequency	STP	MZ = millihertz HZ = hertz KHZ = kilohertz MHZ = megahertz
Set marker frequency	MRK	MZ = millihertz HZ = hertz KHZ = kilohertz MHZ = megahertz
Set sweep time	SWT	MS = milliseconds S = seconds

Example

OUTPUT 716;"STA 2 KHZ,STP 100 KHZ,SWT 2 S" *Set up a start frequency of 2 kHz, a stop frequency 100 kHz and a sweeptime of 2 s.*

Autovernier

Note



Autovernier mode must be switched on before using the digit up/down commands.

Action	Mnemonic
Switch off autovernier	A0
Switch on autovernier	A1
Most significant digit up	MU
Second significant digit up	SU
Least significant digit up	LU
Most significant digit down	MD
Second significant digit down	SD
Least significant digit down	LD

Example

OUTPUT 716;"OFS 120 MV,A1,LU" *Set offset to 120 mV and increment in steps of 1mV.*

Reading parameters

It is possible to read the current setting of a parameter using the interrogation mnemonics listed here:

- Standard**
- IFRQ
 - IDTY
 - IWID
 - IAMP
 - IOFS
 - IHIL
 - ILOL

- Option 001**
- IBUR
 - IRPT
 - ISTA
 - ISTP
 - IMRK
 - ISWT

The HP 8116A reply has the same format as that used when setting the parameter, for example:

FRQ 1.00KHZ

The reply length is always 12 characters.

It is also possible to read all the instrument settings in one go using the CST mnemonic. Refer to "Reading the Current Settings"

Example	DIM B\$[12]	<i>Allocate memory for reply.</i>
	OUTPUT 716;"IFRQ"	<i>Request current frequency setting.</i>
	ENTER 716;B\$	<i>Read reply into allocated memory.</i>

Selecting Output Modes

Output Controls

Action	Mnemonic
Switch off output limits	L0
Switch on output limits	L1
Switch off complementary output	C0
Complement output	C1
Enable output	D0
Disable output	D1

Example

OUTPUT 716;"L1,D0" *Switch on output limits and enable the output signal.*

Reading the Current Settings

The system controller can request the current instrument settings using the mnemonic **CST**.

The HP 8116A replies with a string containing all current settings. The data is always in the same order, but the level parameter data can be either **HIL/LOL** or **AMP/OFS** :

AMP and OFS active

```
M1,CTO,T1,W1,HO,AO,LO,CO,D1,BUR 001 #,RPT 100 MS,  
STA 1.00 KHZ,STP 100 KHZ,SWT 50.0 MS,MRK 1.00 KHZ,  
FRQ 1.00 KHZ,DTY 50 %,WID 100 US,AMP 1.00V,OFS 100 MV
```

HIL and LOL active

```
M1,CTO,T1,W1,HO,AO,LO,CO,D1,BUR 001 #,RPT 100 MS,  
STA 1.00 KHZ,STP 100 KHZ,SWT 50.0 MS,MRK 1.00 KHZ,  
FRQ 1.00 KHZ,DTY 50 %,WID 100 US,HIL 0.30 V,LOL -0.70 V
```

The examples shown are for an instrument with Option 001 fitted. In this case the maximum reply length is 161 characters, for a standard instrument the maximum reply length is 89 characters.

Example

```
DIM B$[161]  
OUTPUT 716;"CST"  
ENTER 716;B$
```

Allocate memory for maximum reply length
Request current instrument settings
Read reply into allocated memory

Timing

The time taken for the HP 8116A to receive and implement a programming message can be divided into three parts:

Data Transmission Time

This is the time taken to transmit the programming message over the HP-IB, which is 130 μ s per ASCII character. The system controller is free to continue with its program after this time.

Implementation Time

This is the time taken by the HP8116A to interpret and carry out all the commands in received message. Typical implementation times for various commands are given in the following table.

Table 6-1.

Command(s)	Implementation Time
Mode change	11 ms
W0 - W3	24 ms
W4	330 ms
FRQ	60 ms
DTY	60 ms
WID	24 ms
HIL	110 ms
LOL	100 ms
AMP	150 ms
OFS	150 ms
D0,D1,L0,L1,C0,C1	60 ms

The timings given are worst case. When parameter settings are combined into one programming message, the combined implementation time can be up to 40% more efficient.

The Buffer Not Empty flag in the HP 8116A status byte is set during this time. The system controller can therefore monitor this flag to detect when a programming message has been implemented. Refer to "Error, Fault and Status Reporting".

Hardware Settling Time

The hardware requires time to settle after a change. This takes longer than the interpretation time in some cases:

- When changing frequency, duty cycle, pulse width or amplitude, allow an additional 5 ms settling time.
- When changing offset or selecting DC output, allow an additional 30 ms settling time.

Error, Fault and Status Reporting

HP-IB Status Byte

The HP 8116A has an 8 bit status byte which can be read using a serial poll.

`A = SPOLL(716)` *Read instrument status byte into variable A*

The meaning of each bit in the status byte is given below. In all cases, the bit is set to 1 to indicate that the condition described is true.

Bit	Meaning
0	TIMING ERROR (Causes SRQ)
1	PROGRAMMING ERROR (Causes SRQ)
2	SYNTAX ERROR (Causes SRQ)
3	SYSTEM FAILURE (Causes SRQ)
4	AUTOVERNIER IN PROGRESS
5	SWEEP IN PROGRESS
6	SERVICE REQUEST (=SRQ)
7	BUFFER NOT EMPTY

The SRQ bit generates an interrupt at the system controller to indicate that the instrument requires attention. You can use this facility as the basis of interrupt driven error handling in your programming application.

The SRQ, Programming Error, Syntax Error and System Error bits are latched until the status byte is polled by the system controller. The other status bits represent the current condition at the time the status byte is read.

You can obtain more detailed information about timing and programming errors using the interrogate error (**IERR**) mnemonic. The HP 8116A responds with a string describing the current error conditions. The descriptions are covered in subsequent parts of this section.

```
DIM E$[45]                    Allocate memory for error string
OUTPUT 716;"IERR"            Request error information
ENTER 716;E$                 Read reply into allocated string
```

**Timing Error
(Bit 0)**

There are three (four with Opt 001) types of error which set the timing error bit in the status byte. The conditions which cause them and the description used by the HP 8116A when replying to an **IERR** command are listed below. The timing error bit is not latched, therefore a transient error is only recorded by generating an **SRQ**.

Note



More than one error condition can occur at one time. When using the **IERR** command ensure that you allow for a reply containing more than one error description.

IERR Description	Comments
WAVEFORM ERROR	<ul style="list-style-type: none">■ This error occurs if you request an invalid combination of trigger mode, control mode and waveform. Refer to Figure 4-5 for the permitted combinations.■ The front panel LEDs flash to indicate the invalid settings.■ The instrument's output is not affected.
DUTY C. ERROR	<ul style="list-style-type: none">■ This error occurs if you request an invalid combination of frequency and duty cycle. Refer to "Duty Cycle" in Chapter 2 for the valid combinations.■ The instrument's output is not affected.
WIDTH ERROR	<ul style="list-style-type: none">■ This error occurs if you request an invalid combination of frequency and pulse width so that: $WID > 1/FRQ$.■ The instrument's output changes.■ You can use the SR1 command to stop this error generating a timing error and an SRQ. To re-enable it, use the SR0 command. The response to IERR is not affected.
TIMING ERROR	<ul style="list-style-type: none">■ This error can only occur with Opt 001 in LBUR mode.■ This error occurs if you request an invalid combination of frequency, burst number and repeat time so that: $BUR \times 1/FRQ > RPT$.■ The instrument's output changes.■ You can use the SR1 command to stop this error generating a timing error and an SRQ. To re-enable it, use the SR0 command. The response to IERR is not affected.

**Programming Error
(Bit 1)**

There are three types of error which cause the programming error bit in the status byte to be set. The following list gives the conditions which cause them and the description used by the HP 8116A when replying to an **IERR** command. The programming error bit is latched, therefore a transient error is recorded.

Note



It is possible to have more than one error condition at one time. Therefore, when using the **IERR** command ensure that you allow for a reply containing more than one error description.

IERR Description	Comments
HANDLING ERROR	This error occurs: <ul style="list-style-type: none">■ If you request autovernier mode when the instrument is not in NORM mode.■ If you attempt to leave NORM mode with autovernier mode active.■ If you attempt to set a timing parameter outside its specification limits.
LEVEL ERROR	<ul style="list-style-type: none">■ This error occurs if you attempt to set output level parameters outside their specification limits. Refer to Chapter 2 as two output ranges are used.■ The instrument's output is not affected.
LIMIT ERROR	<ul style="list-style-type: none">■ This can only occur if limited output mode is active.■ This error occurs if you attempt to set output level parameters outside the current limit levels.■ The instrument's output is not affected.

**Syntax Error
(Bit 2)**

This error occurs when the HP 8116A cannot understand a programming message. The bit is latched until cleared by reading the status byte.

**System Failure
(Bit 3)**

This error occurs when the HP 8116A fails its self-test. You can execute a self-test using the **EST** command:

```
OUTPUT 716;"EST"   Request a self-test
WAIT 3             Allow HP 8116A to execute self-test
A = SPOLL(716)    Read status byte in order to get result
```

The bit is latched until cleared by reading the status byte.

**Autovernier in Progress
(Bit 4)**

This bit is set during an autovernier.

**Sweep in Progress
(Bit 5)**

This bit is set during an output frequency sweep.

**Service Request
(Bit 6)**

This bit indicates that a service request has occurred. The bit is latched until cleared by reading the status byte.

**Buffer not Empty
(Bit 7)**

This bit is set when there is data in the HP 8116A's input buffer. You can monitor this bit to determine if the instrument has finished interpreting a long programming message.

HP-IB Universal Commands

The HP 8116A supports the following HP-IB Universal commands:

Note



These are HP-IB commands, NOT instrument programming commands. They are not used in programming messages. If you require more information on the HP-IB protocol and hardware refer to “General” for a list of references.

HP-IB Mnemonic	Description	BASIC 5.0/5.1 equivalent
DCL	Device Clear	CLEAR 7
SDC	Selected Device Clear	CLEAR 716
LLO	Local Lockout	LOCAL LOCKOUT 7
GTL	Go to Local	LOCAL 716 / LOCAL 7
GET	Group Execute Trigger	TRIGGER 716 / TRIGGER 7
UNL	Unlisten	SEND 716;UNL
UNT	Untalk	SEND 716;UNT
SPE	Serial Poll Enable	SPOLL(716)
SPD	Serial Poll Disable	

DCL An HP-IB DCL command causes the HP 8116A to load its standard parameter set. The instrument remains in its current mode (local or remote).

SDC An HP-IB SDC command causes the HP 8116A to load its standard parameter set and enter remote mode.

GET An HP-IB GET command simulates an external trigger to the HP 8116A in TRIG, E.BUR and E.SWP modes.

Programming Examples

Introduction

The following examples are an introduction to programming the HP 8116A using BASIC 5.0/5.1 for the HP 9000 Series 200/300 controllers. The examples cover the following subjects:

- Testing communication with the HP 8116A.
- Performing the instrument's self-test.
- Using the Buffer not Empty flag.
- Using the autovernier.

Note



In the examples it is not strictly necessary to put the HP 8116A into remote mode using the REMOTE 716 command because:

- The CLEAR 716 statement used to initialise the instrument also selects remote mode.
- The OUTPUT statement itself selects remote mode.

However, the REMOTE statement is included for completeness.

Testing communication

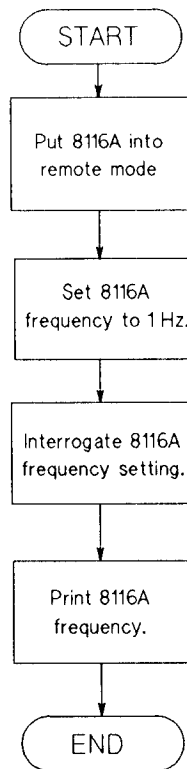

Programming applications should include an initial check that the HP 8116A is communicating correctly. A suitable quick check is to set a parameter to a particular value and then read it back, as illustrated by the flow chart and program example given here.

```

1      !                               Comments:
10     Adr=716                         !Device address of the HP 8116A
20     CLEAR Adr                       !Initialize Interface, set HP 8116A to
30     CLEAR SCREEN                    !Standard setting, and clear screen
40     A=SPOLL(Adr)                    !Clear the Status Byte
50     !
60     !           Program to check TALK/LISTEN FUNCTION
70     !
80     !                               (Visual Indicators)
90     !
100    REMOTE Adr                      !Enable Remote Control of HP 8116A
110    !                               (RMT LED on)
120    !
140    OUTPUT Adr;"FRQ 1 HZ"          !Set HP8116A frequency to 1 Hz
150    !                               (RMT and ADS LED's on,
160    !                               FRQ key LED on,
170    !                               '1.00 Hz' displayed)
180    OUTPUT Adr;"IFRQ"              !"Interrogate Frequency" command
200    !
210    ENTER Adr;A$                   !Input data from HP 8116A
220    !
250    PRINT A$                        !Print on screen
260    !                               (Printout " FRQ 1.00 HZ")
270    !
290    LOCAL Adr                      !Return HP 8116A to local operating mode
300    !
320    END

```

Performing self-test

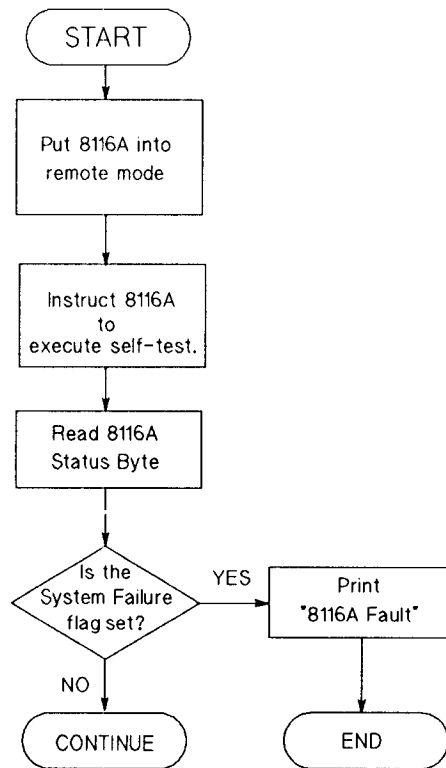

The HP 8116A RAM/Hardware self-test can be initiated via the HP-IB using the **EST** message. If a fault is detected, the HP 8116A sets the System Failure and Service Request bits in its HP-IB Status Byte. Refer to “Error, Fault and Status Reporting” in Chapter 6 for more information on the Status Byte.

```

1      !                               Comments:
10     ADR=716                          !Device address of the HP 8116A
20     CLEAR ADR                         !Initialize Interface, set HP 8116A to
25     !                                 !Standard setting and remote mode
30     CLEAR SCREEN                       !
40     A=SPOLL(ADR)                       !Clear the Status Byte
50     !
60     !           Program to check RAM and HARDWARE
70     !
80     !                                 (Visual Indicators)
100    REMOTE ADR                         !Enable Remote Control of HP 8116A
110    !                                 (RMT LED on)
140    OUTPUT ADR;"EST"                   !"Execute Self Test" command
150    !                                 (RMT and ADS LED's on)
160    WAIT 3                             !Time for HP 8116A internal processing
170    !
180    A=SPOLL(ADR)                       !Read and clear Status Byte
190    !
210    B=BIT(A,3)                         !Read bit 3 = System Failure Flag
220    !
230    IF B=1 THEN                         !If bit 3 is set, HP 8116A has a fault
240    !
250        PRINT "HP 8116A FAULT"         !Print fault message on screen
260    !
270    END IF
280    !
290    LOCAL ADR                           !Set HP 8116A to local operating mode
300    !
310    END

```

HP 8116A Self-test

Using the Buffer Not Empty Flag

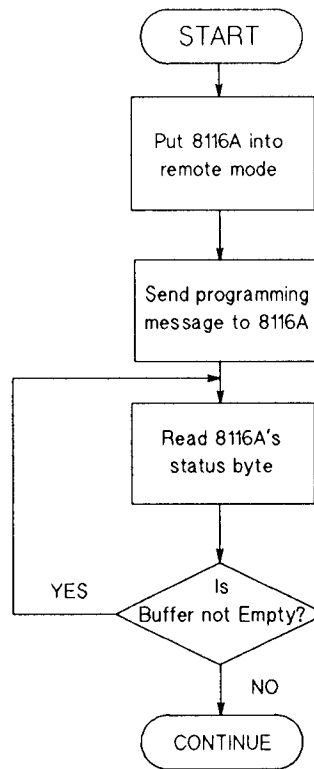

The Buffer Not Empty flag indicates that the HP 8116A is currently interpreting a programming message. You can use the flag to make the system controller wait until a message has been implemented before proceeding. This is an alternative to using the WAIT statement with a fixed delay.

```

10      !                               Comments:
20      Adr=716                          !Address of the HP 8116A
30      CLEAR Adr                         !Initialize interface, set HP 8116A to
40      !                               !standard setting and remote mode
50      CLEAR SCREEN
60      A=SPOLL(Adr)                       !Clear the status byte
60      !
70      OUTPUT Adr;"M2,T1,W2,FRQ 10 KHZ,AMP 1 V,OFS 1 V"
80      !                               !Select trigger mode with triggering on
90      !                               !positive slope, triangle signal output
100     !                               !and change frequency,amplitude and offset
110     !
130     REPEAT                             !Keep polling the HP 8116A status byte
140         A=SPOLL(716)                   !until Buffer Not Empty flag returns to
150     UNTIL BIT(A,7)=0                   !zero indicating the command message has
160     !                               !been implemented
170     !
180     LOCAL Adr                          !Return HP 8116A to local mode
190     !
200     !
210     END

```

Using the Autovernier

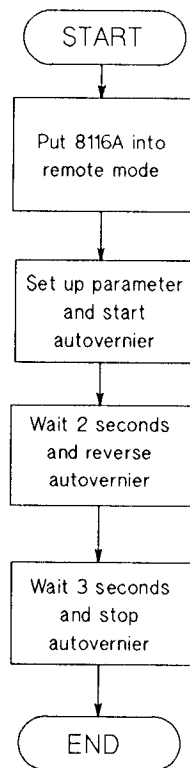

The autovernier function is fully programmable, however, the digit up/down commands will cause a syntax error if they are used without autovernier mode switched on. The example shows an autovernier over fixed time intervals. You can also monitor the Autovernier in Progress bit in the status byte to allow an autovernier to continue until the parameter limits are reached.

```

10      !                               Comments:
20      ADR=716                          !Address of the HP 8116A
30      CLEAR ADR                         !Initialize interface, set HP 8116A to
40      !                                  !standard setting and remote mode
50      CLEAR SCREEN
60      A=SPOLL(ADR)                       !Clear the status byte
70      !
80      OUTPUT ADR;"DO"                    !Enable the HP 8116A's output
90      !
100     !
110     OUTPUT ADR;"OFS 100 MV,A1,SU"      !Set offset to 100 mV and start
120     !                                  !autovernier upwards in steps of 10 mV
130     !
140     WAIT 2
150     !
160     !
170     OUTPUT ADR;"SD"                    !After 2 seconds, decrement in 10mV
180     !                                  !steps from the current offset
190     !
200     WAIT 3
210     !
220     !
230     OUTPUT ADR;"AO"                    !After another 3 seconds, stop
240     !                                  !autovernier function
250     !
260     LOCAL ADR                          !Return to local mode
270     !
280     !
290     END

```

Index

- A**
 - A0 - A1, 6-8
 - AM, 4-8
 - AMP, 4-12, 6-6
 - Autovernier
 - Operating, 4-14
 - Programming, 6-8
 - Status, 6-16

- B**
 - BUR, 4-12, 6-7

- C**
 - C0 - C1, 6-10
 - Control mode
 - AM, 4-8
 - FM, 4-8
 - Programming, 6-5
 - PWM, 4-9
 - Selecting, 4-7
 - VCO, 4-10
 - CST, 6-11
 - CT0 - CT4, 6-5

- D**
 - D0 - D1, 6-10
 - DCL, 6-17
 - DTY, 4-12, 6-6

- E**
 - Error
 - Programming, 6-15
 - reporting, 6-13
 - Syntax, 6-15
 - Timing, 6-14
 - External Trigger Controls, 4-6

- F**
 - Fault reporting, 6-13
 - FM, 4-8
 - FRQ, 4-12, 6-6

- G** GET, 6-17
GTL, 6-17

- H** H0 - H1, 6-5
HIL, 4-12, 6-6
Hold Input, 4-16
HP-IB
 Address, 6-1
 Status byte, 6-13
 Universal commands, 6-17

- I** IERR, 6-13, 6-14, 6-15

- K** Keys
 I CYCLE, 4-6
 -90°, 4-11
 AUTO, 4-14
 COMPL, 4-15
 DISABLE, 4-15
 LCL, 6-2
 LIMIT, 4-15
 MAN, 4-6
 VERNIER, 4-13

- L** L0 - L1, 6-10
LD, 6-8
LLO, 6-17
Local lockout, 6-2
Local mode, 6-2
LOL, 4-12, 6-6
LU, 6-8

- M** M1 - M8, 6-4
Marker Output, 4-16
MD, 6-8
MRK, 4-12, 6-7
MU, 6-8

- O** OFS, 4-12, 6-6
Operating, 4-1
Output mode
 Programming, 6-10
 Selecting, 4-15

- P** Parameter
 - Programming, 6-6
 - Reading, 6-9, 6-11
 - Setting, 4-12
- Power on, 4-2
- Programming, 6-1
 - Examples, 7-1
- Programming error, 6-15
- PWM, 4-9

- R** Remote mode, 6-2
- RPT, 4-12, 6-7

- S** SD, 6-8
- SDC, 6-17
- SPD, 6-17
- SPE, 6-17
- SRQ, 6-13, 6-16
- STA, 4-12, 6-7
- Standard Parameter Set, 4-3
- Status byte, 6-13
- Status reporting, 6-13
- STP, 4-12, 6-7
- SU, 6-8
- Switching on, 4-2
- SWT, 4-12, 6-7
- Syntax error, 6-15
- System Failure, 6-15

- T** T1 - T3, 6-4
- Test
 - Self-test, 4-2, 6-15
- Testing
 - Self-test, 7-4
- Timing error, 6-14
- Trigger Controls, 4-6
- Trigger mode
 - Programming, 6-4
 - Selecting, 4-4
- Trigger Output, 4-6

- U** UNL, 6-17
- UNT, 6-17

- V** VCO, 4-10

- W** W0 - W4, 6-5
Waveform
 - programming, 6-5
 - selecting, 4-11WID, 4-12, 6-6

- X** X-Output, 4-16

Testing Performance

Introduction

This chapter lists a number of test procedures designed to test the electrical performance of the HP 8116A against the Specifications and Operating Characteristics given in Chapter 2. The tests are in two groups, Performance tests which check warranted Specifications and Verification tests which verify Operating Characteristics.

Performance Tests

- Frequency
- Duty Cycle
- Pulse Width
- Amplitude & Offset
- Sine waveform
- Pulse/Squarewave waveform
- DC output

Verification Tests

- Trigger, Gate and External Width modes
- Burst modes (Opt 001)
- Frequency Modulation
- Amplitude Modulation
- Pulse Width Modulation
- Sweep modes (Opt 001)
- Autovernier and Output modes
- HP-IB programming

The tests can be used for incoming inspection, troubleshooting or preventative maintenance. Note that to prove that the instrument is within specification, only the Performance Tests have to be carried out. The test results can be recorded on a copy of the Test Records which follow the test procedures. Test results recorded at incoming inspection can be used for comparison after carrying out maintenance, repair or adjustments.

The tests must be performed with the HP 8116A in its normal operating condition, that is, with all shields, connections and the case in place.

Test Equipment

Refer to Table 1-1 and Table 1-2 for the recommended test equipment.

Test Record

Equipment Test Records are provided at the end of this chapter. Make a copy in order to record your test results.

Frequency Performance Test

Specifications

Range

1.00 mHz to 50.0 MHz

Accuracy

Frequency (FRQ)	Pulse mode or waveforms with 50% duty cycle	Waveforms with duty cycle \neq 50%
$1 \text{ mHz} \leq \text{FRQ} < 100 \text{ kHz}$	$\pm 3\% \pm 0.3 \text{ mHz}$	$\pm 3\% \pm 0.6 \text{ mHz}$
$100 \text{ kHz} \leq \text{FRQ} < 10 \text{ MHz}$	$\pm 5\%$	$\pm 10\%$
$10 \text{ MHz} \leq \text{FRQ} \leq 50 \text{ MHz}$	$\pm 5\%$	n/a

Test Setup

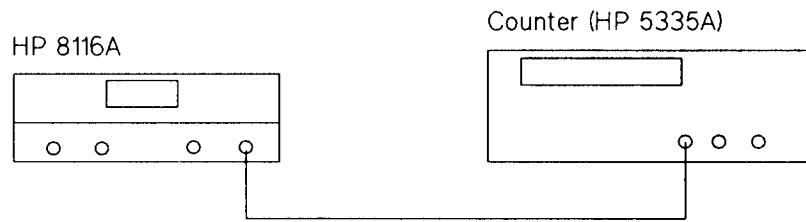

Figure 8-1. Frequency Performance Test

Equipment

- Counter (HP 5335A)
- Cable Assembly BNC
- 50 Ω Feedthrough Termination
(Required if counter input impedance \neq 50 Ω)

Procedure

1. Connect the equipment as shown in the setup figure. Use a 50 Ω feedthrough termination if you cannot select 50 Ω input impedance on the counter.
2. Set up the HP 8116A as follows:

Trigger Mode	NORM
Control Mode	Off
Waveform	Square
Complement Output	Off
DTY	50%
AMP	1 V
OFS	0 V
3. Set the counter to measure frequency.
4. Set the HP 8116A's frequency to the following values and read the actual output frequency from the counter. Record your results on a copy of the Test Record, specified limits are given here and on the Test Record.

HP 8116A setting	Counter reading
50.0 MHz	50.0000 MHz \pm 2.500 MHz
10.0 MHz	10.0000 MHz \pm 0.500 MHz
10.0 kHz	10.0000 kHz \pm 0.300 kHz
1.0 kHz	1.00000 kHz \pm 0.30 kHz

5. Set the counter to measure period.
6. Set the HP 8116A's frequency to the following values and read the actual period from the counter. Record your results on a copy of the Test Record, specified limits are given here and on the Test Record.

HP 8116A setting	Counter reading
1.00 Hz	1.00000 s \pm 0.0333 s
100 mHz	10.0000 s \pm 0.333 s

Duty Cycle Performance Test

Specifications

Frequency (FRQ)	Range and Resolution	Accuracy
$1 \text{ mHz} \leq \text{FRQ} < 1 \text{ MHz}$	10% to 90% in steps of 1%	$\pm 0.5 \text{ LSD}^*$
$1 \text{ MHz} \leq \text{FRQ} < 10 \text{ MHz}$	20% to 80% in steps of 1%	$\pm 3.0 \text{ LSD}$
$10 \text{ MHz} \leq \text{FRQ} \leq 50 \text{ MHz}$	50% fixed	$\pm 5.0 \text{ LSD, typical}$

*Least Significant Digit (only units and tens are displayed)

Test Setup

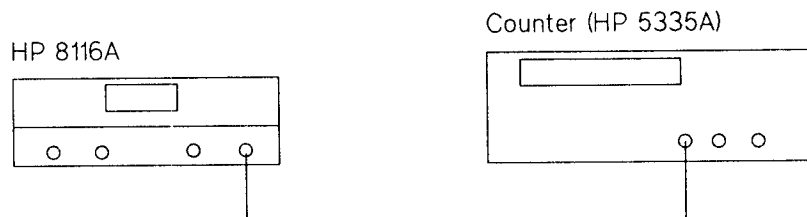

Figure 8-2. Duty Cycle Performance Test

Equipment

- Counter (HP 5335A)
- Cable Assembly BNC
- 50Ω Feedthrough Termination
(Required if counter input impedance $\neq 50 \Omega$)

Procedure

1. Connect the equipment as shown in the setup figure. Use a 50 Ω feedthrough termination if you cannot select 50 Ω input impedance on the counter.
2. Set up the HP 8116A as follows:
Trigger Mode NORM
Control Mode Off
Waveform Square
Complement Output Off
AMP 1 V
OFS 0 V
3. Set the counter to read duty cycle.
4. Set the HP 8116A's frequency and duty cycle to the values given here, and read the actual duty cycle from the counter. Record your results on a copy of the Test Record, specified limits are given here and on the Test Record.

HP 8116A frequency	HP 8116A Duty cycle	Counter reading
1 Hz	10%	9.5% to 10.5%
	50%	49.5% to 50.5%
	90%	89.5% to 90.5%
1 kHz	10%	9.5% to 10.5%
	50%	49.5% to 50.5%
	90%	89.5% to 90.5%
9.99 MHz	20%	17.0% to 23.0%
	50%	47.0% to 53.0%
	80%	77.0% to 83.0%

Pulse Width Performance Test

Specification

Range

10.0 ns to 999 ms
(Maximum = $1/\text{FRQ} - 10 \text{ ns}$)

Accuracy

$\pm 5\% \pm 2 \text{ ns}$

Test Setup

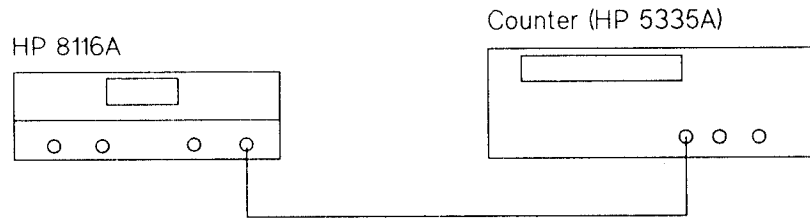

Figure 8-3. Pulse Width Performance Test - Stage 1

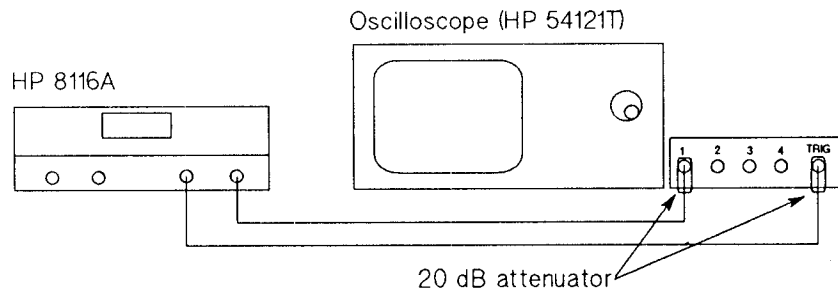

Figure 8-4. Pulse Width Performance Test - Stage 2

Equipment

- Counter (HP 5335A)
- Cable Assembly BNC (2 ×)
- Digitizing Oscilloscope (HP 54121T)
- Attenuator 20 dB, 2 W. (2 ×)
- 50 Ω Feedthrough Termination
(Required if counter input impedance $\neq 50 \Omega$)

Procedure

1. Connect the HP 8116A and counter as shown in Figure 8-3.
2. Set up the HP 8116A as follows:
Trigger Mode NORM
Control Mode Off
Waveform Pulse
FRQ 1 MHz
AMP 1 V
OFS 0 V
3. Set counter to TIME A→B, COMA f, B λ, Trig level 0 V.
4. Set the HP 8116A's frequency and pulse width to the values given here and read the actual pulse width from the counter. Record your results on a copy of the Test Record, specified limits are given here and on the Test Record.

HP 8116A Frequency	HP 8116A Width	Counter reading
1 MHz	100 ns	93 ns to 107 ns
100 kHz	1 μs	948 ns to 1052 ns
1 kHz	100 μs	95 μs to 105 μs
10 Hz	1 ms	950 μs to 1050 μs
1 Hz	500 ms	475 ms to 525 ms

5. Connect the HP 8116A and oscilloscope as shown in Figure 8-4.
6. Set up the HP 8116A as follows:
FRQ 10.0 MHz
WID 8.0 ns
7. Adjust the oscilloscope to show one cycle on the display.

Note



Pulse width is measured at 50% of pulse amplitude.

8. Verify that the pulse width is ≤ 10 ns, and record the actual pulse width on your Test Record.

Amplitude & Offset Performance Test

Specification Amplitude and offset are independently variable within the following two level windows:

Level window:	± 800 mV	± 8.00 V
Amplitude range	10.0 mV to 99.9 mV (p-p)	100 mV to 16.0 V (p-p)
Amplitude resolution	3 digits (best case 0.1 mV)	3 digits (best case 1 mV)
Amplitude accuracy	$\pm 5\%$	$\pm 5\%$
Offset range	0 to ± 795 mV	0 to ± 7.95 V
Offset resolution	3 digits (best case 0.1 mV)	3 digits (best case 1 mV)
Offset accuracy	$\pm 1\%$ of programmed value $\pm 1\%$ of amplitude ± 4 mV	$\pm 0.5\%$ of programmed value $\pm 1\%$ of amplitude ± 40 mV
Repeatability	Factor 4 better than accuracy	

Test Setup

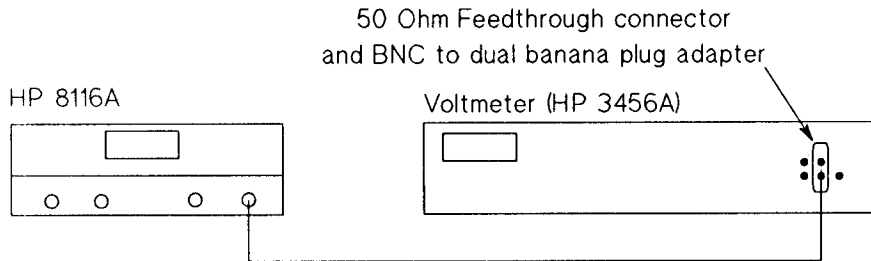

Figure 8-5. Amplitude & Offset Performance Test

- Equipment**
- Digital Voltmeter (HP 3456A)
 - Cable Assembly BNC
 - 50 Ω Feedthrough Termination (1% accuracy)
 - BNC to Dual Banana plug adapter

Procedure

1. Connect the equipment as shown in the setup figure.
2. Set up the HP 8116A as follows:

Trigger Mode	NORM
Control Mode	Off
Waveform	Sine
Complement Output	Off
FRQ	1 kHz
DTY	50%
OFS	0 V
3. Set the voltmeter to measure ac voltage (RMS).
4. Set the HP 8116A's amplitude to the values given here. For each value, vary the output waveform and read the RMS output voltage from the voltmeter. Record your results on a copy of the Test Record, specified limits are given here and on the Test Record.

HP 8116A Amplitude	HP 8116A Offset	HP 8116A Waveform	Voltmeter reading
8.00 V	0 mV	Sine	2.69 to 2.97 V
		Triangle	2.19 to 2.43 V
		Square	3.8 to 4.2 V
3.00 V	0 mV	Sine	1.008 to 1.114 V
		Triangle	0.823 to 0.909 V
		Square	1.425 to 1.575 V
1.00 V	0 mV	Sine	0.336 to 0.372 V
		Triangle	0.275 to 0.303 V
		Square	0.475 to 0.525 V
100 mV	0 mV	Sine	33.6 to 37.1 mV
		Triangle	27.4 to 30.3 mV
		Square	47.5 to 52.5 mV

5. Set the voltmeter to read dc voltage.
6. For amplitudes of 100 mV and 10 mV, vary the offset through the values given here and read the output voltage from the voltmeter. Record your results on a copy of the Test Record, specified limits are given here and on the Test Record.

HP 8116A Amplitude	HP 8116A Offset	Voltmeter reading
100 mV	7.50 V	7.421 to 7.587 V
	5.00 V	4.934 to 5.066 V
	3.00 V	2.944 to 3.056 V
	1.00 V	0.954 to 1.046 V
	100 mV	58 to 142 mV
10 mV	795 mV	783 to 807 mV
	500 mV	491 to 509 mV
	100 mV	95 to 105 mV

Sine Waveform Performance Test

Specification The following specifications apply for normal output mode and 50% duty cycle.

Total Harmonic Distortion (THD) < 1% (-40 dB), (10 Hz to 50 kHz).
This may increase by 3 dB below 10°C.

Harmonic signals < 2% (-34 dBc*)
for $50 \text{ kHz} \leq \text{FRQ} < 1 \text{ MHz}$

< 7% (-23 dBc*)
for $\text{FRQ} \geq 1 \text{ MHz}$
and amplitude < 8 V (p-p)

* dBc = dB relative to carrier (fundamental).

Test Setup

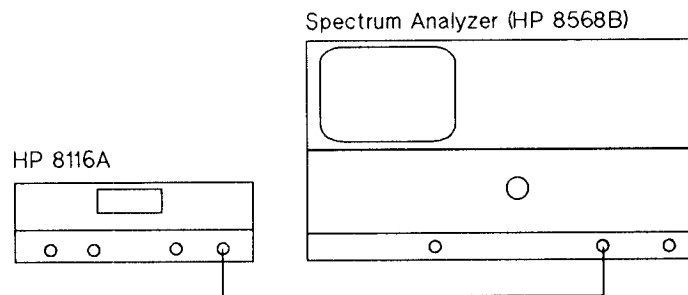

Figure 8-6. Sine Waveform Performance Test

Equipment

- HF Spectrum Analyzer (HP 8568B)
- Cable Assembly BNC
- BNC to Type N Adapter

Procedure

1. Connect the equipment as shown in the setup figure
2. Set up the HP 8116A as follows:

Trigger Mode	NORM
Control Mode	Off
Waveform	Sine
Complement Output	Off
FRQ	1 kHz
DTY	50%
AMP	8 V
OFS	0 V
3. Adjust the spectrum-analyzer frequency sweep to cover the range 500 Hz to 30 kHz.
4. Adjust the gain so that the fundamental (1 kHz) corresponds to 0 dB.
5. If necessary, adjust the frequency sweep again so that all harmonics ≥ -60 dB are shown.
6. Calculate the Total Harmonic Distortion according to the following formula:

$$THD\% = 100 \times \sqrt{10^{\frac{A_1}{10}} + 10^{\frac{A_2}{10}} + 10^{\frac{A_3}{10}} + \dots}$$

Note



- A_1 = level of second harmonic in dB.
- Ignore all harmonics at levels ≤ -60 dB.

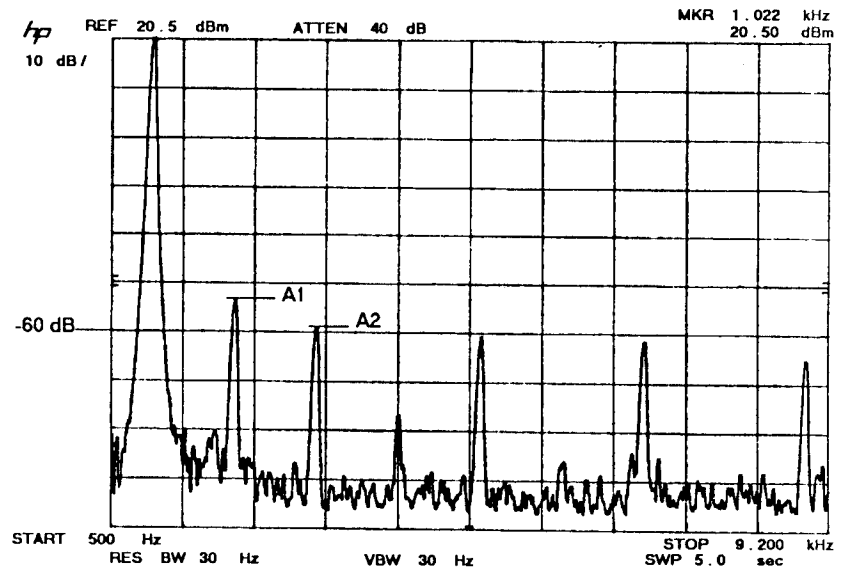

Figure 8-7. Typical Spectrum Analyzer display at 1 kHz.

7. Record the THD on the Test Record.

8. Set the HP 8116A frequency to 50 MHz.
9. Adjust the spectrum-analyzer frequency sweep to cover the range 10 MHz to 350 MHz.
10. Adjust the gain so that the fundamental (50 MHz) corresponds to 0 dB.
11. Check that no harmonics exceed -23 dB. Record the level of the worst harmonic on the Test Record.

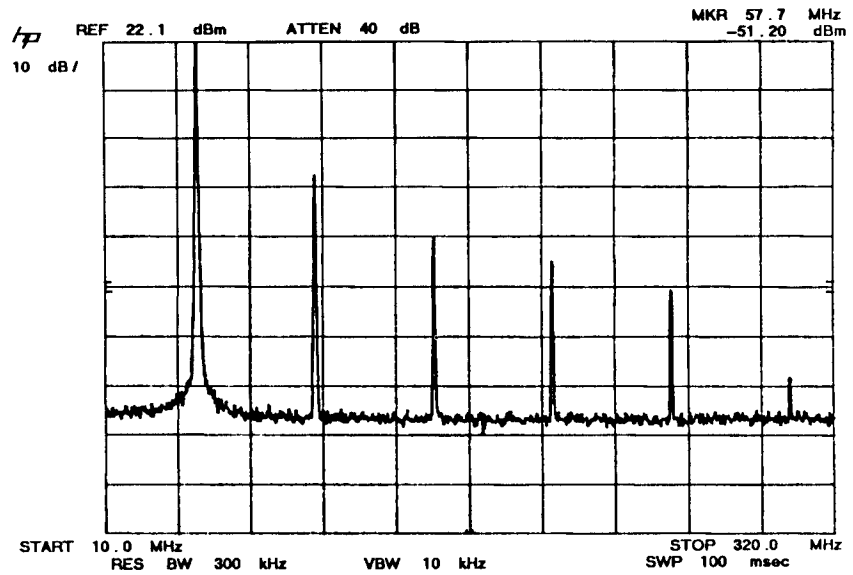

Figure 8-8. Typical Spectrum Analyzer display at 50 MHz.

Pulse/Squarewave Performance Test

Specification

Transition time < 7 ns (10% to 90% of amplitude)

Pulse perturbations < $\pm 5\%$ of amplitude ± 2 mV

Test Setup

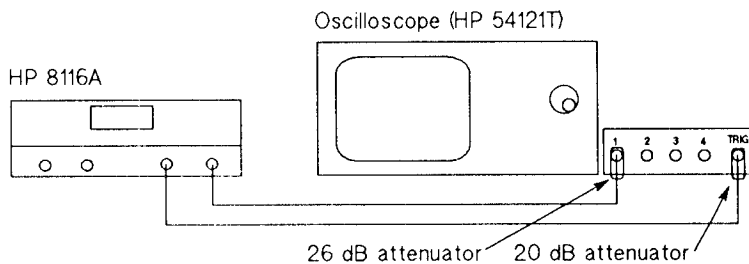

Figure 8-9. Pulse/Squarewave Performance Test

Equipment

- Digital Oscilloscope (HP 54121T)
- Cable Assembly BNC (2 x)
- Attenuator 20 dB, 2 W (2 x)
- Attenuator 6 dB, 2 W

Procedure

1. Connect the equipment as shown in the setup figure
2. Set up the HP 8116A as follows:

Trigger Mode	NORM
Control Mode	Off
Waveform	Square
Complement Output	Off
FRQ	1 MHz
DTY	50%
AMP	8 V
OFS	0 V
3. Adjust the oscilloscope so that one cycle fills the display.
4. Measure the following characteristics and record the results on the Test Record:

Note

- Transition times, rise and fall, are measured between 10% and 90% of amplitude.
- Sampling error may affect the measurement of pre- and overshoot.

Characteristic	Specification
Risetime (leading edge)	≤ 7 ns
Falltime (trailing edge)	≤ 7 ns
Preshoot	$\leq \pm 5\%$ of amplitude ± 2 mV
Overshoot/Ringing	$\leq \pm 5\%$ of amplitude ± 2 mV

DC Output Performance Test

Specification

Range	0 mV to ± 7.95 V
Resolution	3 digits, best case 1mV
Accuracy	$\pm 0.5\%$ ± 40 mV
Repeatability	Factor 4 better than accuracy

Test Setup

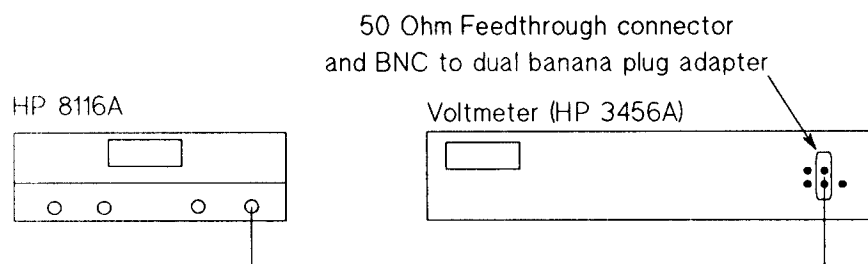

Figure 8-10. DC Output Performance Test

- Equipment**
- Digital Voltmeter (HP 3456A)
 - Cable Assembly BNC
 - 50 Ω Feedthrough Terminator.

Procedure

1. Connect the equipment as shown in the setup figure
2. Set up the HP 8116A as follows:
Trigger Mode NORM
Control Mode Off
Waveform Off
Complement Output Off
AMP 100 mV
3. With the amplitude fixed at 100 mV, vary the offset through the values given here and read the output voltage from the voltmeter. Record your results on a copy of the Test Record, specified limits are given here and on the Test Record.

HP 8116A Offset	Voltmeter reading
+7.95 V	+7.890 to 8.010 V
+5.00 V	+4.955 to 5.045 V
+2.00 V	+1.970 to 2.030 V
0.00 V	-0.020 to +0.020 V
-2.00 V	-2.030 to -1.970 V
-5.00 V	-5.045 to -4.955 V
-7.95 V	-8.010 to -7.890 V

Trigger, Gate and External Width Verification Test

Characteristics

Trigger

Minimum amplitude 500 mV (p-p)

Minimum pulse width 10 ns

Generates one output cycle.

Gate

- External signal enables output.
- First output cycle synchronous with external trigger.
- Last output cycle always completed.

External Width

In pulse waveform only, the external signal is used to determine the output pulse width.

Test Setup

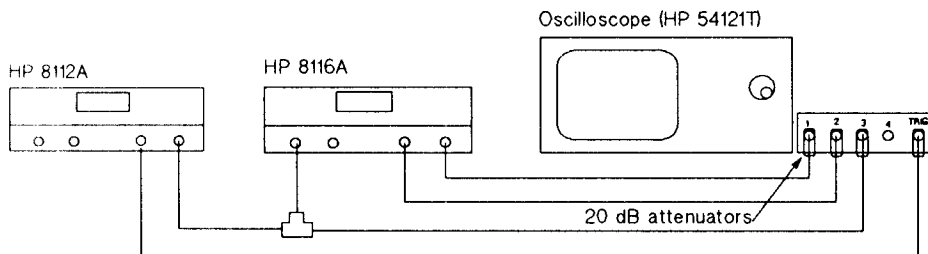

Figure 8-11. Trigger, Gate & External Width Performance Test

Equipment

- Pulse generator (HP 8112A)
- Oscilloscope (HP 54121T)
- Attenuator 20 dB, 2 W (4 ×)
- Cable Assembly BNC (5 ×)
- BNC T-connector

Procedure

1. Connect the equipment as shown in the setup figure

2. Set up the HP 8116A as follows:

Trigger Mode	TRIG
Trigger Slope	<i>f</i>
Control Mode	Off
Waveform	Sine
Complement Output	Off
FRQ	60 kHz
DTY	50%
AMP	1 V
OFS	0 V

3. Set up the external pulse generator as follows:

Pulse Width	50 μ s
Period	100 μ s
Output low level	0 V
Output high level	1 V

4. Using the oscilloscope, adjust the HP 8116A trigger level to allow triggering from the external pulse generator.

5. Verify that each external trigger pulse generates one complete output cycle as shown here:

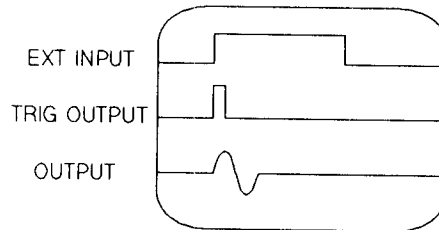

6. Set the HP 8116A to GATE trigger mode. Verify that the external signal enables output cycles and that each cycle is complete, as shown here:

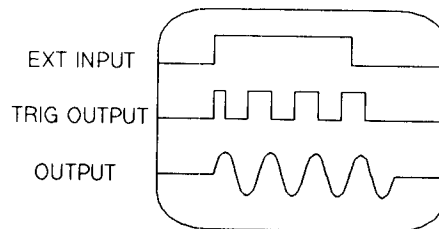

- Set the HP 8116A to E.WID trigger mode and pulse waveform. Verify that the external pulse triggers an output pulse of the same width, as shown here:

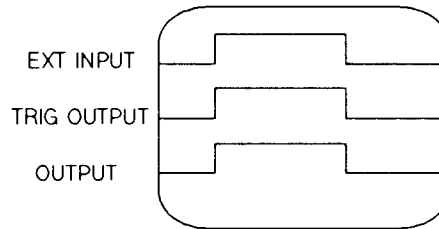

Burst Modes Verification Test (Opt 001)

- Characteristics**
- Internal burst:** Output bursts are repeatedly generated at programmable time intervals in the range 100 ns to 999 ms. This mode is not available in pulse waveform mode.
 - External burst:** An output burst is triggered by the external signal. The minimum time between burst triggers is 100 ns.

Test Setup

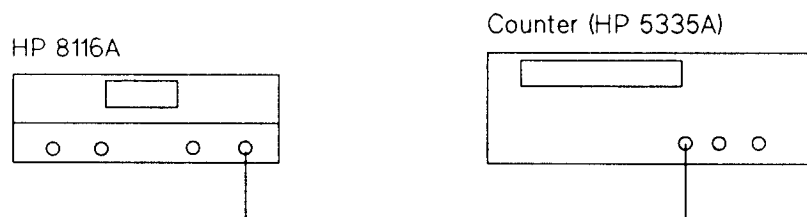

Figure 8-12. Burst Modes Verification Test

- Equipment**
- Counter (HP 5335A)
 - Cable Assembly BNC
 - 50 Ω Feedthrough Termination
(Required if counter input impedance \neq 50 Ω)

Procedure

1. Connect the equipment as shown in the setup figure. Use a 50 Ω feedthrough termination if you cannot select 50 Ω input impedance on the counter.
2. Set up the HP 8116A as follows:

Trigger Mode	E.BUR
Control Mode	Off
Waveform	Square
Complement Output	Off
FRQ	10 kHz
DTY	50%
AMP	1 V
OFS	0 V
BUR	816
3. Set the counter to **TOT A** and manual Gate mode.
4. Reset the counter and enable the gate.
5. Simulate an external trigger to the HP 8116A by pressing the **MAN** key and verify that the counter counts 816 output cycles.

Frequency Modulation Verification Test

Characteristics	Deviation	$\pm 5\%$ maximum for ± 6 V input
	Modulation bandwidth	dc to 20 kHz (FRQ < 10 MHz) dc to 3 kHz (FRQ \geq 10 MHz)

Test Setup

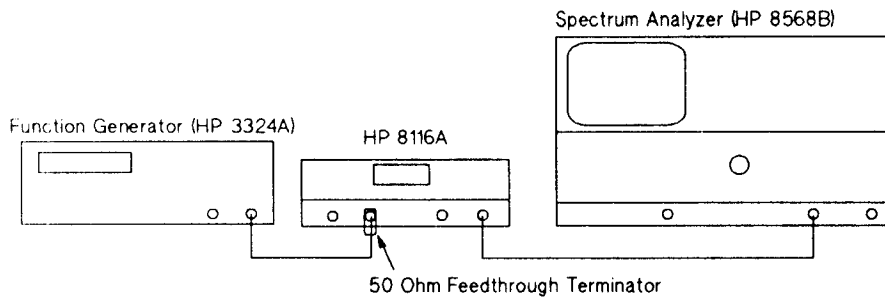

Figure 8-13. Frequency Modulation Verification Test

- Equipment**
- Pulse Generator (HP 8112A)
 - Oscilloscope (HP 54121T)
 - Cable Assembly BNC (3 ×)
 - Attenuator 20 dB, 2 W (2 ×)

Procedure

1. Connect the equipment as shown in the setup figure
2. Set up the HP 8116A as follows:

Trigger Mode	NORM
Control Mode	FM
Waveform	Square
Complement Output	Off
FRQ	1 MHz
DTY	50%
AMP	1 V
OFS	0 V
3. Set up the pulse generator as follows:

Pulse Width	50 μ s
Period	100 μ s
Output low level	-1 V
Output high level	1 V
4. Set the oscilloscope's timebase to 10 ns/div.
5. Measure the edge jitter caused by the modulation and record it on the Test Record. The jitter is typically 2 div \pm 10%.

Amplitude Modulation Verification Test

Characteristics	Modulation	100% with ± 2.5 V input DSBSC (Double Side Band Suppressed Carrier) with +2.5 V, -7.5 V input
	Modulation bandwidth	dc to 1 MHz
	Envelope distortion	< 1% for modulation depth < 90% (dc to 50 kHz and not complementary output)

Test Setup

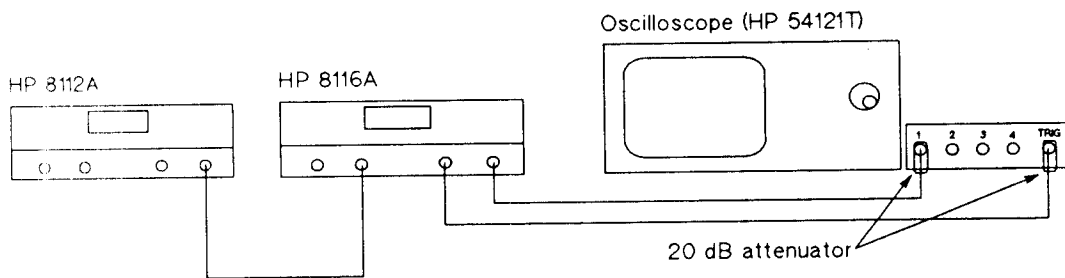

Figure 8-14. Amplitude Modulation Verification Test

- Equipment**
- Function Generator (HP 3324A)
 - Spectrum Analyzer (HP 8568B)
 - Cable Assembly BNC (2 ×)
 - Feedthrough Termination 50 Ω

Procedure

1. Connect the equipment as shown in the setup figure

2. Set up the HP 8116A as follows:

Trigger Mode	NORM
Control Mode	AM
Waveform	Sine
Complement Output	Off
FRQ	15 kHz
DTY	50%
AMP	1 V
OFS	0 V

3. Set up the function generator as follows:

Waveform	Sine
Frequency	2 kHz
Amplitude	4.5 V
Offset	0 V

4. Adjust the spectrum-analyzer frequency range to display the 15 kHz carrier, the sidebands and the harmonics of the sidebands.

5. Adjust the gain so that the carrier level is 0 dB.

6. Verify that all sideband harmonics are at least 42 dB lower than the sidebands, and record the level of the worst harmonic on the Test Record.

Procedure

1. Connect the equipment as shown in the setup figure
2. Set up the HP 8116A as follows:

Trigger Mode	NORM
Control Mode	PWM
Waveform	Pulse
Complement Output	Off
HIL	1 V
LOL	0 V

3. Set up the pulse generator as follows:

Width	500 ms
Period	999 ms
Low output level	-6 V
High output level	6 V

4. Set the HP 8116A frequency and width range to the values given in the following table, and use the oscilloscope to verify that the pulse width varies between the minimum and maximum limits.

Note

The HP 8116A displays the pulse width value corresponding to a 0 V control input signal for the chosen decade range. For example, 550 ns width indicates a pulse width range of 100 ns to 1.0 μ s. Use the range key to change the pulse width range.

HP 8116A Frequency	HP 8116A Width Range	Minimum width	Maximum width
1 MHz	55 ns	10 ns	100 ns
100 kHz	550 ns	100 ns	1.0 μ s
1 kHz	55 μ s	10 μ s	100 μ s

Sweep Modes Verification Test (Opt 001)

Characteristics For all waveforms the output signal frequency performs a logarithmic sweep between selected start and stop frequencies within the instrument's range (1 mHz to 50 MHz). The sweep time per decade is selectable between 10 ms and 500 s but restricted to intervals in the ratios 1:2:5. The sweep always starts with 0° output phase.

Test Setup

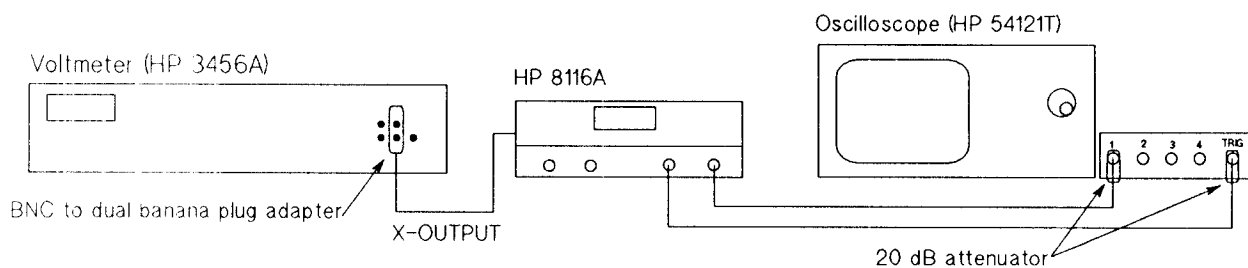

Figure 8-16. Sweep Mode Verification Test

- Equipment**
- Oscilloscope (HP 54121T)
 - Attenuator 20 dB, 2 W (2 ×)
 - Digital Voltmeter (HP 3456A)
 - Cable Assembly BNC (3 ×)

Procedure

1. Connect the equipment as shown in the setup figure
2. Set up the HP 8116A as follows:

Trigger Mode	E.SWP
Control Mode	Off
Waveform	Sine
Complement Output	Off
STA	10 kHz
STP	10 MHz
SWT	2 s/decade
MRK	1.0 MHz
AMP	1 V
OFS	0 V
3. Set the voltmeter to read DC volts.
4. Adjust the oscilloscope timebase to 50 μ s/division.
5. Verify that the HP 8116A output signal displayed on the oscilloscope is 10 kHz.
6. After pressing the **MAN** key to simulate an external trigger, confirm that:
 - a. the HP 8116A displays IP, meaning sweep in progress.
 - b. the frequency of the output signal increases.
 - c. the level of the X-OUTPUT shown on the voltmeter gradually rises from 0 V to 4.5 V during the sweep time (6 seconds).
7. At the end of the sweep adjust the oscilloscope timebase to 50 ns/division and verify that the HP 8116A output signal is 10 MHz.
8. Disconnect the X-OUTPUT from the voltmeter and connect the MARKER OUTPUT in its place.
9. Press the **MAN** key to return to the start frequency.
10. After pressing the **MAN** key again, verify that the MARKER OUTPUT switches when the marker frequency (1 MHz) is reached (4 seconds after the sweep is initiated).
11. Select I.SWP mode on the HP 8116A.
12. Verify that the sweep is running with the same parameters as before.

Autovernier and Output Mode Verification Test

Characteristics

Autovernier

In Normal mode, all parameters can be automatically incremented or decremented with selectable resolution. Pressing the **AUTO** key enables the autovernier, which can then be started by pressing the required vernier key. The autovernier is stopped by an external trigger input or by pressing the **AUTO** key again.

Output modes

- Complement** Inverts the output signal.
- Disable** Disconnects the output (default on switching on).
- Limit** Implements the present output levels as output limits.

Test Setup

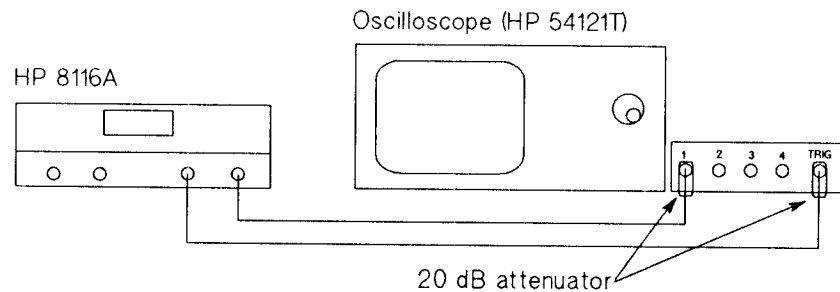

Figure 8-17. Autovernier & Output Mode Verification Test

- Equipment**
- Oscilloscope (HP 54121T)
 - Counter (HP 5335A)
 - Cable Assembly BNC (2 ×)
 - Attenuator 20 dB, 2 W (2 ×)

Procedure

1. Connect the equipment as shown in the setup figure

2. Set up the HP 8116A as follows:

Trigger Mode	NORM
Trigger Slope	Off
Control Mode	Off
Waveform	Square
Complement Output	Off
FRQ	1 kHz
HIL	1 V
LOL	0 V
DTY	10%
Limit Mode	Off

3. Set the oscilloscope timebase to 0.2 ms/division

4. Select autovernier mode on the HP 8116A by pressing the **AUTO** key.

Note



The autovernier acts on the currently selected parameter therefore make sure that DTY is the current parameter.

5. Press the upper part of the right hand vernier key and verify that the duty cycle of the HP 8116A output is incremented up to 90% in steps of 1%.

6. Press the lower part of the middle vernier key and verify that the duty cycle is decremented to 10% in steps of 10%.

7. Deselect autovernier mode by pressing the **AUTO** key.

8. Verify that the output signal is inverted by pressing the **COMPL** key.

9. Deselect the **COMPL** key.

10. Verify that the **DISABLE** key disables the output signal.

11. Re-enable the output signal.

12. Set up the HP 8116A as follows:

Trigger Mode	E.BUR
Trigger Slope	Off
Control Mode	Off
Waveform	Pulse
Complement Output	Off
FRQ	100 Hz
WID	5 μ s
BUR	123
HIL	1 V
LOL	-1 V
Limit Mode	On

13. Disconnect the oscilloscope and connect the counter in its place.

14. Set the counter to **TOT A** and enable its **GATE**.
15. Press the **MAN** key on the HP 8116A to simulate an external trigger and verify that the counter counts 123 pulses.
16. If you have Opt. 001 fitted, press the **1 CYCLE** key and confirm that the counter reading increments to 124.
17. Select the **HIL** parameter and verify that the vernier keys do not increase the **HIL** beyond the +1.0 V set previously.
18. Select the **LOL** parameter and verify that the vernier keys do not decrease the **LOL** below the -1.0 V set previously.

HP-IB Verification Test

Test Setup

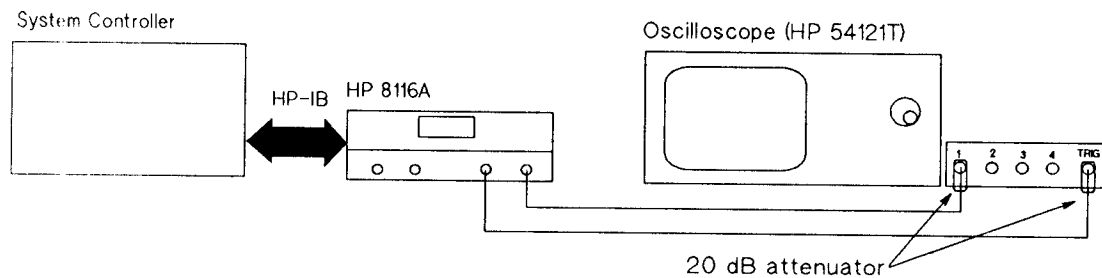

Figure 8-18. HP-IB Verification Test

- Equipment**
- Controller (HP Series 200/300)
 - Oscilloscope (HP 54121T)
 - Cable Assembly BNC (2 x)
 - HP-IB cable

Procedure

Note



All program statements assume that the HP 8116A is at HP-IB address 16 and that BASIC 5.0/5.1 is being used.

1. Connect the equipment as shown in the setup figure
2. Use the following program statements to read the HP 8116A Standard Parameter Set:

<code>DIM A\$[161]</code>	<i>Allocate controller memory to receive HP 8116A status string</i>
<code>REMOTE 716</code>	<i>Set HP 8116A to remote mode</i>
<code>CLEAR 716</code>	<i>Clear HP 8116A status and select standard parameter set</i>
<code>OUTPUT 716;"CST"</code>	<i>Request current settings from HP 8116A</i>
<code>ENTER 716;A\$</code>	<i>Read the HP 8116A settings</i>
<code>PRINT A\$</code>	<i>Display the HP 8116A settings</i>

3. Verify that the result is:

```
M1,CTO,T1,W1,HO,AO,LO,CO,D1,BUR 0001 #,RPT 100 MS,  
STA 1.00 KHZ,STP 100 KHZ,SWT 50.0 MS,MRK 1.00 KHZ,  
FRQ 1.00 KHZ,DTY 50 %,WID 500 US,HIL 0.50 V,LOL -0.50 V
```

Note



If you do not have Opt 001 fitted, the Opt 001 parameters will not be part of the status string.

4. Use the following program statements to change some instrument settings and then re-read the current settings:

<code>DIM B\$[161]</code>	<i>Allocate controller memory to receive second status string</i>
<code>OUTPUT 716;"FRQ 10 KHZ, DTY 10 %, W3,HIL 1.5 V, DO"</code>	<i>Change settings</i>
<code>OUTPUT 716;"CST"</code>	<i>Request current settings from HP 8116A</i>
<code>ENTER 716;B\$</code>	<i>Read the HP 8116A settings</i>
<code>PRINT B\$</code>	<i>Display the HP 8116A settings</i>

5. Verify that the settings are the same as before, except for the following:

```
FRQ 10.0 KHZ  
DTY 10 %  
HIL 1.50 V  
W3  
DO
```

6. Using the oscilloscope confirm that the HP 8116A output has the following form:

Waveform	Square
FRQ	10 kHz
DTY	10%
HIL	1.5 V
LOL	-0.5 V

PERFORMANCE TEST RECORD: Hewlett-Packard 8116A 50 MHz Pulse/Function Generator

Serial No: _____ Report No: _____ Date: _____

Test Facility :

Test Conditions :

Installed Options : _____

Ambient Temperature : _____ °C

Relative Humidity : _____ %

Line Frequency : _____ Hz

Special Notes :

Serial No: _____ Report No: _____ Date: _____

**Test Equipment
Used :**

Description	Model No.	Serial No.	Trace No.	Cal.Due Date
Counter				
Oscilloscope				
Digital Voltmeter				
Spectrum Analyzer				
Pulse Generator				
Function Generator				
Controller				

Serial No: _____ Report No: _____ Date: _____

Frequency

Frequency	Minimum	MEASURED	Maximum	Uncertainty
50.0 MHz	47.5 MHz		52.5 MHz	
10.0 MHz	9.5 MHz		10.5 MHz	
10.0 kHz	9.7 kHz		10.3 kHz	
1.00 kHz	0.97 kHz		1.03 kHz	
1.00 Hz	0.967 s		1.033 s	
100 mHz	9.66 s		10.33 s	

Duty Cycle

Frequency	Duty cycle	Minimum	MEASURED	Maximum	Uncertainty
1 Hz	10%	9.5%		10.5%	
	50%	49.5%		50.5%	
	90%	89.5%		90.5%	
1 kHz	10%	9.5%		10.5%	
	50%	49.5%		50.5%	
	90%	89.5%		90.5%	
9.99 MHz	20%	17.0%		23.0%	
	50%	47.0%		53.0%	
	80%	77.0%		83.0%	

Pulse Width

Width	Minimum	MEASURED	Maximum	Uncertainty
100 ns	93 ns		107 ns	
1 μ s	948 ns		1052 ns	
100 μ s	95 μ s		105 μ s	
1 ms	950 μ s		1050 μ s	
500 ms	475 ms		525 ms	
8 ns			10 ns	

Serial No: _____ Report No: _____ Date: _____

Amplitude & Offset

Amplitude

Amplitude	Waveform	Minimum	MEASURED	Maximum	Uncertainty
8.00 V	Sine	2.69 V		2.97 V	
	Triangle	2.19 V		2.43 V	
	Square	3.8 V		4.2 V	
3.00 V	Sine	1.008 V		1.114 V	
	Triangle	0.823 V		0.909 V	
	Square	1.425 V		1.575 V	
1.00 V	Sine	0.336 V		0.372 V	
	Triangle	0.275 V		0.303 V	
	Square	0.475 V		0.525 V	
100 mV	Sine	33.6 mV		37.1 mV	
	Triangle	27.4 mV		30.3 mV	
	Square	47.5 mV		52.5 mV	

Offset

Amplitude	Offset	Minimum	MEASURED	Maximum	Uncertainty
100 mV	7.50 V	7.421 V		7.587 V	
	5.00 V	4.934 V		5.066 V	
	3.00 V	2.944 V		3.056 V	
	1.00 V	0.954 V		1.046 V	
	100 mV	58 mV		142 mV	
10 mV	795 mV	783 mV		807 mV	
	500 mV	491 mV		509 mV	
	100 mV	95 mV		105 mV	

Serial No: _____ Report No: _____ Date: _____

Sine Waveform

THD at 1 kHz Measured: _____ ± _____
 (Specified ≤1%)

Worst Harmonic at 50 MHz Measured: _____ ± _____
 (Specified ≤-23 dB relative to fundamental)

Pulse/Squarewave Waveform

Characteristic	Specification	MEASURED	Uncertainty
Risetime (leading edge)	≤7 ns		
Falltime (trailing edge)	≤7 ns		
Preshoot	≤±5% of amplitude ± 2 mV		
Overshoot/Ringing	≤±5% of amplitude ± 2 mV		

DC output

Offset	Minimum	MEASURED	Maximum	Uncertainty
+7.95 V	+7.890 V		8.010 V	
+5.00 V	+4.955 V		5.045 V	
+2.00 V	+1.970 V		2.030 V	
0.00 V	-0.020 V		+0.020 V	
-2.00 V	-2.030 V		-1.970 V	
-5.00 V	-5.045 V		-4.955 V	
-7.95 V	-8.010 V		-7.890 V	

Serial No: _____ Report No: _____ Date: _____

Trigger, Gate and External Width modes

Trigger Positive trigger initiates one complete output cycle: YES/NO

Gate Positive gate enables output cycles, last cycle completed: YES/NO

External Width Positive pulse enables output pulse of same length: YES/NO

Burst modes (Opt 001) Number of output cycles = set burst number: YES/NO

Frequency Modulation Measured Jitter:

Amplitude Modulation

Worst Sideband Harmonic Measured:
(Typically ≤ -42 dB relative to sideband)

Serial No: _____ Report No: _____ Date: _____

Pulse Width Modulation

Width Range	Minimum and Maximum achieved
10 ns to 100 ns	YES/NO
100 ns to 1.00 μ s	YES/NO
10 μ s to 100 μ s	YES/NO

Sweep modes (Opt 001)

Start frequency = 10 kHz:	YES/NO
IP displayed during sweep:	YES/NO
X-OUTPUT increases 0 V to 4.5 V during sweep:	YES/NO
Sweep duration = 6 s:	YES/NO
Stop frequency = 10 MHz:	YES/NO
MARKER OUTPUT functioning:	YES/NO
Internal sweep functioning:	YES/NO

Autovernier and Output modes

Autovernier functioning:	YES/NO
Complement output mode functioning:	YES/NO
MAN key functioning:	YES/NO
1 CYCLE key functioning (Opt 001 only):	YES/NO
Limited output mode functioning:	YES/NO

HP-IB programming

HP-IB functioning:	YES/NO
--------------------	--------

Adjustment Procedures

Safety Considerations

Warning



Dangerous voltages, capable of causing serious personal injury, are present in this instrument. Use extreme caution when handling, testing and adjusting.

The adjustments described in this chapter are performed with the instrument switched on and its protective covers removed. Therefore, the adjustments *must* only be carried out by a skilled person, who is aware of the hazards involved, and in the presence of another person who is capable of rendering first aid and resuscitation.

Capacitors inside the instrument may still be charged after the instrument has been disconnected from its external power supply.

Any disconnection of the protective ground connection, inside or outside the instrument, is prohibited, as this is likely to make the instrument dangerous.

Introduction

This chapter describes the adjustment procedures which return the HP 8116A to peak operating condition after repairs are completed. The procedures cover:

- Power Supply & Preliminary Adjustments
- Overshoot & Transition Time Adjustment
- Voltage Controlled Oscillator Adjustment
- Width Adjustment
- Shaper Adjustment
- Offset Adjustment
- Amplitude Modulator Adjustment

Note



Always allow the HP 8116A to warm up for at least 1 hour before starting any adjustment procedures.

The Power Supply and Preliminary adjustment procedure must *always* be carried out after any repairs. If any re-adjustment is required during this procedure then all the remaining procedures must be carried out. If no re-adjustment is required during the

Power Supply and Preliminary adjustment procedure then only those procedures which the repair could affect need to be carried out.

Always carry out an adjustment procedure completely and in the order in which it is presented.

Some of the adjustment procedures may require components to be changed. These components are summarised in Table 9-1.

Warning



Do not change a component while power is connected to the instrument.

Figure 9-8 and Figure 9-9 at the end of the chapter show the locations of all the adjustment points in the instrument.

Table 9-1. Adjustment Procedures - Changeable Components

Procedure	Reference	Range	Description
Overshoot/ Transition	A1C530	Jumper or 1 pF	Jumper increases overshoot
	A1 C525	1.5 pF – 15 pF	Decreasing the value increases transition time
VCO	A1R220/223	1.5 kΩ – 4.02 kΩ	Increasing the value increases amplitude flatness
Width	A1R309	1 Ω – 100 Ω	Increasing the value decreases minimum width
	A1R157	4.5 kΩ – 5.56 kΩ	Increasing the value decreases width in PWM
Shaper	A1R439	7.5 kΩ – open	Increasing the value increases offset in normal output and decreases offset in complement output modes
	A1R428	10 kΩ – open	Decreases 2nd harmonic at 1 V amplitude (Increasing the value decreases negative offset)

Test Equipment

Refer to Table 1-1 and Table 1-2 for the recommended test equipment.

Power Supply & Preliminary Adjustments

Note



If any adjustments are required during this procedure, *all* adjustment procedures must be performed subsequently.

If the HP 8116A is very badly out of adjustment, turn A1R413 fully clockwise and all other adjustment potentiometers to their mid position. Then carry out *all* the adjustment procedures.

Equipment

- Digital Voltmeter (HP 3456A)
- Oscilloscope (HP 54121T)
- Attenuator 20 dB (3 ×)

Procedure

Power Supplies

1. Put the HP 8116A into its servicing position by following the instructions in “Preparing the HP 8116A for servicing” in Chapter 10.1.
2. Connect the DVM low terminal to the ground testpoint on board A1.
3. Test the supply voltages and, if necessary, make adjustments to achieve the levels given here:

Testpoint	Adjust	Result
A1+15 V	A1R24	+15.000 V ±15 mV
A1-5.2 V	A1R12	-5.250 V ±10 mV
A1+5.0 V	-	+5.050 V ±50 mV
A3+5.0 V	-	+5.150 V ±50 mV
A1+24 V	A1R18	+24.000 V ±50 mV
A1-24 V	A1R19	-24.000 V ±50 mV
A1-15 V	A1R25	-15.000 V ±15 mV

4. Disconnect the DVM.

Square High Amplitude & Offset

5. Set up the HP 8116A as follows:

Trigger Mode	NORM
Control Mode	Off
Waveform	Square
Complement Output	Off
Disable Output	On
FRQ	100 kHz
DTY	50%
AMP	16 V
OFS	0 V

6. Connect the HP 8116A's main output to the oscilloscope via 40 dB attenuation, then set the oscilloscope channel's attenuation-factor to 100 and its offset to 0 V.
7. Connect the HP 8116A's trigger output to the oscilloscope's trigger input via 20 dB attenuation.
8. Enable the HP 8116A's output.
9. Adjust the oscilloscope for 2 V/div vertically and 2 μ s/div.
10. Adjust A1R410 (amplitude) and A1R425 (offset) to achieve an output amplitude of 16 V (8 divisions) symmetrical about 0 V.

Triangle High Amplitude & Offset

11. Set the HP 8116A waveform to triangle.
12. Adjust A1R227 (amplitude) and A1R407 (balance) to achieve an output amplitude of 16 V (8 divisions) symmetrical about 0 V.

Sine High Amplitude & Offset

13. Set the HP 8116A waveform to sine.
14. Adjust A1R418 (amplitude) and A1R402 (balance) to achieve an output amplitude of 16 V (8 divisions) symmetrical about 0 V.
15. Adjust A1R409 to give the best sinewave signal.

Square Low Amplitude & Offset

16. Set up the HP 8116A as follows:

Waveform	Square
AMP	1 V
OFS	0 V

17. Re-connect the HP 8116A's main output to the oscilloscope using only 20 dB attenuation and set the channel attenuation-factor to 20.
18. Adjust the oscilloscope to 200 mV/div. Using Delta V mode set Marker 1 to -500 mV and Marker 2 to +500 mV.
19. Turn A1R450 fully anti-clockwise.

20. Adjust A1R450 and A1R416 to achieve an output amplitude of 1 V (5 divisions) symmetrical about 0 V.

Sine Low Amplitude

21. Set the HP 8116A waveform to sine.
22. Turn A1R445 fully clockwise and then adjust it to achieve an output amplitude of 1 V (5 divisions).

Low Frequency Pulse Performance

23. Set up the HP 8116A as follows:

Waveform	Square
FRQ	1 kHz

24. Set the oscilloscope timebase to 200 μ s/div.
25. Adjust A1R515 to achieve the best squarewave signal.

Overshoot & Transition Time Adjustment

- Equipment**
- Oscilloscope (HP 54121T)
 - Attenuator 20 dB (3 ×)

Procedure

1. Set up the HP 8116A as follows:

Trigger Mode	NORM
Control Mode	Off
Waveform	Triangle
Complement Output	Off
Disable Output	On
FRQ	10 MHz
DTY	50%
AMP	1.6 V
OFS	0 V

2. Connect the HP 8116A's main output to the oscilloscope via 20 dB attenuation, then set the channel attenuation-factor to 20 and the offset to 0 V.
3. Connect the HP 8116A's trigger output to the oscilloscope's trigger input via 20 dB attenuation.
4. Set the oscilloscope to 200 mV/div and 20 ns/div.
5. Enable the HP 8116A's output.
6. Adjust A1R535 to give a linear, triangular waveform.
7. Add a second 20 dB attenuator to the oscilloscope input which you are using and set the channel attenuation-factor to 100.
8. Set up the HP 8116A as follows:

Waveform	Square
AMP	16 V

9. Set the oscilloscope to 5 V/div.
10. Adjust A1C529, in normal and complement output modes, to achieve overshoot < 4%.
11. Set the HP 8116A output amplitude to 1 V.
12. Remove the second 20 dB attenuator from the oscilloscope input and set the channel attenuation-factor to 10.
13. Set the oscilloscope to 200 mV/div.
14. Adjust A1R535, in normal and complement output modes, to achieve overshoot < 4%.
15. Add the second 20 dB attenuator back to the oscilloscope input and set the channel attenuation-factor to 100.

16. Set the HP 8116A amplitude to 16 V.
17. Re-adjust A1R535 to achieve overshoot < 4%.
18. Set the HP 8116A output to 1 V.
19. Remove the second 20 dB attenuator from the oscilloscope input and set the channel attenuation-factor to 10.
20. Check that the transition times are < 6.6 ns in both normal and complement output modes. Transition time is measured between 10% and 90% of amplitude.
21. Set the HP 8116A output amplitude to 999 mV
22. Check that the transition times are < 6.6 ns in both normal and complement output modes.
23. Add a 6 dB attenuator to the oscilloscope input and set the channel attenuation-factor to 20.
24. Set up the HP 8116A as follows:

AMP	1 V
OFS	7.5 V
25. Set the oscilloscope channel-offset to 7.5 V and select averaged display mode with 8 averages.
26. Check that the transition times are < 6.6 ns in both normal and complement output modes.

Note



Transition times can be reduced by increasing the overshoot. If it is impossible to achieve the specifications for both these parameters, change the values of A1C525 and A1C530. Refer to Table 9-1.

Voltage Controlled Oscillator Adjustment

- Equipment**
- Counter (HP5335A)
 - Oscilloscope (HP 54121T)
 - Spectrum Analyzer (HP 8568B)

Procedure

Frequency & Duty Cycle (100 Hz - 999 kHz)

1. Set up the HP 8116A as follows:

Trigger Mode	NORM
Control Mode	Off
Waveform	Triangle
Complement Output	Off
Disable Output	Off
DTY	50%
AMP	999 mV
OFS	0 V

2. Set the counter to **TIME A→B, COMA f , B λ , Trig level 0 V**.
3. Set the counter input impedance to 50 Ω . If this is not possible, fit a 50 Ω feedthrough terminator to the counter input.
4. Connect the HP 8116A's trigger output to the counter.
5. Set the HP 8116A frequency to 1 kHz.
6. Adjust A2R22 until the measured time is 500 $\mu\text{s} \pm 0.5 \mu\text{s}$.
7. Set the HP 8116A frequency to 9.99 kHz.
8. Adjust A2R24 until the measured time is 50.05 $\mu\text{s} \pm 0.05 \mu\text{s}$.
9. Repeat the previous 4 steps until both specifications are achieved.
10. Set the counter trigger-slopes to **A λ , B f** .
11. Set the HP 8116A frequency to 1 kHz.
12. Adjust A2R25 until the measured time is 500 $\mu\text{s} \pm 0.5 \mu\text{s}$.
13. Set the HP 8116A frequency to 9.99 kHz.
14. Adjust A2R27 until the measured time is 50.05 $\mu\text{s} \pm 0.05 \mu\text{s}$.
15. Repeat the previous 4 steps until both specifications are achieved.

Frequency (1 MHz - 9.99 MHz)

16. Set the counter to measure frequency.
17. Set the counter trigger-slopes to **A f , B λ** .

18. Set the HP 8116A frequency to 9.99 MHz.
19. Adjust A1C204 until the measured frequency is 9.99 MHz \pm 0.5 MHz.
20. Set the HP 8116A frequency to 1.00 MHz.
21. Adjust A1C204 until the measured frequency is 1.00 MHz \pm 0.05 MHz.
22. Repeat the previous 4 steps until both specifications are achieved.

Flatness

23. Set the HP 8116A frequency to 2.99 MHz.
24. Connect the HP 8116A's main output to the oscilloscope via a 6 dB attenuator and set the channel attenuation-factor to 2.
25. Connect the HP 8116A's trigger output to the oscilloscope's trigger input via a 20 dB attenuator.
26. Set the oscilloscope to 160 mV/div and 100 ns/div.
27. Record the amplitude of the output signal.
28. Set the HP 8116A frequency to 9.99 MHz.
29. Check that the output amplitude has decreased by between 2% and 4% of the amplitude at 2.99 MHz. If not, you must change the values of both A1R220 and A1R223 (both must have the same value). Refer to Table 9-1.

High Frequency and Flatness (10 MHz - 50 MHz)

30. Set the HP 8116A frequency to 10 MHz.
31. Connect the HP 8116A's trigger output back to the counter.
32. Adjust A2R17 until the measured frequency is 10.00 MHz \pm 0.03 MHz.
33. Re-connect the HP 8116A's trigger output to the oscilloscope's trigger input.
34. Set the HP 8116A frequency to 2 MHz
35. Use the oscilloscope's Δ V markers to mark the current amplitude levels, or record them by hand.
36. Set the HP 8116A frequency to 50 MHz.
37. Set the oscilloscope timebase to 20 ns/div.
38. Adjust A1R221 and A1R224 to achieve a symmetrical output signal, as shown in Figure 9-1, and a measured frequency of 50.0 MHz \pm 1.0 MHz. (You will have to connect the HP 8116A's trigger output to the counter to measure the frequency).

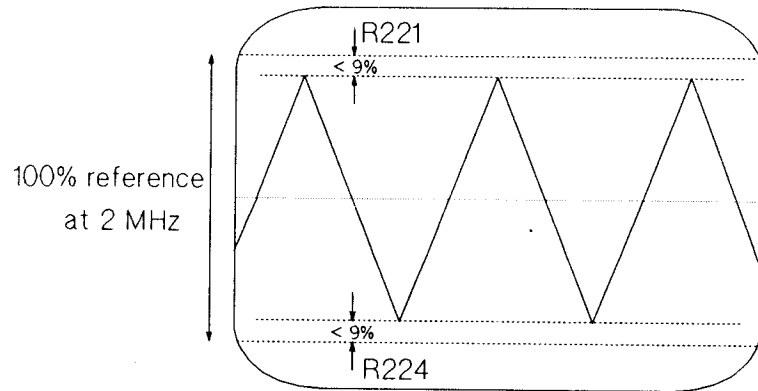

Figure 9-1. HF symmetry adjustment

39. Connect the HP 8116A's main output to the spectrum analyzer.
40. Adjust the analyzer to show the fundamental, at 0 dB, and at least the first two harmonics.
41. Re-adjust A1R221 and A1R224 for minimum 2nd harmonic distortion.
42. Switch on complement-output mode on the HP 8116A and re-adjust A1R221 for minimum 2nd harmonic distortion.
43. Switch off complement-output mode on the HP 8116A.
44. Repeat the previous three steps until you achieve the best compromise between normal and complement outputs.
45. Set the HP 8116A frequency to 42 MHz.
46. Check that the frequency measured by the counter is < 43.5 MHz.
47. Connect the HP 8116A's main output to the oscilloscope, and the HP 8116A's trigger output to the oscilloscope's trigger input.
48. Check that the amplitude remains within 20% of its value at 2 MHz throughout the frequency range 40 MHz to 50 MHz.
49. Set up the HP 8116A as follows:

Waveform	Square
FRQ	50 MHz
50. Adjust A1R130 to achieve approximately 50% duty cycle.(Toggle complement output on and off and obtain the best compromise).

Low Frequency (1 mHz - 99.9 Hz)

51. Set up the HP 8116A as follows:

Waveform	Square
FRQ	99.9 Hz
DTY	50%
AMP	1 V
OFS	0 V

52. Connect the HP 8116A's trigger output to the counter.

53. Adjust A2R18 until the measured frequency is 99.9 Hz \pm 0.1 Hz.

54. Set the HP 8116A frequency to 9.99 Hz.

55. Adjust A2R2 until the measured frequency is 9.99 Hz \pm 0.025 Hz

56. Switch the counter to measure duty cycle.

Note



If the counter you are using does not measure duty cycle directly, measure the on-time and off-time of the output signal and calculate the duty cycle.

57. Adjust A2R4 until the duty cycle is 50% \pm 0.2.

58. Repeat the previous 2 adjustments until the best compromise is obtained.

Width Adjustment

- Equipment**
- Counter (HP5335A)
 - Oscilloscope (HP 54121T)

Procedure

1. Set up the HP 8116A as follows:

Trigger Mode	NORM
Control Mode	Off
Waveform	Pulse
Complement Output	Off
Disable Output	Off
FRQ	900 Hz
AMP	1 V
OFS	0 V

2. Set the counter to **TIME A** \rightarrow **B**, **COMA** f , **B** λ , **Trig level** 0 V.

3. Set the counter input impedance to 50 Ω . If this is not possible, fit a 50 Ω feedthrough terminator to the counter input.

4. Connect the HP 8116A's main output to the counter.

5. Set the HP 8116A width parameter to 100 μ s.

6. Adjust A2R32 until the measured time is $102 \mu\text{s} \pm 1 \mu\text{s}$.
7. Set the HP 8116A width parameter to $999 \mu\text{s}$.
8. Adjust A1R304 until the measured time is $1020 \mu\text{s} \pm 10 \mu\text{s}$.
9. Repeat the previous 4 steps until both specifications are achieved.
10. Set the HP 8116A width parameter to $400 \mu\text{s}$.
11. Check that the measured time $> 386 \mu\text{s}$. If not, start this procedure again.
12. Set up the HP 8116A as follows:

WID	99.9 ns
FRQ	100 kHz
13. Adjust A2R31 until the measured time is $100 \text{ ns} \pm 1 \text{ ns}$.
14. Set up the HP 8116A as follows:

WID	8 ns
FRQ	10 MHz
15. Connect the HP 8116A's main output to the oscilloscope via a 20 dB attenuator, then set the channel attenuation-factor to 10.
16. Connect the HP 8116A's trigger output to the oscilloscope's trigger input using a 20 dB attenuator.
17. Adjust the oscilloscope to display a single output pulse.
18. Measure the pulse width (at 50% of amplitude) and check that $6.7 \text{ ns} < \text{width} < 9.5 \text{ ns}$. If not, change the value of R309 (Refer to Table 9-1).
19. Set up the HP 8116A as follows:

Trigger Mode	NORM
Control Mode	PWM
Waveform	Pulse
Complement Output	Off
Disable Output	Off
FRQ	1 kHz
WID	$550 \mu\text{s}$
AMP	1 V
OFS	0 V
20. Connect the HP 8116A's main output to the counter.
21. Check that the measured width is $550 \mu\text{s} \pm 30 \mu\text{s}$. If not, you must change the value of A1R157 (Refer to Table 9-1).

Shaper Adjustments

- Equipment**
- Digital Voltmeter (HP 3456A)
 - Spectrum Analyzer (HP 8568B)
 - Low pass filter (Refer to Figure 9-2)
(Only required if DVM does not have built-in 5 Hz low-pass input filter.)

- Procedure**
1. If you have not already done so, turn A1R413 fully clockwise.

Square amplitude

2. Set up the HP 8116A as follows:

Trigger Mode	NORM
Control Mode	Off
Waveform	Square
Complement Output	Off
Disable Output	Off
FRQ	1.00 kHz
AMP	9.99 V
OFS	0 V

3. Set up the DVM to read AC voltages up to 10 V.
4. Connect the HP 8116A's main output via a 50 Ω feedthrough terminator to the DVM.
5. Adjust A1R410 until the measured voltage is 5.055 V \pm 25 mV.
6. Set the HP 8116A amplitude to 16 V.
7. Check that the measured voltage is > 8.080 V.
8. Set the HP 8116A amplitude to 1 V.
9. Adjust A1R450 until the measured voltage is 0.504 V \pm 4 mV.

Square Normal/Complement Output Balance

10. Set up the HP 8116A as follows:

AMP	16 V
OFS	0 V

11. Connect the HP 8116A's main output to the DVM, enable the DVM's built-in filter and set the DVM to read DC voltages. If the DVM does not have a built-in filter, use an external low pass filter, as shown in Figure 9-2.

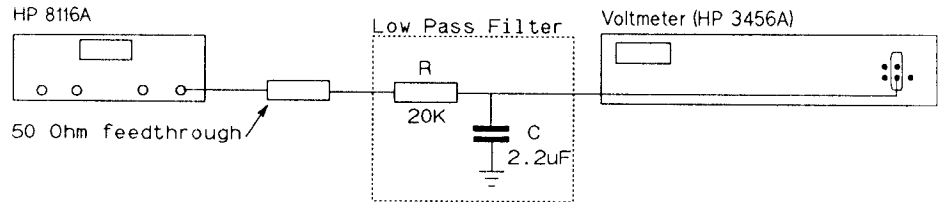

Figure 9-2. Low Pass Filter

12. Switch complement output mode on and off, and adjust A1R403 to obtain the minimum amplitude difference between the 2 modes ($< 10 \text{ mV}$).

Triangle Amplitude

13. Set up the HP 8116A as follows:

Waveform	Triangle
Complement Output	Off
Disable Output	Off
AMP	9.99 V
OFS	0 V

14. Set up the DVM to read AC voltages up to 10 V.
15. Connect the HP 8116A's main output via a 50 Ω feedthrough terminator to the DVM.
16. Adjust A1R227 until the measured voltage is $2.918 \text{ V} \pm 15 \text{ mV}$.
17. Set the HP 8116A amplitude to 16 V.
18. Check that the measured voltage is $> 4.660 \text{ V}$.

2nd Harmonic Distortion

19. Set up the HP 8116A as follows:

Waveform	Sine
Complement Output	Off
Disable Output	Off
FRQ	3 kHz

20. Connect the HP 8116A's main output to the spectrum analyzer.
21. Set up the analyzer to show the fundamental, at 0 dB, and the first two harmonics.(Refer to Figure 9-3).

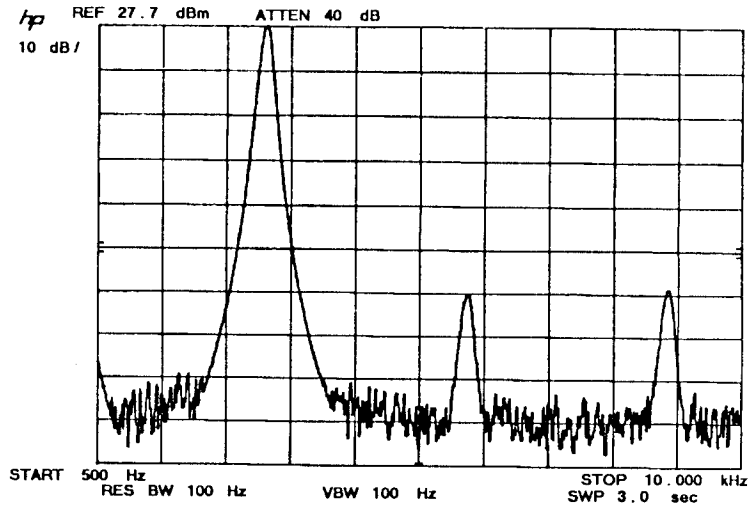

Figure 9-3. Typical Spectrum During 2nd Harmonic Adjustment

22. Adjust A1R409 until the 3rd harmonic is at minimum amplitude.
23. Adjust A1R407 until the 2nd harmonic is at minimum amplitude.
24. Switch the HP 8116A complement-output mode on and off, and adjust A1R407 to obtain the minimum difference between the 2nd harmonic in each mode.
25. If the 2nd harmonic is not < -48 dB in both normal- and complement-output modes, adjust A1R417 until this is achieved.

Sine Normal/Complement Balance

26. Set up the HP 8116A as follows:

Trigger Mode	NORM
Control Mode	Off
Waveform	Sine
Complement Output	Off
Disable Output	Off
FRQ	1.00 kHz
AMP	16 V
OFS	0 V

27. Set up the DVM to read DC voltages up to 10 V.
28. Connect the HP 8116A's main output via a 50Ω feedthrough terminator to the DVM, and enable the DVM's built-in filter. If the DVM does not have a built in filter, use a low-pass filter as shown in Figure 9-2.
29. Switch the HP 8116A complement-output mode on and off, and adjust A1R402 until the difference in output level is < 10 mV between normal- and complement-output modes. If this cannot be achieved, change the value of A1R439 (Refer to Table 9-1), and re-start this procedure from *Square Normal/Complement Output Balance*.

Sine Amplitude & THD

30. Set up the HP 8116A as follows:

AMP	9.99 V
OFS	0 V

31. Set up the DVM to read AC voltages up to 10 V.

32. Connect the HP 8116A's main output via a 50 Ω feedthrough terminator to the DVM, and disable the DVM's built-in filter (or remove the low-pass filter, if connected).

33. Adjust A1R418 until the measured voltage is 3.530 V \pm 10 mV.

34. Set the HP 8116A amplitude parameter to 1 V.

35. Adjust A1R445 until the measured voltage is 0.354 V \pm 1 mV.

36. Set up the HP 8116A as follows:

FRQ	3.00 kHz
AMP	9.99 V
OFS	0 V

37. Connect the HP 8116A's main output to the spectrum analyzer.

38. Set up the analyzer to show the fundamental at 0 dB, and the first 2 harmonics.

39. Adjust A1R409 until the 3rd harmonic's amplitude is a minimum (< -50 dB).

40. Repeat the *Sine Amplitude & THD* procedure until all values are within the given limits.

Triangle Normal/Complement Output Balance

41. Set up the HP 8116A as follows:

Waveform	Triangle
Complement Output	Off
Disable Output	Off
FRQ	1 kHz
AMP	16 V
OFS	0 V

42. Set up the DVM to read DC voltages up to 10 V.

43. Connect the HP 8116A's main output via a 50 Ω feedthrough terminator to the DVM, and enable the DVM's built-in filter. If the DVM does not have a built-in filter, use a low-pass filter as shown in Figure 9-2.

44. Switch the HP 8116A complement-output mode on and off, and adjust A1R401 until the difference in output level is < 10 mV between normal- and complement-output modes. If this cannot be achieved, change the value of A1R439 (Refer to Table 9-1), and re-start this procedure from *Square Normal/Complement Output Balance*.

Sine Offset

45. Set the HP 8116A waveform to sine.
46. Adjust A1R425 until the measured voltage is $0.00\text{ V} \pm 10\text{ mV}$.
47. Set the HP 8116A amplitude to 1 V.
48. Adjust A1R416 until the measured voltage is $0.00\text{ V} \pm 5\text{ mV}$.

Square Low Amplitude

49. Set the HP 8116A waveform to square.
50. Set up the DVM to read AC voltages up to 10 V.
51. Switch off the DVM's built-in filter, or disconnect the low-pass filter.
52. Adjust A1R450 until the measured voltage is $0.506\text{ V} \pm 2\text{ mV}$.
53. Select sine waveform and repeat steps 34 and 35. If any adjustment is necessary, repeat all the rest of the steps up to this point, otherwise, continue from the next step.

THD Check

54. Set up the HP 8116A as follows:

Waveform	Sine
Complement Output	Off
Disable Output	Off
FRQ	3 kHz
AMP	1 V
OFS	0 V

55. Connect the HP 8116A's main output to the spectrum analyzer.
56. Set up the analyzer to show the fundamental at 0 dB, and the first two harmonics.
57. Switch the HP 8116A complement-output mode on and off, and adjust A1R407 until the 2nd harmonic is $< -45\text{ dB}$ in both normal- and complement-output modes. If not, change the value of R428. (Refer to Table 9-1).
58. Set up the HP 8116A as follows:

FRQ	50 MHz
AMP	100 mV
OFS	0 V
59. Set up the analyzer to show the fundamental at 0 dB, and the first two harmonics.
60. Switch the HP 8116A complement-output on and off, and check that the 2nd and 3rd harmonics are $< -26\text{ dB}$ in both cases.

Offset Adjustment

Equipment ■ Digital Voltmeter (HP 3456A)

Procedure

1. Set up the HP 8116A as follows:

Waveform	Sine
Complement Output	Off
Disable Output	Off
FRQ	1 kHz
DTY	50%
AMP	100 mV
OFS	7.95 V
2. Set up the DVM to read DC voltages up to 10 V.
3. Connect the HP 8116A's main output to the DVM and enable the DVM's built-in filter. If the DVM does not have a built-in filter, use a low pass filter, as shown in Figure 9-2.
4. Adjust A2R43 until the measured voltage is $7.95\text{ V} \pm 30\text{ mV}$.
5. Set the HP 8116A offset parameter to -7.95 V .
6. Check that the measured voltage is $-7.95\text{ V} \pm 30\text{ mV}$.
7. If any offset adjustment was required, repeat the "Overshoot & Transition Time Adjustment" procedure before continuing.

Amplitude Modulator Adjustment

Equipment ■ Function Generator (HP 3324A)
■ Oscilloscope (HP 54121T)
■ Spectrum Analyzer (HP 8568B)

Procedure

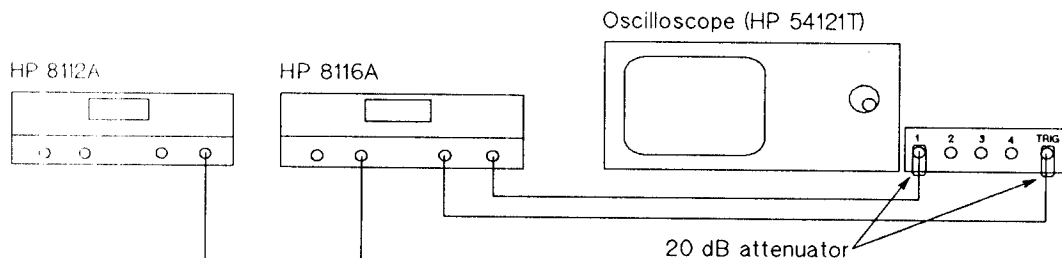

Figure 9-4. Amplitude Modulator Adjustment - Equipment Set-up.

1. Connect the function generator, HP 8116A and spectrum analyzer as shown in Figure 9-4.
2. Set up the HP 8116A as follows:

Trigger Mode	NORM
Control Mode	AM
Waveform	Sine
Complement Output	Off
Disable Output	Off
FRQ	15 kHz
DTY	50%
AMP	16 V
OFS	0 V
3. Set up the function generator as follows:

Waveform	Sine
Frequency	2 kHz
Amplitude	4.5 V
Offset	0 V
4. Adjust the spectrum-analyzer frequency range to display the 15 kHz carrier, the sidebands, the harmonics of the sidebands and the 2 kHz modulation signal as shown in Figure 9-5.

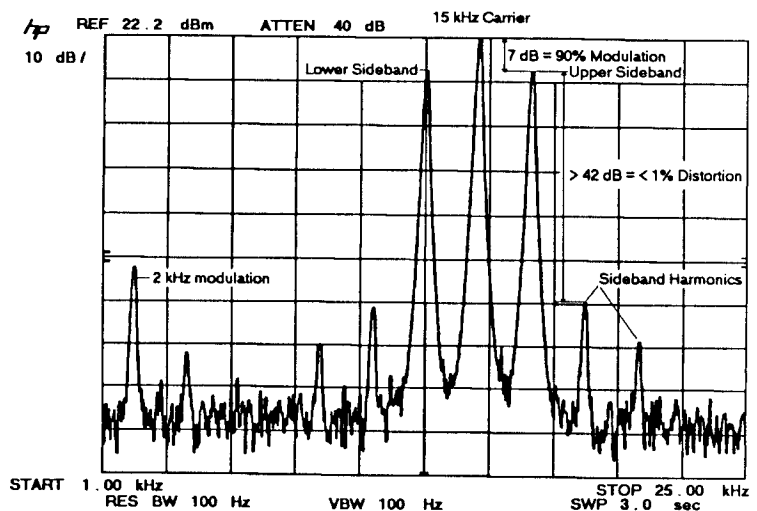

Figure 9-5. Amplitude Modulation Spectrum

5. Adjust the gain of the spectrum analyzer so that the carrier level is 0 dB.
6. Adjust the function generator's amplitude until the modulation sidebands are 7 dB down from the carrier. This corresponds to a modulation level of 90%.
7. Set A1R413 to its middle position.
8. Adjust A1R414 to minimize the level of the 2 kHz modulation signal and its 4 kHz harmonic.

9. Set the HP 8116A amplitude to 1 V.
10. Adjust the spectrum analyzer so that the carrier level is 0 dB.
11. Re-adjust A1R414 to minimize the level of the 2 kHz modulation signal and its 4 kHz harmonic.
12. Repeat the procedure up to this point in order to get the best compromise at both amplitude levels.
13. Verify that, at both amplitudes, all harmonics of the sidebands are at least 42 dB lower than the sidebands (49 dB lower than the carrier). Remember to adjust the spectrum analyzer each time you change the HP 8116A amplitude level, so that the carrier level is 0 dB.
14. Perform, or repeat, the following parts of the procedure in "Shaper Adjustments":
 - Sine Normal/Complement Output Balance
 - Steps 34 & 35 of Sine Amplitude & THD
 - Triangle Normal/Complement Output Balance
 - Square Low Amplitude (Set HP 8116A amplitude to 1.00 V)
15. Repeat step 13 of this procedure.
16. Disconnect the HP 8116A's main output from the analyzer and connect it to the oscilloscope via 40 dB attenuation.
17. Connect the sync output (or the main output) from the function generator to the oscilloscope's trigger input.
18. Set up the HP 8116A as follows:

FRQ	15 kHz
AMP	16 V
19. Set up the function generator as follows:

Amplitude	5 V
Offset	0 V
20. Adjust the function generator amplitude and offset until the HP 8116A has 100% modulation and minimum offset as shown in Figure 9-6. Figure 9-7 shows an incorrectly adjusted example.

P/O A1 BD AY

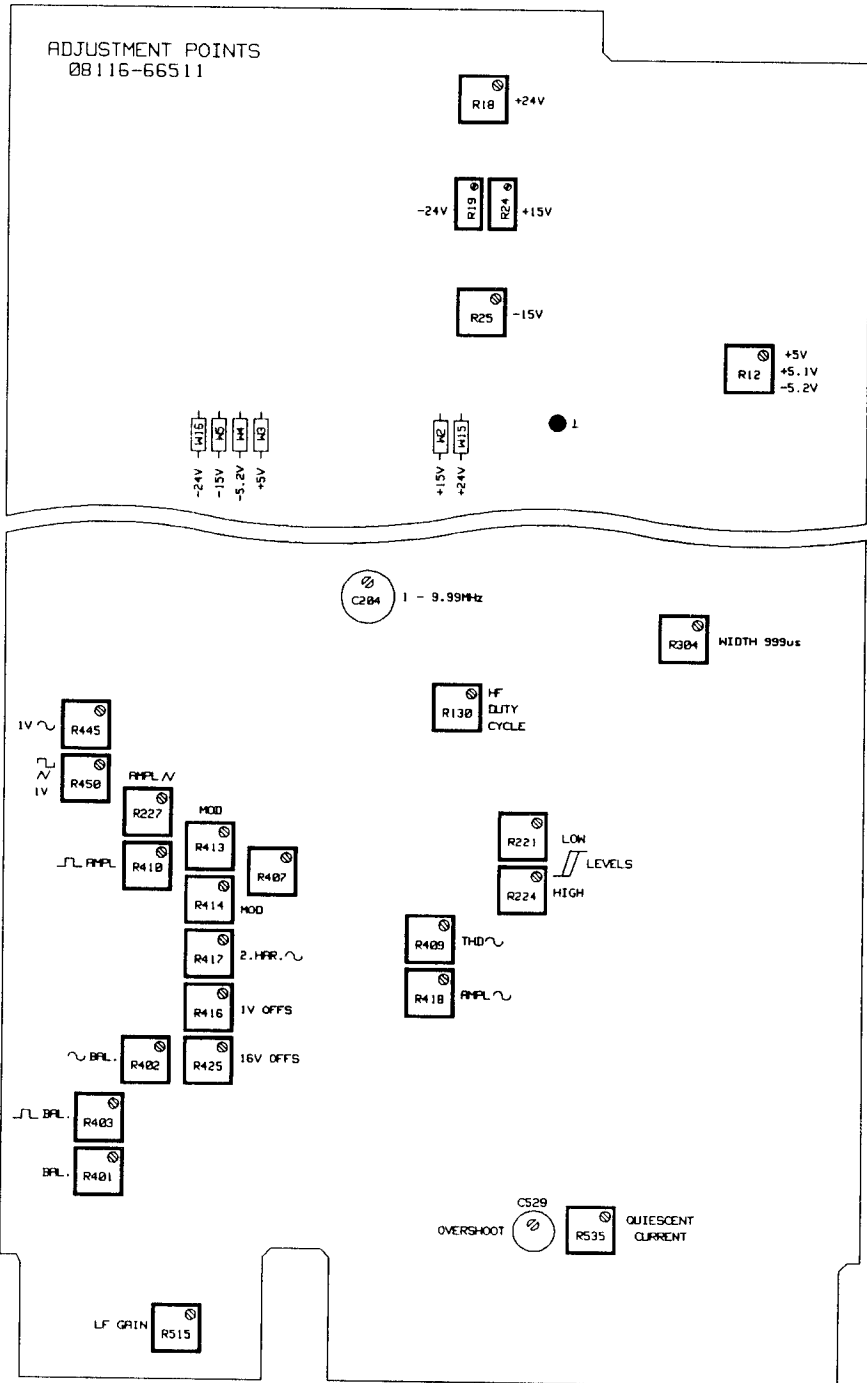

Figure 9-8. Adjustment Points on the Main Board A1

P/O A2 BD AY

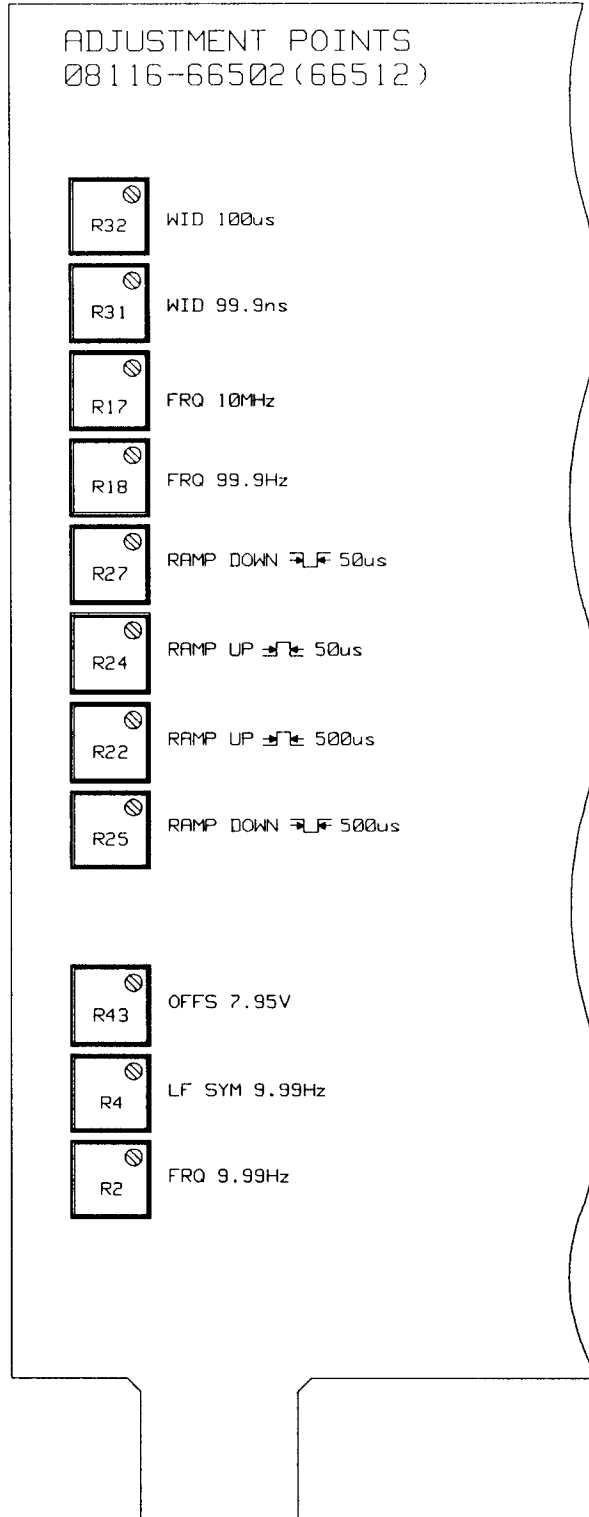

Figure 9-9. Adjustment Points on the Control Board A2

Introduction to Servicing

Safety Considerations

Warning



Dangerous voltages, capable of causing serious personal injury, are present in this instrument. Use extreme caution when handling, testing and adjusting.

The servicing described in the following chapters is performed with the instrument switched on and its protective covers removed. Therefore, servicing *must* only be carried out by a skilled person, who is aware of the hazards involved, and in the presence of another person who is capable of rendering first aid and resuscitation.

Capacitors inside the instrument may still be charged after the instrument has been disconnected from its external power supply.



The HP 8116A contains static-sensitive devices. Ensure that “static-safe” precautions are taken to prevent electro-static discharge when the instrument has its covers removed.

Safety Check

The following safety checks must be carried out after any servicing is completed:

1. Disconnect the power cord from the external voltage supply.
2. Inspect the interior of the instrument for any signs of abnormal overheating or arcing, such as:
 - Discolored circuit board
 - Discolored components
 - Damaged insulation

If a problem exists, it *must* be investigated and fixed before proceeding.

3. Check the case to power-cord ground-pin continuity in accordance with IEC & VDE. Flex the power cord during the measurement to check for any intermittent discontinuity. If a problem exists, it must be investigated and fixed before proceeding.
4. Check the internal ground connections between circuit boards and the instrument frame. If a problem exists, it must be investigated and fixed before proceeding.

5. Check that the case is isolated from the power-cord power-pins in accordance with IEC & VDE. If a problem exists, it must be investigated and fixed before proceeding.
6. Check that the correct line fuse is fitted.
7. Check that all safety covers are fitted.
8. Check that all inter-connecting co-axial and flat cables are properly connected.
9. Check that all boards are properly fitted.
10. Check that the heatsink connections between the main board and the front frame member are secure.
11. Inform Hewlett-Packard of any repeated failures of any of the checks, or any other safety features.

General

The servicing information is divided into chapters as summarised here:

Instrument Overview and Troubleshooting Guide	This chapter deals with the overall instrument and is intended to help you to isolate a fault at a functional level. You can then proceed to the appropriate chapter which covers that function in more detail.
Servicing the Power Supply	This chapter deals with the power supply, including rectification, regulation, voltage and current sensing and power-down detection.
Servicing the VCO and Width Generator	This chapter covers the trigger-input circuits, slope generator IC, timing IC, error feedback circuit and the vernier feedback circuit.
Servicing the Shaper and Output Amplifier	This chapter covers the shaper IC, amplitude modulator, current mirror, pre-attenuator, signal output amplifier, output attenuator and the trigger-output amplifier.
Servicing the Standard Control Board	This chapter covers the byte-offset latches, Digital to Analog Converters, timer, reference circuits, and the width-vernier current source.
Servicing the Option 001 Control Board	This chapter covers the burst counter, blocking flip-flop, X-Output generator, Marker Output, and the Hold Input.
Servicing the Microprocessor and Frontpanel	This chapter covers the microprocessor board including ROM, RAM, HP-IB interfacing, address decoding and the RAM battery supply. It also covers the keyboard and display board which make up the frontpanel.

Each of these chapters contains an explanation of the theory of operation, a troubleshooting guide and circuit schematics. Component layouts for each board assembly are also provided. The five board assemblies contained in the HP 8116A are listed in Table 10-1 which lists the servicing chapters applicable to each board.

Table 10-1.
HP 8116A Board Assemblies & Servicing Chapters

Assembly	Reference	Chapter(s)
Main Board	A1	10.2, 10.3, 10.4
Control Board	A2	10.5, 10.6
Microprocessor Board	A3	10.7
Keyboard	A4	10.7
Display Board	A5	10.7

Instrument Overview and Troubleshooting Guide

Theory of Operation

The block diagram in Figure 10.1-1 shows the HP 8116A at a functional level.

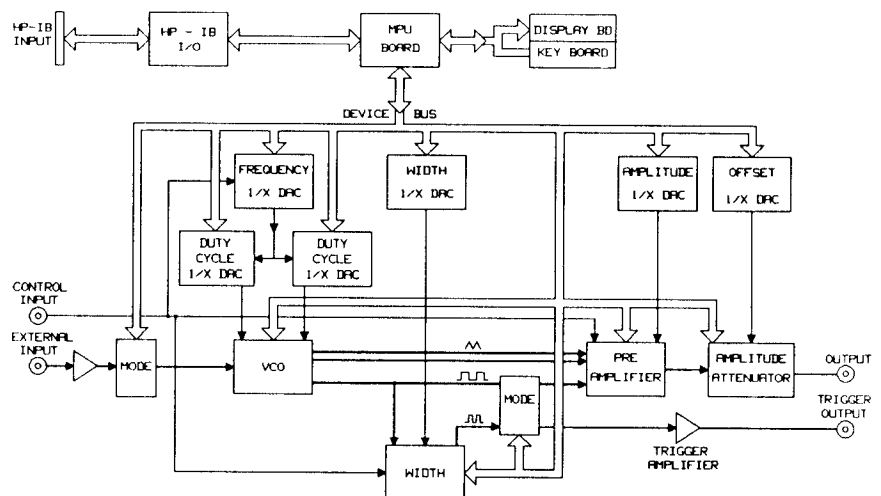

Figure 10.1-1. HP 8116A Functional block diagram

The microprocessor controls the operation of the instrument by reading inputs from the frontpanel keyboard or the HP-IB, and sending the appropriate data to the Digital-to-Analog Converters (DACs) which control the generator hardware. It also updates the frontpanel LEDs and display in response to the keyboard and HP-IB inputs.

The generator hardware contains three specially developed HP ICs:

VCO (Slope) IC

This is used as a triangle waveform generator up to 50 MHz (VCO), with the output either continuous, gated or triggered. It is also used as a burst generator with Option 001.

Timing IC

This is used as a triggerable pulse-width generator and a trigger source for Internal

Burst Mode. For Pulse Width Modulation, the external signal applied to the Control Input controls the pulse width.

Shaper IC

This is used as a linear preamplifier and triangle to sine converter.

The ICs and their supporting circuitry are covered in more detail in the relevant parts of the later chapters, however, the IC pin identities are given in Figure 10.1-2.

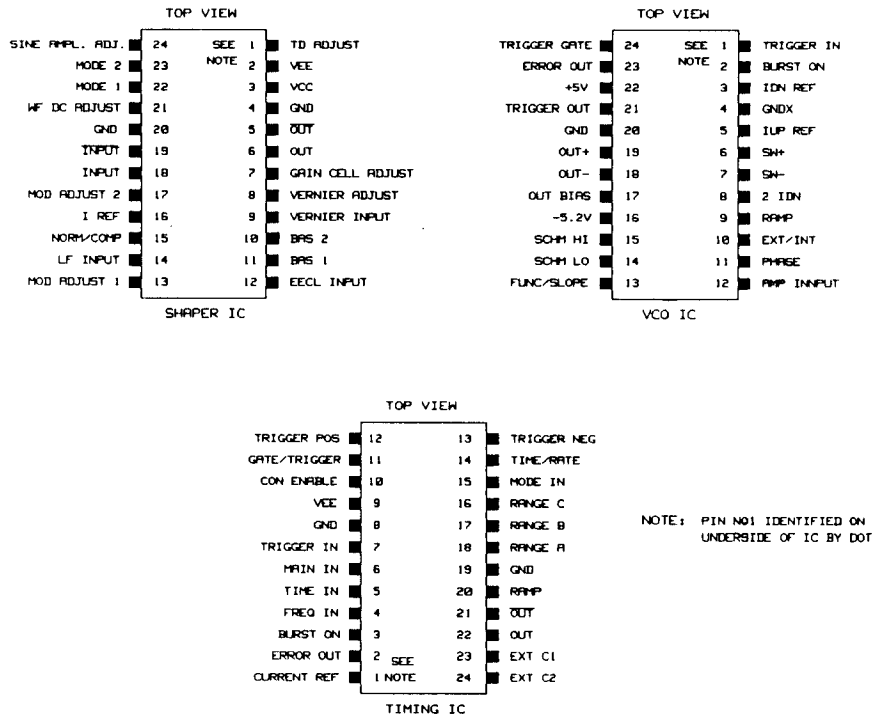

Figure 10.1-2. Custom ICs used in the HP 8116A

Troubleshooting

Every time the instrument is switched on, or when an EST command is received on the HP-IB, the HP 8116A executes a self-test. If a fault is detected an error code is displayed, otherwise the instrument is ready for operation. The error code can be used to locate the fault by referring to the following flowcharts. If more than one fault exists, only the first one is detected and displayed. After this is successfully repaired, the self-test will be able to proceed further and detect any remaining faults.

Note



Flashing of the frontpanel lamps indicates a fault related to the ± 24 V supplies. Refer to “ ± 24 V supplies” in Chapter 10.2.

Preparing the HP 8116A for servicing



The HP 8116A contains static-sensitive devices. Ensure that “static-safe” precautions are taken to prevent electro-static discharge when the instrument has its cover removed.

1. Remove the rear of the instrument by unscrewing the two TORX fastening screws.
2. Remove the single screw securing the instrument’s case underneath the instrument.
3. Remove the case by sliding it backwards. You may need to use a screwdriver in one of the case ventilation holes to gently lever the case back. It is held tightly by the RFI seals at the front of the frame.
4. Remove the four screws securing the microprocessor board.
5. Lift the microprocessor board and stand it vertically by placing the cut-outs on the edge of the board over the locating lugs on the inside of the right-hand side-panel (as seen from the front of the instrument).
6. Remove the screen covering the control board.
7. Lift the control board and stand it vertically on the inside of the left-hand side-panel.

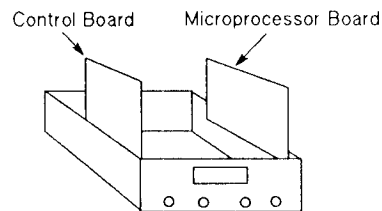
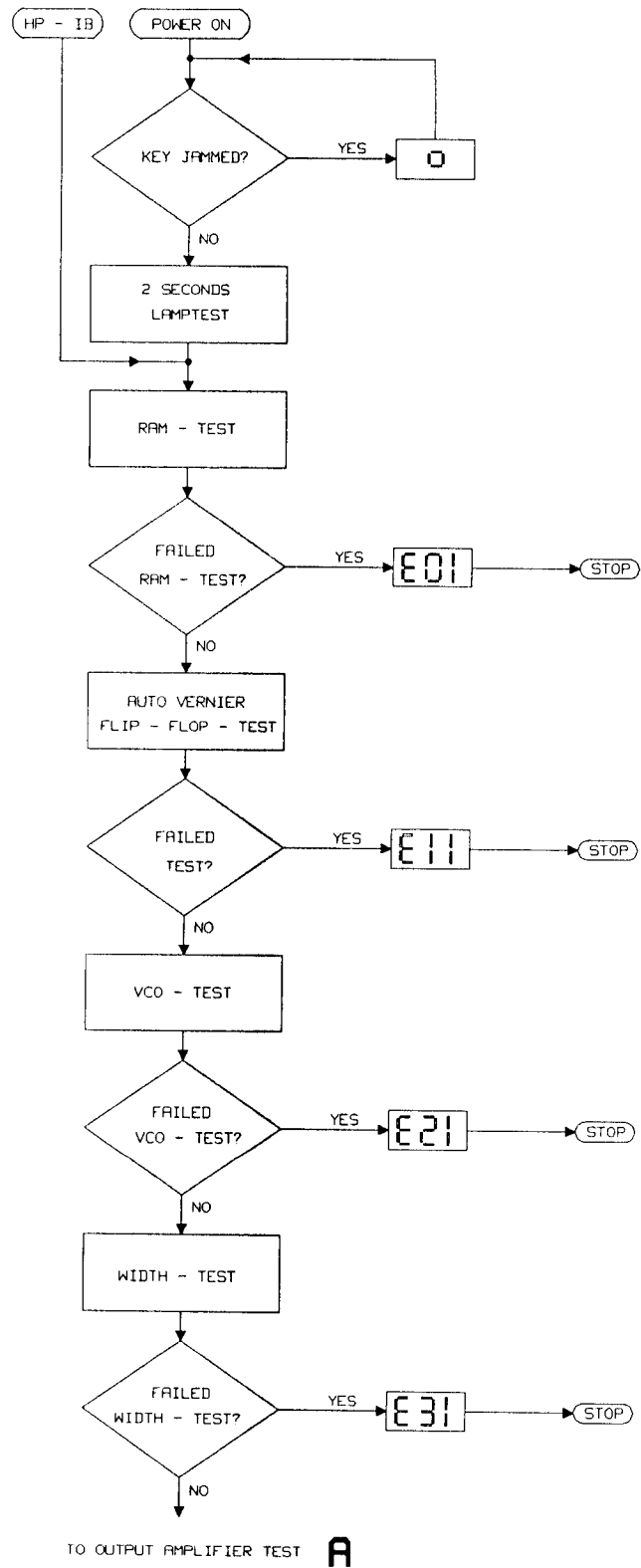

Figure 10.1-3. HP 8116A in its servicing position



10.1-4 Instrument Overview and Troubleshooting Guide

Key Jammed

O

A frontpanel key is stuck. The instrument cannot be used until it is freed.

RAM Test

E01

The microprocessor is unable to load a test pattern into the RAM U10 and verify it. In order to avoid influence from the control or main board, remove the device-bus cable from the main board A1 at connector J2 (See Figure 10.4-8) and from the control board A2 at connector J5 (See Figure 10.5-8).

Flip-flop Test

E11

The autovernier flip-flop is not setting or resetting. Either the main board A1 is not connected, or there is a failure in latch U103, NOR gate U102, buffer U302, or Q102. In order to avoid influence from the control board, unplug the device bus cable from the control board A2 at connector J5 (See Figure 10.5-8).

VCO Test

E21

The VCO (Slope) IC U201 is unable to supply a period of 10 ms. Possible faults:

- Frequency DAC A2: U6
- Duty cycle DACs A2: U8 - U12
- Current sources A1: U200B - U200D, Q200 - Q202
- Burst flip-flop A1: U203
- Reference voltage A1: U200A, U202, U205
- Latch A1: U150
- Error feedback A1: U301, U302, Q302

Refer to Chapter 10.3 and Chapter 10.5.

Width Test

E31

The Timing IC U300 is unable to generate pulses of 5 ms and 25 ms. Possible faults:

- Width DAC A2: U13, U5, U17
- Control mode selector A1: U152
- VCO (Slope) IC A1: U201, Q220
- Error feedback A1: U301, U302, Q302

Refer to Chapter 10.3 and Chapter 10.5.

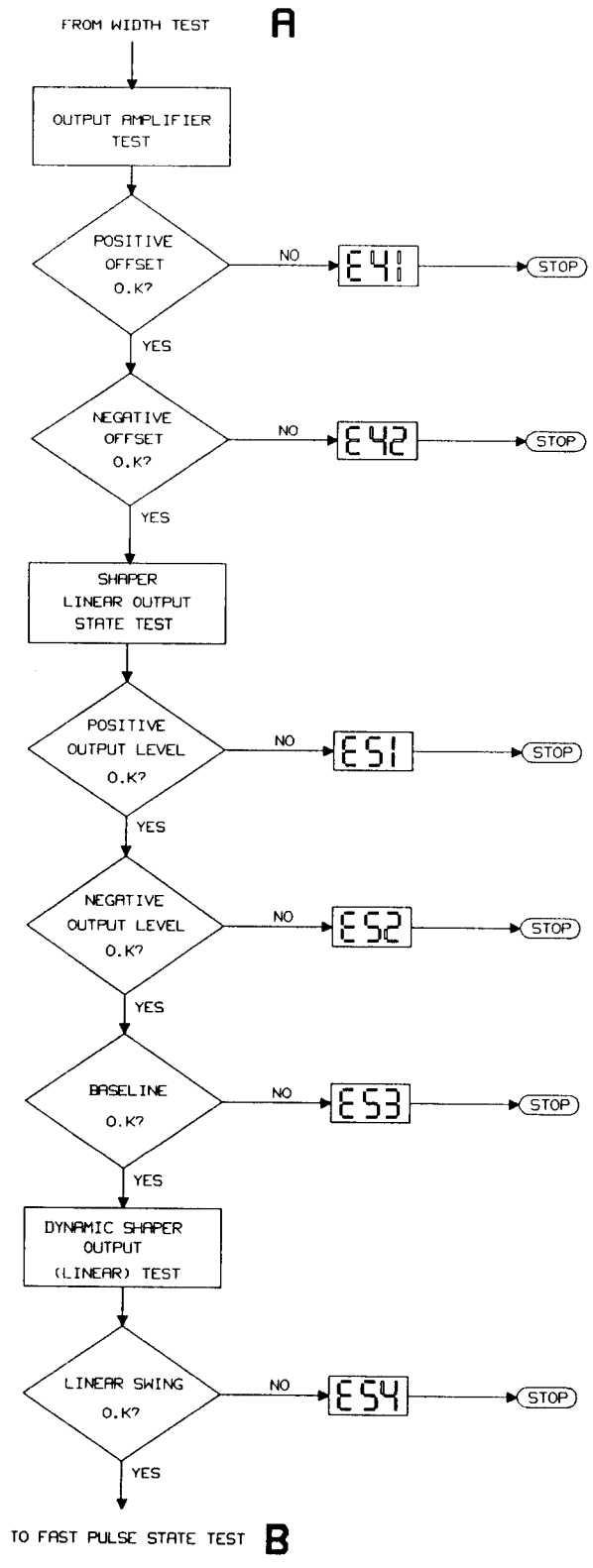

Output Amplifier Test

E41

The output amplifier is unable to supply a positive offset, see below for possible failures.

E42

The output amplifier is unable to supply a negative offset. Possible faults:

- Output amplifier A1
- Offset DAC A2: U24, U25, U26, U17
- Offset latches A2: U21, U22, U23, U43

Refer to Chapter 10.4 and Chapter 10.5.

Shaper Output State Test

E51

The shaper IC U401 is not able to supply positive output when -90° startphase and complement output mode are selected with triangle waveform (VCO not triggered). Possible faults:

- VCO (Slope) IC A1: U201
- Waveform switching A1: U104
- Reference voltage switching A1: U204
- Amplitude DAC A2: U27, U28, U17

Refer to Chapter 10.5, Chapter 10.3 and Chapter 10.4.

E52

The shaper IC U401 is not able to supply negative output when -90° startphase and complement output mode are selected with triangle waveform (VCO not triggered). Refer to E51 for the possible faults.

E53

The shaper IC U401 supplies an illegal offset when 0° startphase is selected (VCO not triggered). Refer to E51 for the possible faults.

Shaper Dynamic Output Test

E54

The shaper IC U401 output is distorted and/or not symmetrical when an output amplitude of 15.2 V is selected in normal mode. Possible faults:

- Reference voltage A1: U200A, VR200, R240 - R242, U204
- VCO (Slope) IC A1: U201, R226, R227

Refer to Chapter 10.3 and Chapter 10.4.

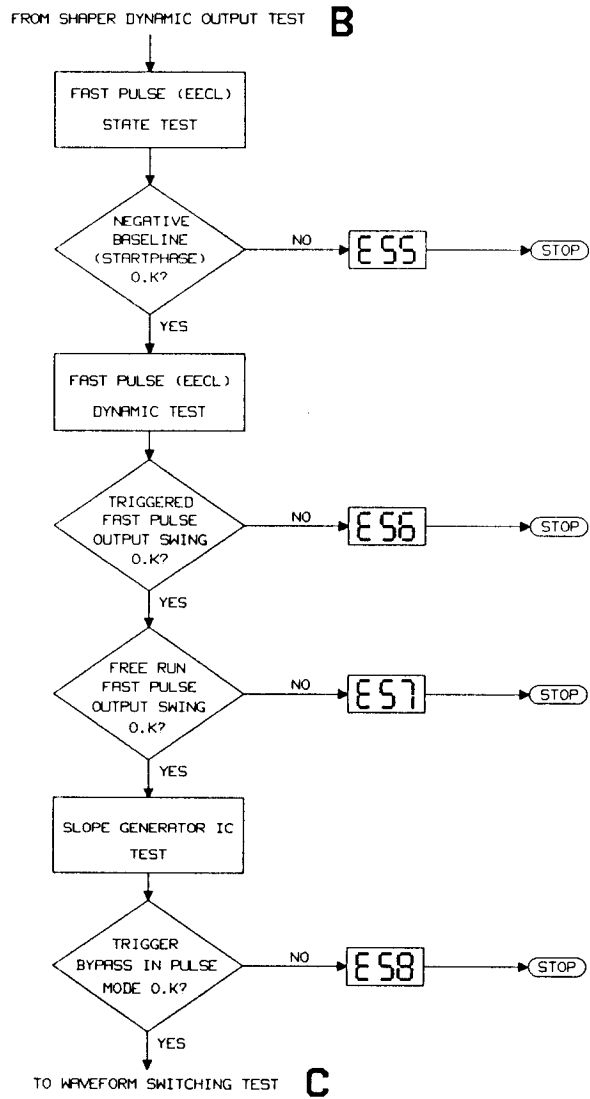

Fast Pulse State Test

E55

The shaper IC U401 is not able to supply negative output when -90° startphase and square waveform are selected (VCO not triggered). Possible faults:

- Waveform switching A1: U104
- Shaper IC A1: U401

Refer to Chapter 10.3 and Chapter 10.4.

Fast Pulse Dynamic Test

E56

The shaper IC U401 is not able to supply a squarewave when an output amplitude of 15.2 V is selected in trigger mode. Possible faults:

- Trigger slope A1: U102
- Latch A1: U103
- Waveform switching A1: U104
- Shaper IC A1: U401

Refer to Chapter 10.3 and Chapter 10.4.

E57

The shaper IC U401 is unable to supply a squarewave when an output amplitude of 15.2 V is selected in normal mode. Possible faults:

- Waveform switching A1: U104
- Shaper IC A1: U401

Refer to Chapter 10.3 and Chapter 10.4.

Slope Generator (VCO) IC Test

E58

The VCO (Slope) IC U201 cannot pass the external trigger signal to the timing IC, or the timing IC is not generating an output. Possible faults:

- VCO (Slope) IC A1: U201
- Timing IC A1: U300, Q300

Refer to Chapter 10.3.

FROM SLOPE GENERATOR IC TEST **C**

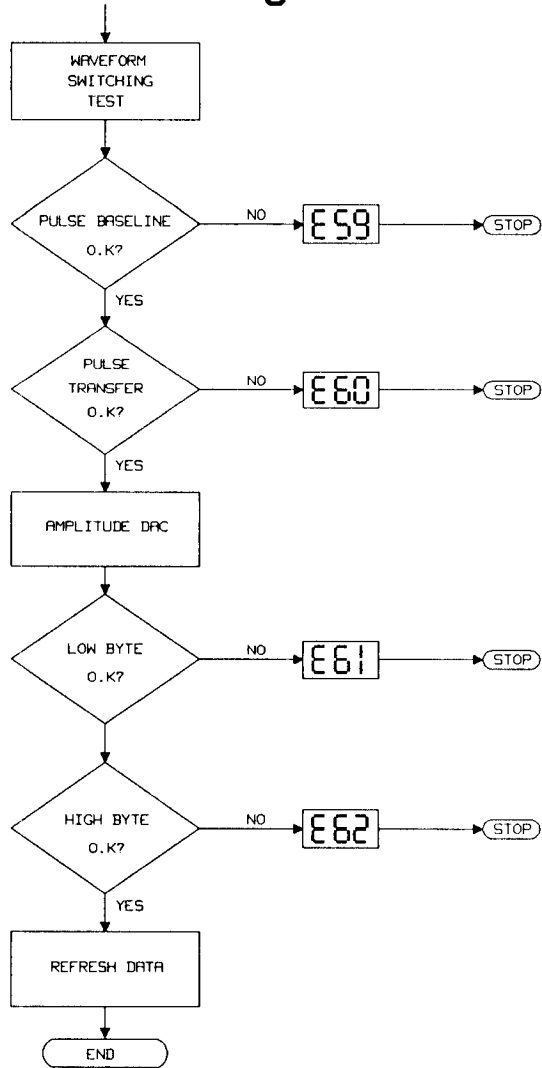

Waveform Switching Test

E59

The shaper IC U401 is not able to supply a negative output when pulse mode is selected (not triggered). Possible faults:

- Waveform switching A1: U104
- Timing IC A1: U300, Q300

Refer to Chapter 10.3.

E60

The shaper IC is not able to supply pulses when an output amplitude of 15.2 V is selected with pulse waveform in normal mode. Refer to E59 for the possible faults.

Amplitude DAC Test

E61

The shaper IC U401 is unable to supply high positive output when an output amplitude of 9.19 V is selected in trigger mode with -90° startphase and complement output mode. Check the amplitude DAC A2: U27, U28, U17. Refer to Chapter 10.5.

E62

The shaper IC U401 is unable to supply low positive output when an output amplitude of 1.51 V is selected in trigger mode with -90° startphase and complement output mode. Check the amplitude DAC A2: U27, U28, U17. Refer to Chapter 10.5.

Servicing the Power Supply

Theory of Operation

Introduction

The HP 8116A power supply unit occupies part of the main board A1 and consists of the following four parts, as shown in Figure 10.2-1:

- Line voltage selector and transformer
- Voltage rectifiers and regulators
- Voltage and current sensing circuits
- Power-down detection circuit

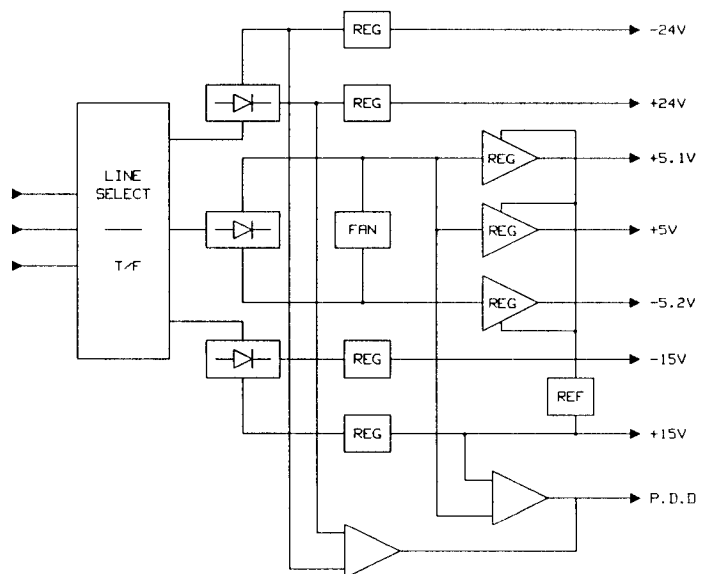

Figure 10.2-1. Power Supply block diagram

Line Voltage Selector and Transformer

Refer to Figure 10.2-2. The line-voltage selector-switches, S2 and S3, connect the incoming line-voltage lines to an appropriate pair of transformer inputs. The transformer provides six ac outputs and an earth line to the bridge rectifiers.

Bridge Rectifiers and Regulators

There are three bridge rectifiers, all modular and therefore replaceable:

Table 10.2-1. Power supply rectifiers

Rectifier	Output
CR1	± 5 V DC
CR2	± 24 V DC
CR3	± 15 V DC

The raw voltage outputs are all smoothed by capacitors, as shown in Figure 10.2-3. The following supplies are then fed to voltage regulators, with potentiometers to adjust the final voltage level:

Table 10.2-2. Regulated voltage supplies

Supply	Regulator	Adjustor
+24 V	U3	R18
-24 V	U4	R19
+15 V	U5	R24
-15 V	U6	R25

Voltage and Current Sensing Circuits

The smoothed ± 5 V DC outputs of CR1, which drive the fan, also provide the basis for the voltage and current sensing circuits which control the +5.1 V, +5 V and -5.2 V supplies.

+5.1 V supply

A reference voltage of 5.1 V is obtained from the +15 V regulated supply, using zener diode VR1 (6.2 V), R11 and R12. U1C compares the +5.1 V supply with this reference voltage and drives the regulator transistor Q1, via driver transistor Q2, until there is zero difference.

If the current drawn from the +5.1 V supply is excessive, a distinct voltage drop develops across R2. U1D detects this and its output switches toward the negative supply. This forward-biases diode CR8, switches off Q2 and Q1, and hence the +5.1 V supply is withdrawn.

+5 V supply

The same principles of operation apply to the +5 V voltage regulator, U2C, and current sensor, U2B. The 5 V reference is obtained from the 5.1 V reference via R13.

-5.2 V supply

The -5.2 V reference is obtained from the 5 V reference using U2D as an inverter with a gain of 1.04. The voltage regulator U1B and the current sensor U1A operate as above except that the comparator

output is normally negative and switches positive to withdraw the supply.

±24 V supplies

If the current drawn through R35/R36 becomes excessive, the normally negative output of U7A switches towards the positive supply. C20 then charges through R37 until the threshold of the Schmitt trigger U7B is reached. The output of U7B goes negative, switching on Q8 which withdraws the -24 V output of U4. Similarly, the output of U7C goes positive, switching on Q7 which withdraws the +24 V output of U3. In addition, the output of U7D goes positive for approximately 1 ms and a Power Down Detected signal is generated.

The Power Down Detected signal resets the microprocessor, however when the ±24 V supplies are withdrawn the excessive current in R35/36 is removed and the current-sensing circuits re-enable the supplies. The microprocessor restarts and runs the instrument self-test, beginning with the frontpanel lamp-test, until the current becomes excessive again.

This cycle repeats continuously and therefore the frontpanel lamps flash, as the self-test is never completed before the microprocessor resets again. Refer to the Troubleshooting part of this chapter for more information.

Power-down Detection

U2A is used to detect the power being switched off. Normally its output is negative because its inverting input is at a higher potential (5.1 V) than its non-inverting input (5 V). When the HP 8116A is switched off, the 5.1 V supply breaks down faster than the 5 V reference because it is loaded by the microprocessor board. This is detected by U2A which switches its output towards its positive supply.

The Power Down Detected signal is also generated by the ±24 V supply current-sensing circuits, as described in “±24 V supplies” above.

This Power Down Detected signal is used on the microprocessor board to ensure that the microprocessor and HP-IB switch off cleanly. Refer to Chapter 10.7.

P/O A1 MAIN BOARD

A

B

C

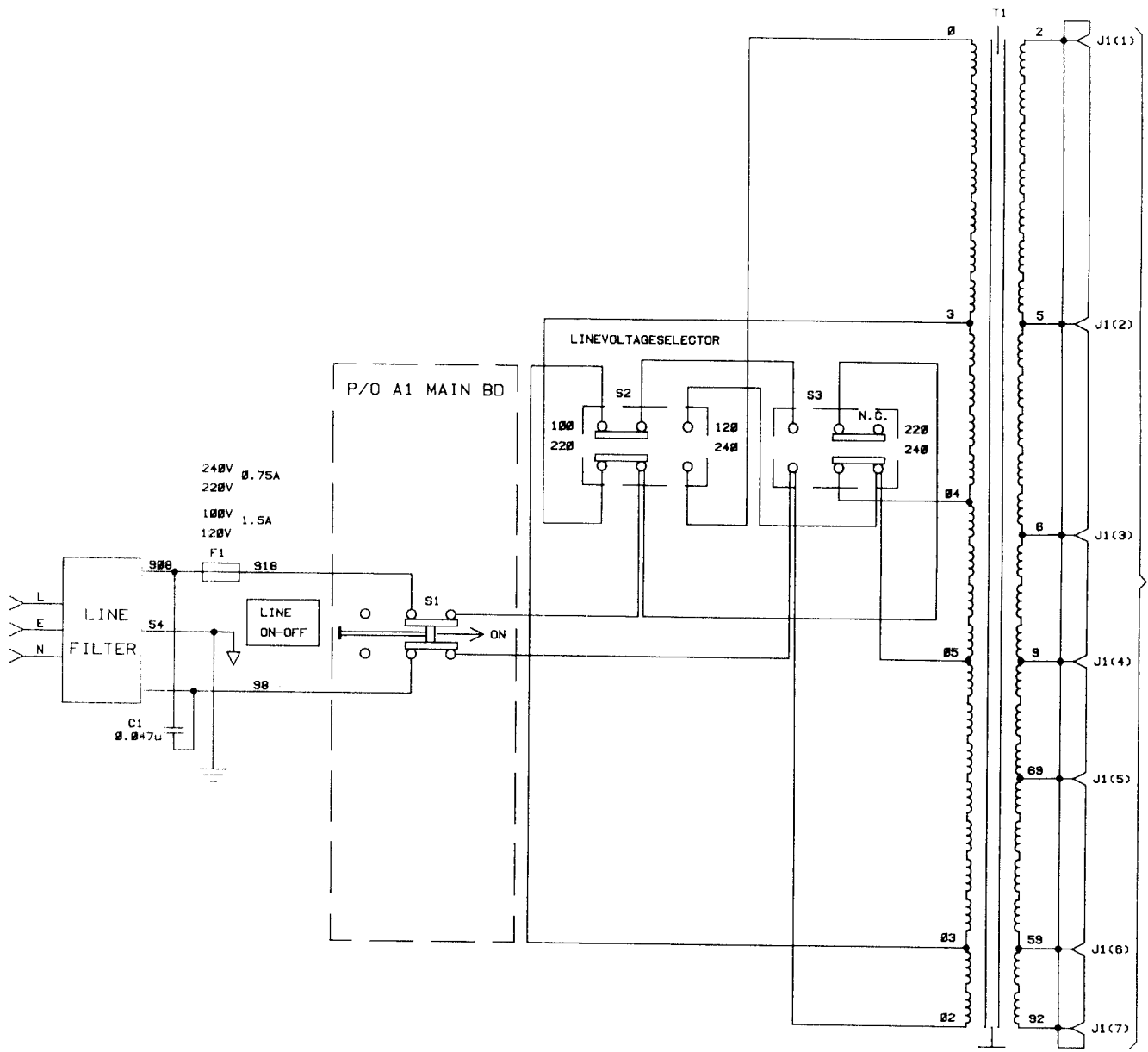

C1 DIRECT SOLDERED TO LINE FILTER

MODEL HP8116A
FIGURE 10.2-2.
MAIN BOARD A1 SCHEMATIC 1

P/O A1 MAIN BOARD

1

2

3

SERVICE

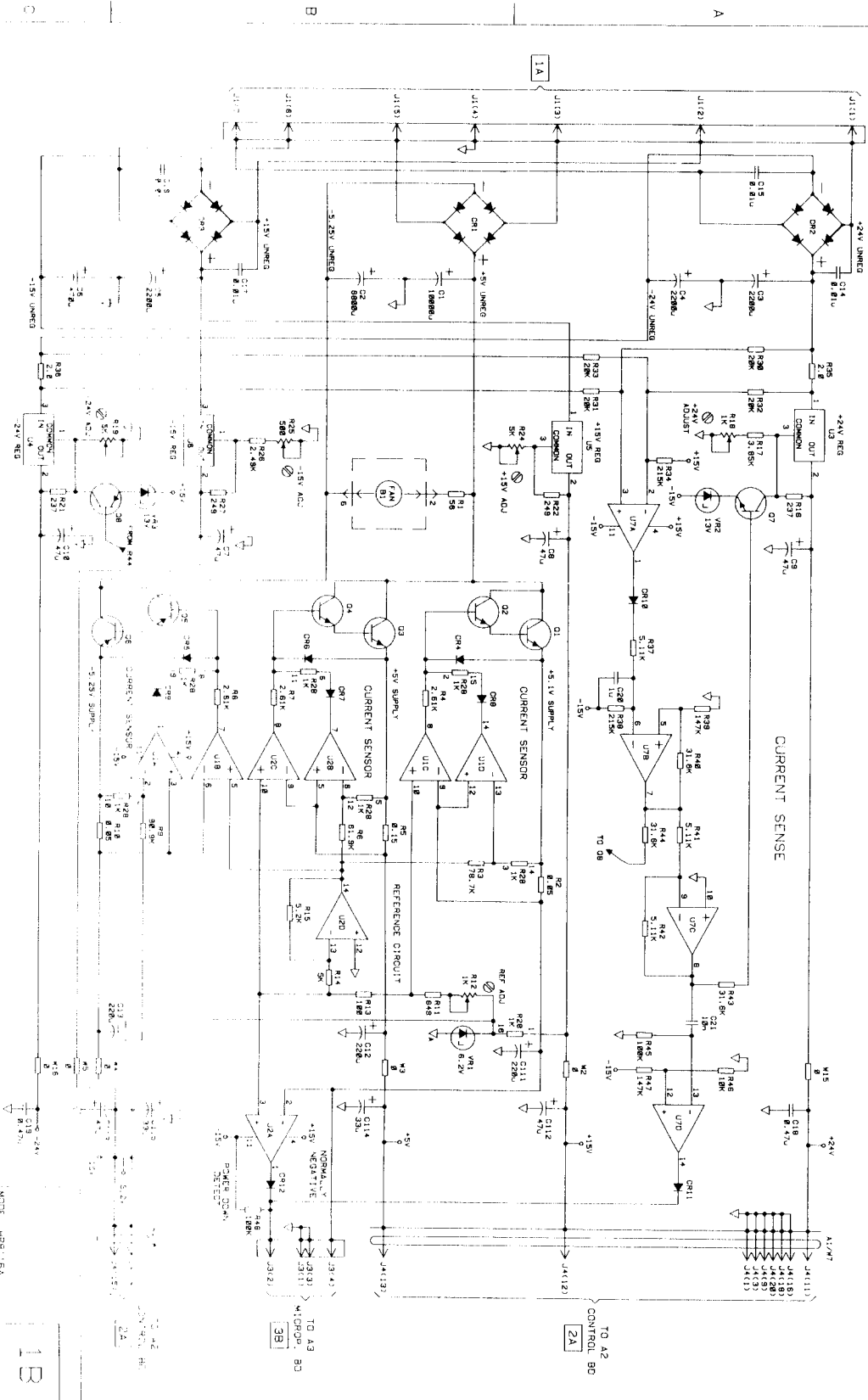

1B

NODE: 08115A
REV: 01/13
DATE: 01/13
SHEET: 01 OF 04
SERIAL: 01/13

Troubleshooting the Power Supply

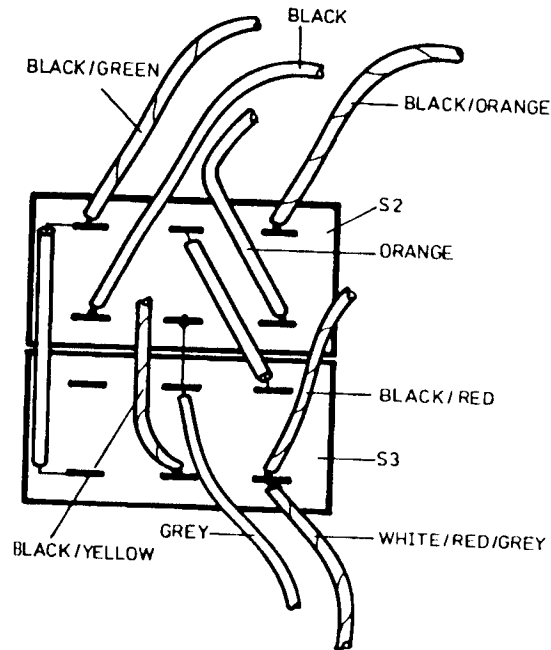

Figure 10.2-4. Detail of wiring to Line Voltage Selector switches

Removing the fan

Starting with the instrument in its Servicing position:

1. Unplug the red and blue wires connecting the fan to the main board.
2. Remove the four screws securing the fan to the rear of the frame.
3. Take out the fan assembly.

Re-fitting the fan

1. Orient the fan so that the arrow on its case (indicating the direction of air-flow):
 - points to the rear of the instrument
 - and is on the bottom.
2. Secure the fan to the rear of the frame using the four screws, keeping the arrow at the bottom and pointing outwards.
3. Plug the red cable onto the pin marked 2, on the main board, routing the cable between the side of the frame and the heatsink.
4. Plug the blue cable onto the pin marked 6.

± 24 V supplies

If the frontpanel lamps flash when the instrument is switched on, this indicates that excessive current is being drawn from the +24 V or -24 V supply, as described earlier in “ ± 24 V supplies” in the Theory of Operation. This fault is often caused by a short-circuited transistor in the output amplifier. To identify which supply is overloaded:

1. Make sure the instrument is disconnected from its power source.
2. Remove W15, this disconnects the +24 V supply from the rest of the instrument.
3. Reconnect the instrument and switch it on.

If the frontpanel lamps still flash, the excessive current is being drawn from the -24 V supply

If the frontpanel lamps no longer flash, the excessive current was being drawn from the +24 V supply.

4. Disconnect the instrument, replace W15 and investigate the cause of the overload (Refer to Chapter 10.4 as necessary).

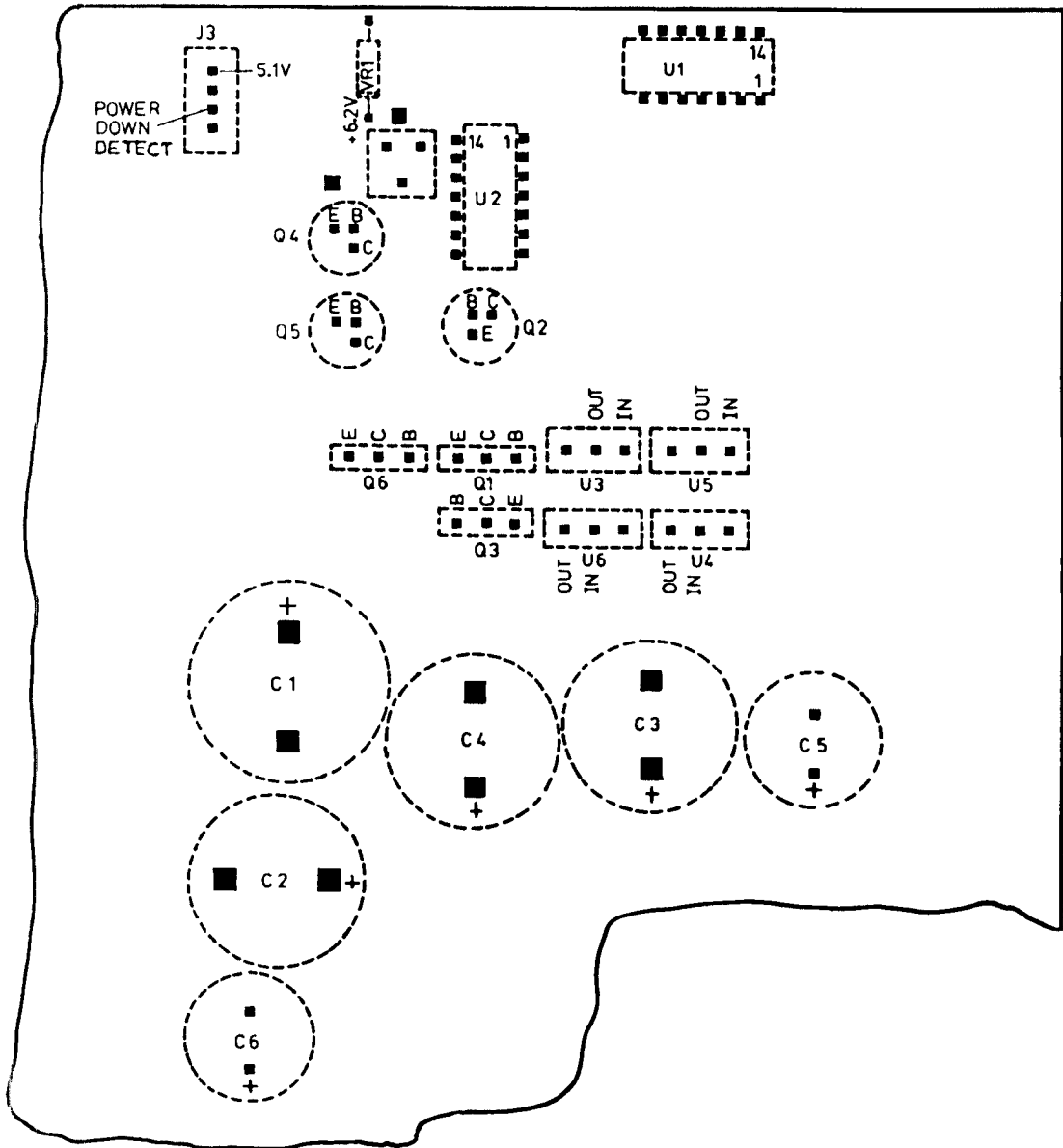

Figure 10.2-5. Power supply components - Underside of main board A1

Note



The main component layout and locator for the main board A1 are in Chapter 10.4

Servicing the VCO and Width Generator

Theory of Operation

Introduction The majority of the slope generation and timing/width circuitry is on the main board A1. A small part of the associated circuitry is on the control board A2. The operation of the VCO and width/timing circuits is explained under the following functions:

- Trigger input circuits
- Control input circuits
- VCO (Slope) IC
- Timing IC
- Error and vernier feedback

Trigger Input Circuits The trigger input circuits can be divided into three stages:

Trigger-level Circuit

The trigger-level circuit provides the required trigger-level to the second stage without affecting the external trigger source. Figure 10.3-1 shows a simplified view of the circuit, refer to Figure 10.3-5 for the circuit details.

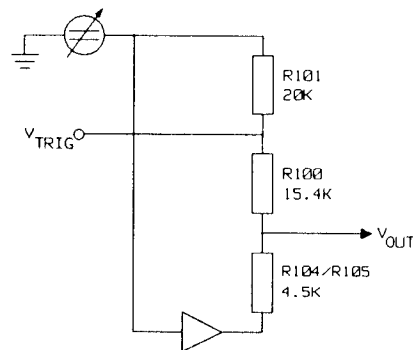

Figure 10.3-1. Simplified Trigger-level circuit

Op-amp U101A provides a fixed voltage of -1.25 V and allows R106, “Trigger Level Adjust”, to act as the variable voltage source shown in Figure 10.3-1. U101B is an inverting amplifier with unity gain and provides a voltage of equal magnitude but opposite polarity to the bottom-end of the divider chain formed by R101, R100 and R104/5. Therefore, by varying R106, the DC component of V_{out}

varies accordingly. V_{out} then passes through a high-to-low impedance converter formed by Q100 and Q101.

Trigger amplifier

The trigger amplifier is a three-stage ECL circuit with Schmitt-trigger characteristics. Each op-amp stage U100B/D/C has both its main and complementary outputs pulled down to -5.2 V via 470 Ω . The threshold of the circuit is fixed at -1.3 V.

Trigger selector

The microprocessor selects the final trigger signal from

- Internal burst trigger
- Manual trigger from **MAN**
- Negative slope trigger from the trigger amplifier
- Positive slope trigger from the trigger amplifier

by enabling one of the four ECL NOR gates U102A/B/C/D via the trigger mode latch U103. R116, R117 and R118 convert the latch TTL levels to ECL levels.

Control Input Circuits

Refer to Figure 10.3-5. The control input signal is clamped within ± 15 V by the protection diodes CR151 and CR152. The signal passes through a unity-gain non-inverting buffer (U151) and is clamped within $+5/-5.2$ V by CR153 and CR154. The signal then passes to the control-mode selector U152 where control-signals M1 and M2 from the control latch U150 select its route according to Table 10.3-1:

Table 10.3-1. Control signal output from U152

Control Mode	Output pin
AM	15
FM	14
VCO	12
PWM	4 via 11

Note that in AM mode the U151 output is processed directly by the amplitude modulator, hence pin 15 of U152 is grounded.

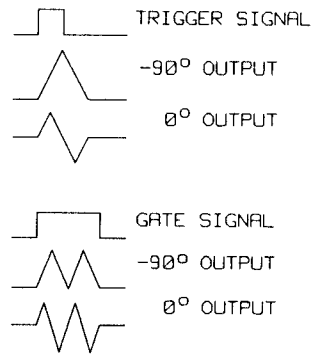

Figure 10.3-3.

The relationship between startphase and triggering signal

Range Switches

The ramp timing capacitance is selected from range latch U210. Frequencies from 1 mHz to 10 MHz are possible with the external capacitors, frequencies > 10 MHz use the internal capacitor in U201. Note that a capacitance amplifier, located on control board A2, is used to provide the high capacitances required at frequencies < 10 Hz.

VCO IC Schmitt Trigger

U201 uses an internal Schmitt trigger to detect the threshold voltages on the timing capacitor and switch the analog circuitry within the IC. The upper and lower switching thresholds are set externally by the high and low level adjust circuits (U202A/B). U205, under the control of range latch U210, switches the levels according to Table 10.3-3.

Table 10.3-3. U205 Control Signals

Frequency Range	EXT	R3
1 mHz - 999 kHz	1	0
1 MHz - 9.99 MHz	1	1
10 MHz - 50 MHz	0	1

Error Output

The error output is used during the HP 8116A self-test. It is not used during normal instrument operation.

Timing IC

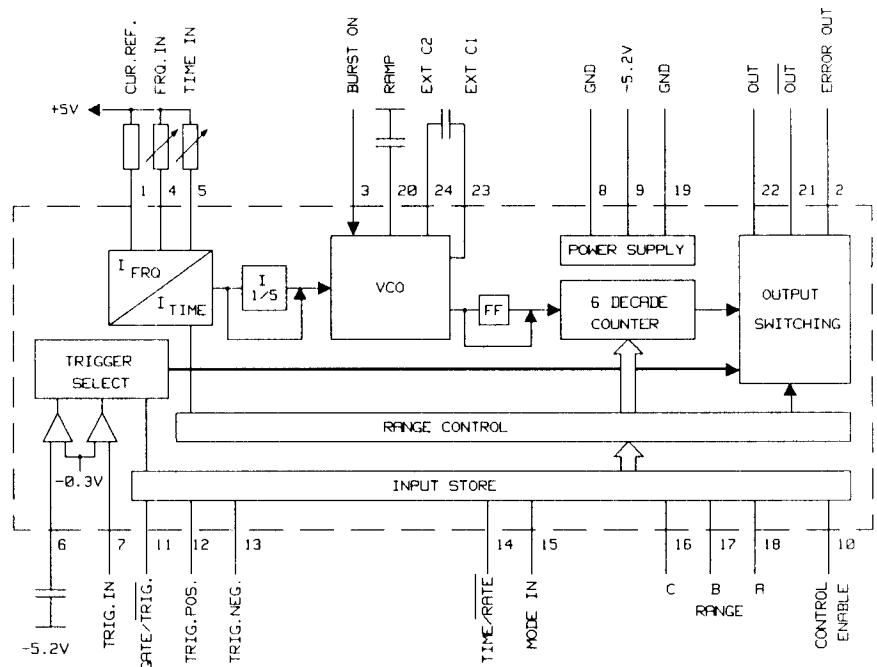

Figure 10.3-4. Timing IC block diagram

The timing IC U300 performs three distinct tasks in the HP 8116A:

- Triggerable pulse width generator (TIME Mode)
- Pulse width modulator (TIME Mode)
- Trigger source for Internal Burst mode (RATE Mode)

Refer to Figure 10.3-4 and Figure 10.3-7. The timing IC has an input store containing 8 control bits which control the mode of the IC:

Table 10.3-4. U300 Digital Control Signals

Pin	Name	Signal	Function
10	CONTROL ENABLE	$\overline{WS3}$	A positive TTL edge on this pin latches all the digital control signals into the input store.
11	GATE/ \overline{TRIG}	LD7	Selects trigger or gate
12	TRIG POS	LD6	Positive trigger
13	TRIG NEG	LD5	Negative trigger
14	TIME/ \overline{RATE}	LD4	Selects TIME or RATE mode
15	MODE	LD3	Always 0 in this application
16	RANGE C	LD2	Range selection, refer to Table 10.3-5
17	RANGE B	LD1	
18	RANGE A	LD0	

Table 10.3-5. Timing IC Range Selection

No.	C	B	A	RATE	TIME
0	0	0	0	10 MHz - 100 MHz	10 ns - 100 ns
1	0	0	1	1 MHz - 10 MHz	100 ns - 1 μ s
2	0	1	0	100 kHz - 10 MHz	1 μ s - 10 μ s
3	0	1	1	10 kHz - 100 kHz	10 μ s - 100 μ s
4	1	0	0	1 kHz - 10 kHz	100 μ s - 1ms
5	1	0	1	100 Hz - 1 kHz	1 ms - 10 ms
6	1	1	0	10 Hz - 100 Hz	10 ms - 100 ms
7	1	1	1	1 Hz - 10 Hz	100 ms - 1 s

TIME Mode

In TIME mode 8 pulse width ranges, from 10 ns to 999 ms, are selectable as shown in Table 10.3-5. Within each range the pulse width is controlled by the FRQ IN (Pin 4) current, derived from the width DAC on the control board A2, and the TIME IN (Pin 5) current, derived from the control input.

For triggered pulse-width generation (pulse output waveform), TIME mode is selected, with the appropriate width range, and then the width DAC sets the exact pulse width by setting the FRQ IN current only. The TIME IN current remains fixed at 0.2 mA. The trigger signal comes from the VCO (slope) IC trigger-output.

For pulse width modulation, TIME mode is also selected, with the appropriate width range, and then the control input sets the pulse width by controlling the TIME IN current. The FRQ IN current remains fixed at 0.2 mA.

RATE Mode

In RATE mode 8 output frequency ranges, from 1 Hz to 100 MHz, are selectable as shown in Table 10.3-5. The top range is not fully used in the HP 8116A.

In internal burst mode, RATE mode is selected. The RPT time determines the output frequency required from the timer IC. The microprocessor selects the appropriate frequency range and sets the exact frequency using the width DAC to set the FRQ IN current. The TIME IN current remains fixed at 0.2 mA. The output from the timing IC is used to trigger the VCO (slope) IC in internal burst mode.

Error Output

The width error output from the timing IC indicates that a trigger signal has been received before the completion of the previously triggered event.

P/O A1 MAIN BOARD

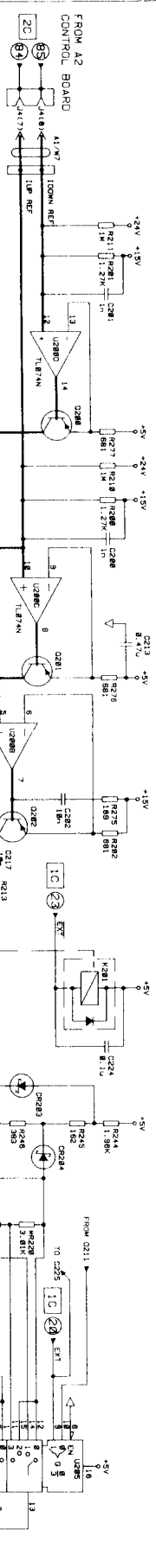

RANGE SWITCHING 10HZ

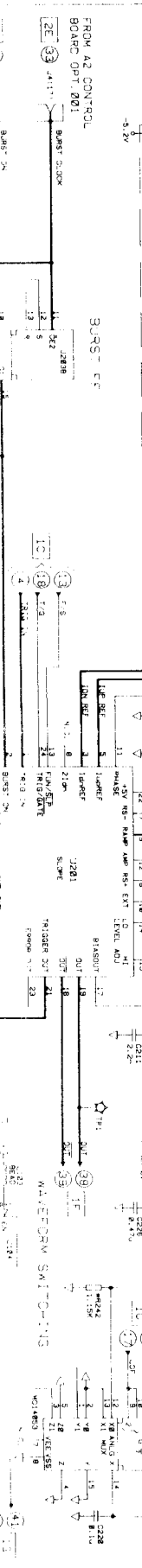
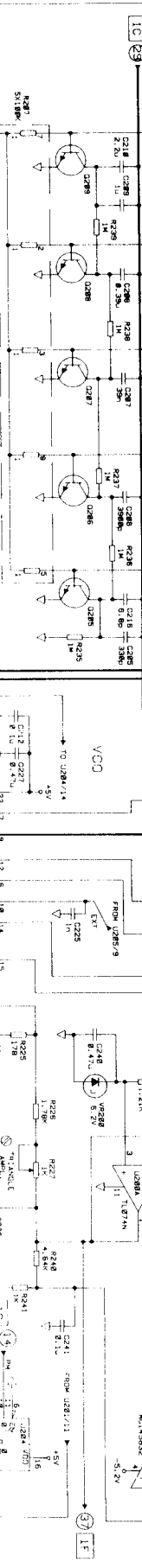
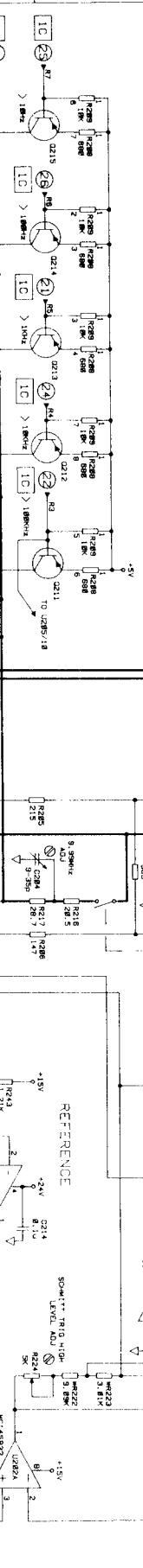

Troubleshooting

Note



- If an error code is being displayed by the HP 8116A you must press a key, **LCL** for example, to return the microprocessor to normal operation before troubleshooting.
- The component layout and locator for the main board A1 is at the end of Chapter 10.4.

Trigger-level Circuit and Amplifier

Check these circuits by applying an external signal of ± 5 V to the Trigger Input and testing the emitter of Q101 and pin 6 of U100 against Figure 10.3-8.

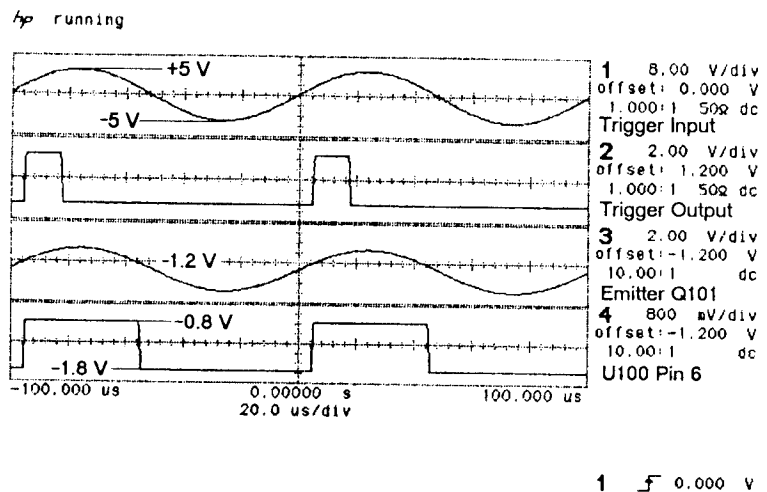

Figure 10.3-8. Trigger Input Amplifier signals

Control Mode Selection

Check the control-mode selection signals from control-latch U150 against Table 10.3-6:

Table 10.3-6. U150 Control Mode truth table

Control Mode	M3 Pin 9	M2 Pin 15	M1 Pin 12
Off	L	H	L
FM	L	L	H
AM	H	H	L
PWM	L	H	H
VCO	L	L	L

Frequency Range Selection

Check the frequency-range selection signals from range-latch U210 against Table 10.3-7:

Table 10.3-7. U210 Frequency Range truth table

No.	Frequency	EXT	$\overline{\text{EXT}}$	R3	R4	R5	R6	R7	$\overline{\text{LFR}}$
0	10.0 MHz – 50.0 MHz	L	H	H	H	H	H	H	H
1	1.00 MHz – 9.99 MHz	H	L	H	H	H	H	H	H
2	100 kHz – 999 kHz	H	L	L	H	H	H	H	H
3	10.0 kHz – 99.9 kHz	H	L	L	L	H	H	H	H
4	1.00 kHz – 9.99 kHz	H	L	L	L	L	H	H	H
5	100 Hz – 999 Hz	H	L	L	L	L	L	H	H
6	10.0 Hz – 99.9 Hz	H	L	L	L	L	L	L	H
7	1.00 Hz – 9.99 Hz	H	L	L	L	L	L	L	L
8	100 mHz – 999 mHz	H	L	L	L	L	L	L	L
9	10.0 mHz – 99.9 mHz	H	L	L	L	L	L	L	L
10	1.00 mHz – 9.99 mHz	H	L	L	L	L	L	L	L

Waveform Selection

Check the waveform selection signals from the trigger-mode latch U103 against Table 10.3-8:

Table 10.3-8. U103 Waveform truth table

Waveform	Mode	WF2	WF1
Sine, triangle, square	I.BUR	L	L
Sine, triangle, square	All except E.WID	L	H
Pulse	E.WID	H	L
Pulse	All except E.WID	H	H

VCO Set up the HP 8116A as follows:

Mode NORM
 Waveform Sine
 FRQ 1.00 kHz
 DTY 80%

Check the waveforms at TP1, TP2 and pin 12 of U201 against Figure 10.3-9 (Note that the signal at TP1 may not be symmetrical):

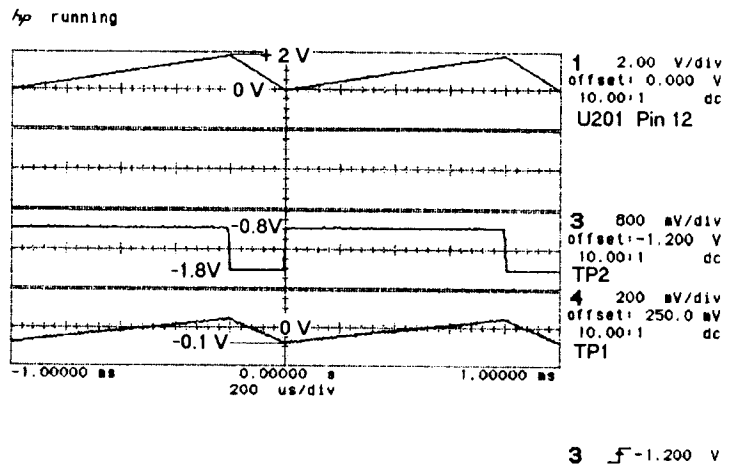

Figure 10.3-9. VCO Input and Output signals

Schmitt Trigger Levels

For frequencies up to 999 kHz the Schmitt-trigger levels are set at 0 V for the low level (U201 pin 14) and 2 V for the high level (U201 pin 15). Hence the timing-capacitor voltage on pin 12 of U201 varies between 0 and 2 V as shown in Figure 10.3-9.

If the levels are incorrect:

1. Switch off the HP 8116A.
2. Remove the VCO (slope) IC U201.
3. Switch on the HP 8116A and press **LCL** to reset error E21.
4. Check that the voltages supplied to pins 14 and 15 of U201's IC socket are correct.
5. If not, check the analog switch U205 against Table 10.3-9:

Table 10.3-9. U205 truth table

Frequency	R3	EXT	ON channels	
			Pin 3 to	Pin 13 to
1.00 mHz – 999 kHz	L	H	2	15
1.00 MHz – 9.99 MHz	H	H	4	11
10.0 MHz – 50.0 MHz	H	L	5	14

Iup Current Source

1. Set up the HP 8116A as follows:

Mode NORM
DTY 50%

2. Remove the VCO (slope) IC as described in "Schmitt Trigger Levels". Remember to press **LCL** to reset the error condition.

3. Connect a current meter between pin 9 of U201's socket and ground, then check the current values against Table 10.3-10.

Table 10.3-10.
 I_{up} , $I_{up\ ref}$ and $I_{down\ ref}$ currents at 50% duty-cycle

Frequency	Current
1.00 kHz	0.165 mA \pm 10%
5.00 kHz	0.830 mA \pm 10%
9.99 kHz	1.650 mA \pm 10%

$I_{up\ ref}$ Current Source

1. Set up the HP 8116A as follows:

Mode	NORM
DTY	50%

2. Remove the VCO (slope) IC as described in "Schmitt Trigger Levels". Remember to press **LCL** to reset the error condition.
3. Connect a current meter between pin 5 of U201's socket and ground, then check the current values against Table 10.3-10.

$I_{down\ ref}$ Current Source

1. Set up the HP 8116A as follows:

Mode	NORM
DTY	50%

2. Remove the VCO (slope) IC as described in "Schmitt Trigger Levels". Remember to press **LCL** to reset the error condition.
3. Connect a current meter between pin 3 of U201's socket and ground, then check the current values against Table 10.3-10.

Width Generator

Set up the HP 8116A as follows:

Mode	NORM
Waveform	Pulse
FRQ	100 kHz
WID	6.00 μ s

Check the signals at TP2, TP3 and pin 20 of U300 against Figure 10.3-10 (Note that the capacitance of the oscilloscope probe may change the width measured at pin 20 of U300).

hp running

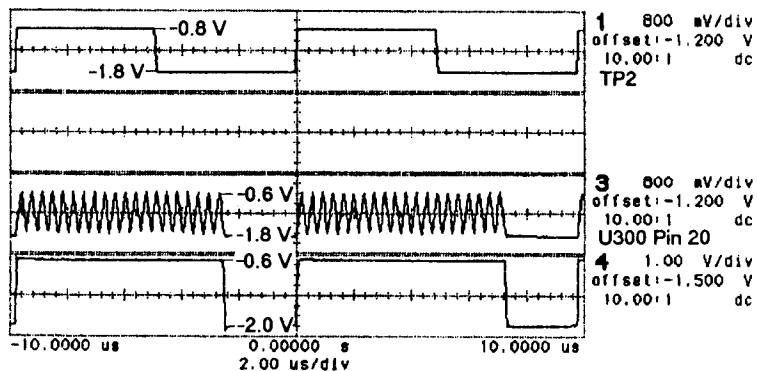

1 f -1.200 V

Figure 10.3-10. Width Generator Input and Output signals

Width Vernier Current

1. Set up the HP 8116A as follows:

Mode	NORM
Waveform	Pulse
FRQ	1.00 kHz
2. Measure the voltage at R308/C303 and check against Table 10.3-11.

Table 10.3-11. Voltage at R308/C303

Width	Minimum	Maximum
10.0 μ s	1.16 V	3.00 V
99.9 μ s	80 mV	300 mV

3. Check that pin 1, pin 4 and pin 5 of U300 are held at virtual ground (Minimum -40 mV, maximum 0 mV).

Servicing the Shaper and Output Amplifier

Theory of Operation

Introduction The shaper and output amplifier circuits are located on the main board A1 and are divided into the following parts:

- Shaper IC
- Amplitude Modulator
- Current Mirror
- Pre-Attenuator
- Signal Output Amplifier
- Output Attenuator
- Trigger Output Amplifier

These circuits are the last in the signal path.

Shaper IC The shaper IC U401, shown in Figure 10.4-1, is a high-performance signal-control circuit which operates either as a linear pre-amplifier or as a triangle-to-sine converter.

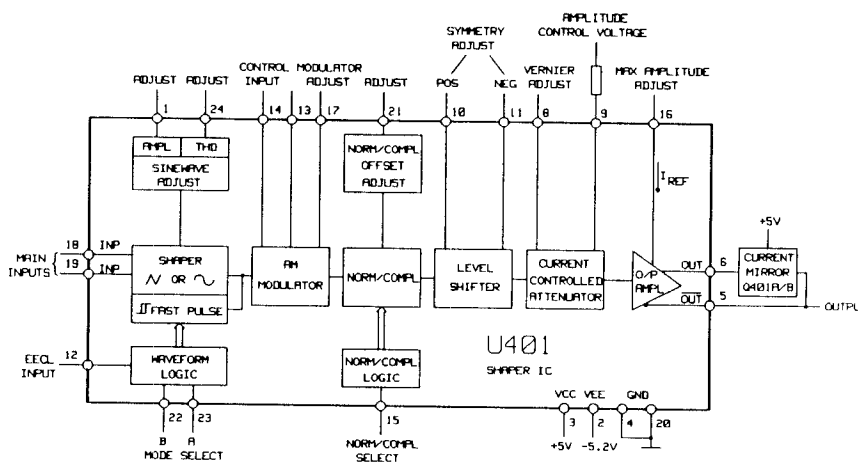

Figure 10.4-1. Shaper IC Block Diagram

The main inputs are differential current inputs. There is also a single-ended EECL voltage input (0 V to -0.6 V) which generates an output pulse with fast, but fixed, transition times.

The output waveform of the differential inputs is selected digitally by the mode-select inputs.

The amplitude modulator is controlled externally, refer to "Amplitude Modulator".

For all waveforms, normal or complement output is selected by digital input.

Amplitude Modulator

The amplitude modulator is controlled by two external signals. The first is the modulating signal itself (AM) which is derived from the external signal applied to the control input connector. The second is the TTL control signal M3 which is used to enable the modulating signal.

When M3 is high, as a result of selecting AM control mode at the frontpanel, the circuit operates as follows:

Transistor Q430 is switched off, Q431 base is biased towards the +5 V supply and follows the AM signal. Q431 emitter tracks the base potential and therefore Q432 turns on. Q432 and Q433 form the complementary amplifier stage of the circuit and ensure that the signal applied to the shaper IC has a current capability and offset proportional to its input amplitude.

Current Mirror

The differential output of the shaper IC requires a "current mirror" output stage which eliminates the effect of quiescent currents and doubles the available output signal. The operating principle is illustrated in Figure 10.4-2, and depends on Q1A and Q1B being a matched pair so that $I_a = I_b$.

In the HP 8116A Q1A = Q401A, Q1B = Q401B and Q2 = Q402. In triangle and sine waveforms Q403 is turned on, switching the R441/C406 combination into the current mirror in order to improve its performance.

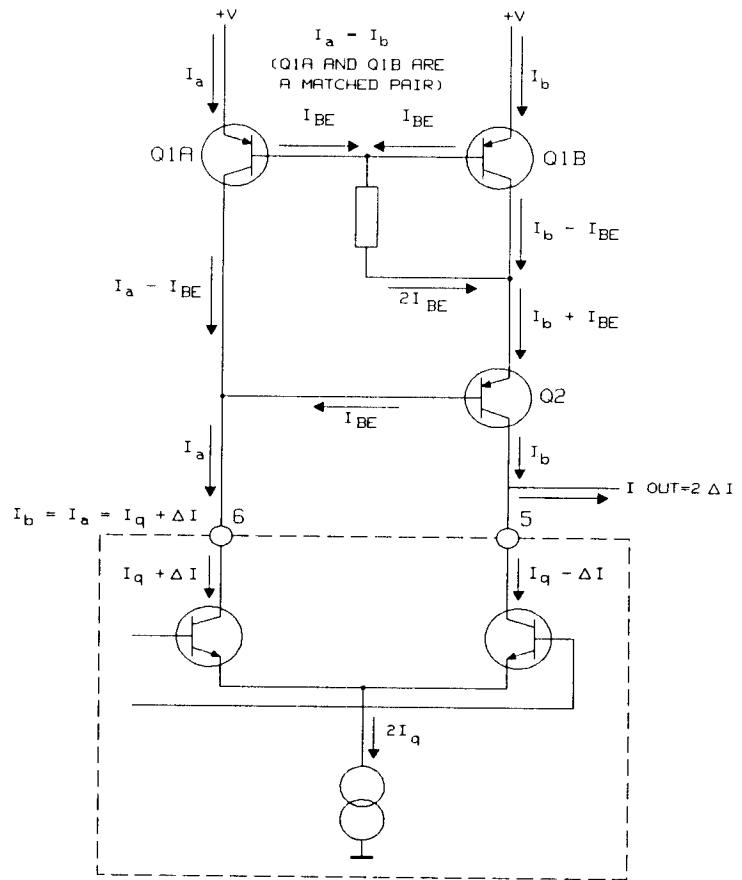

Figure 10.4-2. Current Mirror

Pre-Attenuator

The pre-attenuator circuit is controlled by the microprocessor via latch U503. Logic signals K1 – K4 control relays K501 – K504 to provide three levels of attenuation:

Table 10.4-1. Pre-attenuator ranges

Attenuation	Active Relay(s)	Final Output Range
0 dB	K501	16 V
4 dB	K502 & K504	9.99 V
24 dB	K503 & K504	0.99 V

Signal Output Amplifier

The output amplifier amplifies the signal received from the shaper IC via the pre-attenuator and adds the required offset voltage. A simplified version of the circuit is given in Figure 10.4-3

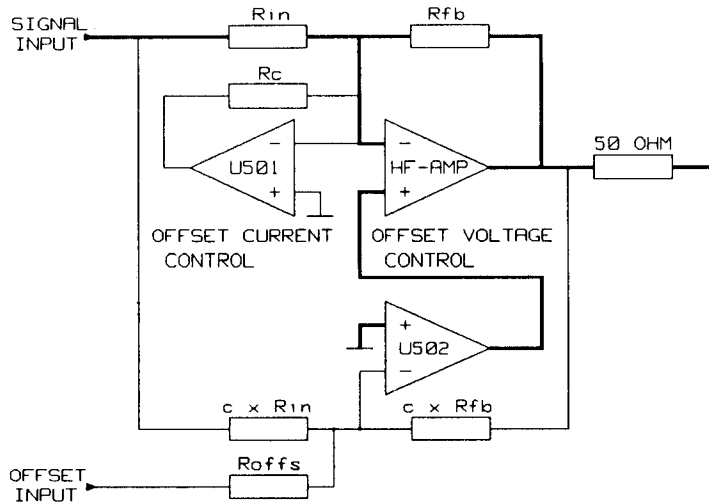

Figure 10.4-3. Simplified Output Amplifier circuit

The circuit is effectively an inverting amplifier with a voltage gain given by

$$Gain = \frac{R_{fb}}{R_{in}}$$

The main HF amplifier consists of the discrete transistors Q501 – Q513 and their related components on Figure 10.4-5.

The offset current error of the amplifier is compensated for by the offset-current control amplifier U501. This amplifier compares the virtual ground at the main-amplifier's inverting-input with actual ground and supplies a compensating current via R_c in order to maintain zero difference.

The offset-voltage control amplifier U502 detects any offset voltage at the main amplifier output, via the feedback network $c \times R_{in} / c \times R_{fb}$, and compensates for it via the main-amplifier's non-inverting input.

The required output-offset is created by injecting the offset-input signal from, the offset vernier DAC, into the summing point of the offset-voltage control amplifier via R_{offs} .

The main amplifier can be divided into three stages:

Input

The signal from the shaper IC current-mirror is applied to the inverting input where it is amplified by Q501 and Q502 (common base amplifiers). CR501 and CR502 provide the required bias voltages. The offset signal is applied to the non-inverting input at the junction of CR501, CR502 to ensure a constant reference point.

Voltage gain

The signals from the input stage, generated across R524 and R527, are applied to the bases of Q503 and Q504. These transistors operate as emitter followers for Q505 and Q506 which provide the actual voltage gain.

Output

The output stage consists of the emitter-follower pairs Q510, Q512 and Q511, Q513. These decouple the voltage gain stage from the low output-impedance.

Output Attenuator

The output attenuator provides 20 dB of attenuation while preserving the 50 Ω output impedance. The output signal is attenuated when K505 is switched off and K506 switched on. Note that the output is completely disabled when both relays are switched off.

Trigger Output Amplifier

The trigger amplifier is a current source designed to supply 2.4 V into 50 Ω (or 4.8 V into high impedance) when its output is high. Its input is driven from the timing IC or the VCO (slope) IC via multiplexor U104.

P/O A1 MAIN BOARD

OFFSET CURRENT COMPENSATION

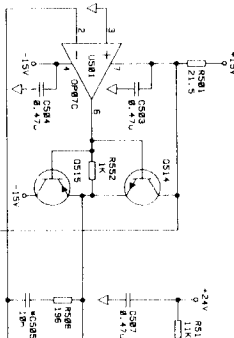

OFFSET VOLTAGE CONTROL

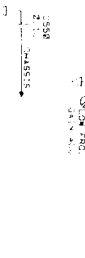

*R559, *C539 NOT NORMALLY FITTED
*C558 FITTED TO THE NON-COMPONENT SIDE OF THE BOARD WHEN RECALIBRED

OUTPUT AMPLIFIER

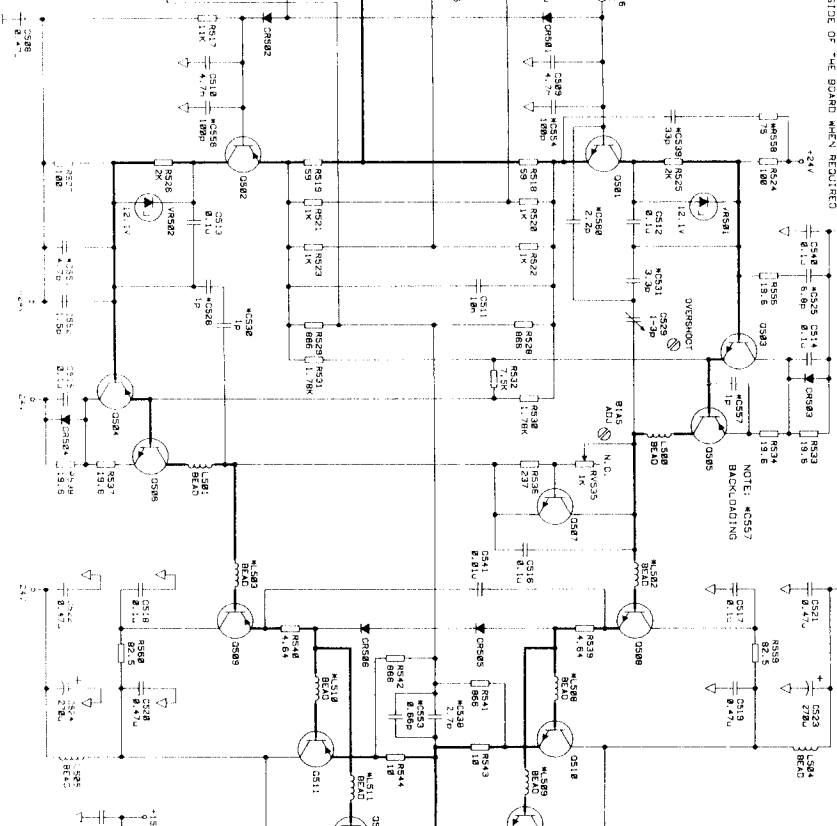

NOTE: *C557 BACKLOADING

TRIGGER OUTPUT AMPLIFIER

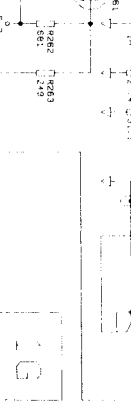
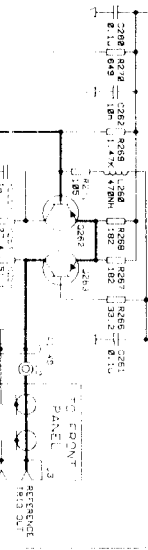

WORD: H9B1164
FIGURE 12-4-5
MAIN BOARD A1-COMPARATOR
SERVICING THE SHAPER AND OUTPUT AMPLIFIER 12-4-5



Troubleshooting

Note



- If an error code is being displayed by the HP 8116A you must press a key, **LCL** for example, to return the microprocessor to normal operation before troubleshooting.
- The component layout and locator for the main board A1 is at the end of this chapter.

Shaper IC Inputs

1. Set up the HP 8116A as follows:

Mode	NORM
Waveform	Triangle
FRQ	1.00 kHz
AMP	999 mV
OFS	0 V

2. Use an oscilloscope to check the signals at pins 18 and 19 of U401 and TP4 against Figure 10.4-6. Note that the signals on pins 18 and 19 are not necessarily symmetrical.

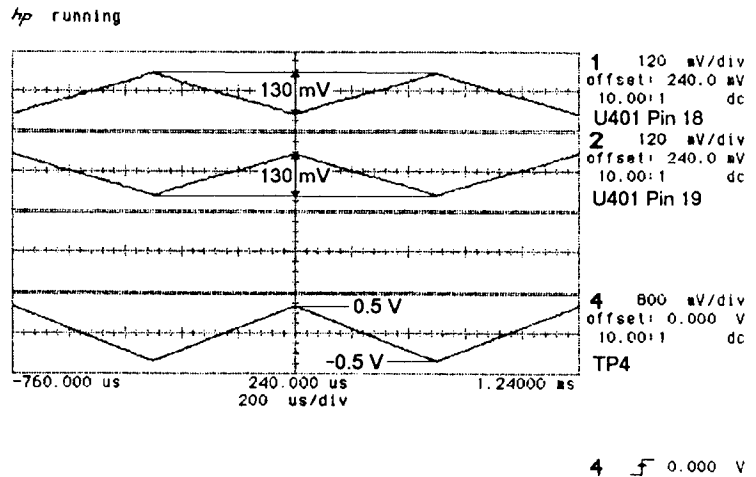

Figure 10.4-6. Shaper IC Input and Output (Sine/Triangle)

3. Set the HP 8116A amplitude to 9.99 V and repeat the check.
4. Set the HP 8116A amplitude to 16.0 V and repeat the check.
5. Set up the HP 8116A as follows:

Mode	NORM
Waveform	square
FRQ	1.00 kHz
AMP	999 mV
OFS	0 V

- Use the oscilloscope to check the signals at pin 12 of U401 and TP4 against Figure 10.4-7.

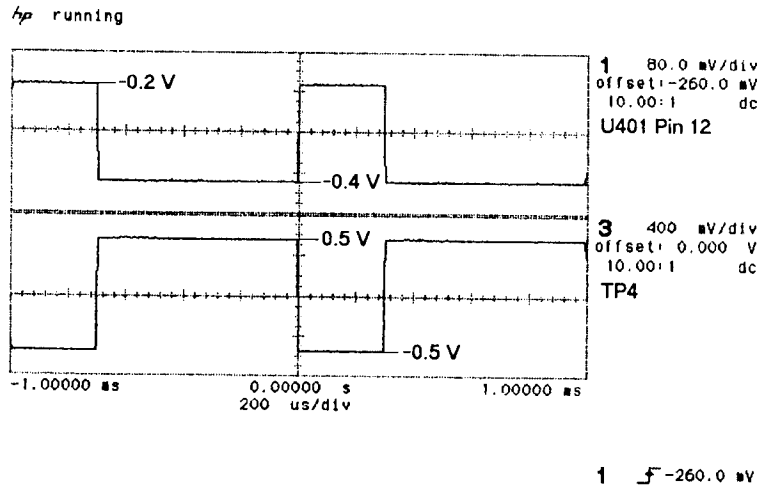

Figure 10.4-7. Shaper IC Input and Output (Square/Pulse)

- Set the HP 8116A amplitude to 9.99 V and repeat the check
- Set the HP 8116A amplitude to 16.0 V and repeat the check.

Shaper IC Amplitude-vernier Control-voltage

With the HP 8116A offset set to 0 V, check the amplitude-vernier control-voltage for the amplitude settings given in Table 10.4-2. The voltage is measured at the junction of R422, R450 and R445.

Table 10.4-2. Amplitude-vernier Control-voltages

Amplitude setting	Control voltage at R422, R450
1.00 V	7.95 V \pm 10%
5.00 V	4.40 V \pm 10%
9.99 V	< 30 mV

Shaper IC Reference Current

- Switch off the HP 8116A.
- Remove the shaper IC U401.
- Switch on the HP 8116A and press the **LCL** key to clear error E51.
- Connect a current meter between pin 16 of U401's IC socket and ground.
- Check that the current is approximately 2.5 mA.
- Switch off the HP 8116A before replacing the shaper IC.

**Shaper IC
Current-mirror**

Check that the signal levels at the emitters of Q401A and Q401B are identical, as these transistors are a matched pair.

**Pre-Attenuator and
Output Attenuator
Control Signals**

Check the relay control signals K1 – K6 against Table 10.4-3:

Table 10.4-3. Attenuator Control truth table

Amplitude range	K1	K2	K3	K4	K5	K6
10.0 V – 16.0 V	L	H	H	H	L	H
1.00 V – 9.99 V	H	L	H	L	L	H
100 mV – 999 mV	H	H	L	L	L	H
10.0 mV – 99.9 mV	H	H	L	L	H	L
Waveform Off (>100 mV)	H	H	L	H	L	H
Output Disabled	X	X	X	X	H	H

**Offset-vernier
Control-voltage**

1. Set the HP 8116A amplitude to 100 mV
2. Check the offset-vernier control-voltage, received from the control board A2 at the junction of R508, C501, against Table 10.4-4:

Table 10.4-4. Offset-vernier Control-voltages

Offset setting	Control voltage at R508, C501
-7.95 V	+3.20 V ±50 mV
-5.00 V	+2.00 V ±50 mV
0 V	0 V ±20 mV
+5.00 V	-2.00 V ±50 mV
+7.95 V	-3.20 V ±50 mV

Output Amplifier

Caution



-
- Do not operate the HP 8116A without the heatsinks fitted on board A1
 - If you need to replace one or more of the transistors Q505 – Q513, *do not attempt to remove the heatsink and transistor adaptors together, this is likely to damage the transistors.*
 1. Remove all the screws securing the heatsink(s).
 2. Remove the heatsink(s).
 3. Remove the adaptor(s) from the transistor(s) to be replaced.
 4. Replace the transistor(s).
 5. Re-fit the adaptor(s) and heatsink(s).
-

1. Set up the HP 8116A as follows:

Waveform	Off
OFS	0 V
2. Measure the voltage at CR501 and CR502:

If it is fully negative (approximately -15 V) check U502, Q502, Q504 and Q506.

If it is fully positive (approximately +15 V) check Q501, Q503, Q505 and U502.
3. Check if Q510/Q511 or Q512/Q513 have failed (emitter-collector short-circuit).

If you need to change any of the output-stage transistors Q508 – Q513, also check CR505 and CR506. They protect the output stage at high amplitudes and frequencies by discharging the base-emitter capacitor of Q510 –Q513.
4. Set the HP 8116A to a high output amplitude and square waveform.
5. Observe the main output using an oscilloscope and check the edges for distortion.

If there is distortion, check the output-amplifier input signal at TP4.

If the input signal is clean and the leading edge of the output signal is distorted, check Q503 and Q505.

If the input signal is clean and the trailing edge of the output signal is distorted check Q504 and Q506.

REF. DES.	GRID LOC.	REF. DES.	GRID LOC.	REF. DES.	GRID LOC.	REF. DES.	GRID LOC.	REF. DES.	GRID LOC.	REF. DES.	GRID LOC.	REF. DES.	GRID LOC.	REF. DES.	GRID LOC.	REF. DES.	GRID LOC.
C1	B2	C301	C1	CR101	C1	Q201	B2	R30	A2	R224	C2	R420	C2	R544	D1	W2	B2
C2	B2	C302	C1	CR151	C1	Q202	B2	R31	A1	R225	C2	R421	C2	R545	D1	W3	B2
C3	A2	C303	C1	CR152	C1	Q203	B2	R32	A2	R226	C2	R422	C2	R546	D1	W4	B2
C4	A2	C304	C1	CR153	C1	Q204	B2	R33	A2	R227	C2	R423	C2	R547	D1	W5	B2
C5	A2	C306	C1	CR154	C1	Q205	B2	R34	A1	R228	C2	R424	C2	R548	D1	W7	B2
C6	B2	C307	C1	CR203	C2	Q206	B2	R35	A1/2	R229	C2	R425	C2	R549	D1	W8	D1
C7	A1	C400	C2	CR204	C2	Q207	B2	R36	A1/2	R230	C2	R426	C2	R550	D1	W9	B1
C8	A1	C401	C2	CR300	C1	Q208	B2	R37	A1	R231	C2	R427	C2	R551	C1	W10	C1
C9	A1	C402	C2	CR301	C1	Q209	B2	R38	A1	R232	C2	R428	C2	R552	D2	W11	B2
C10	A1	C403	C2	CR302	C1	Q210	B2	R39	A1	R233	C2	R430	C1	R553	D1	W15	B2
C11	B1	C404	C2	CR303	C1	Q211	B1	R40	A1	R234	C2	R431	C1	R554	D1	W16	B2
C12	B1	C405	C2	CR304	C1	Q212	B1	R41	A1	R235	B2	R432	C1	R555	D2		
C13	B1	C406	C2	CR401	C2	Q213	B1	R42	A1	R236	B2	R433	C2	R556	D2		
C14	A2	C408	C2	CR402	C2	Q214	B1	R43	A1	R237	B2	R434	C2	R558	D2		
C15	A2	C409	C2	CR501	D2	Q216	B2	R44	A1	R238	B2	R435	C2	R559	D1		
C16	A2	C410	C2	CR502	D2	Q220	B2	R45	A1	R239	B2	R436	C2	R560	D1		
C17	A2	C501	D2	CR503	D2	Q260	B1	R46	A1	R240	C2	R437	D2	R561	C1		
C18	B2	C502	D2	CR505	D1	Q261	B1	R47	A1	R241	C1	R438	C1	R590	C1		
C19	B2	C503	D2	CR506	D1	Q262	B1	R48	A1	R242	C1	R439	C2	R591	C1		
C20	A1	C504	D2			Q263	B1	R100	B2	R243	B2	R440	C2	R592	C1		
C21	A1			CR513	D1												
C100	D2	C505	D2	CR514	D1	Q300	C1	R101	B1	R244	C2	R441	C2	R593	D1		
C101	B1	C506	D2			Q301	C1	R102	B1	R245	C2	R445	C2	R594	D1		
C102	B1	C507	D2	J1	B2	Q302	C1	R103	B1	R246	C2	R446	C2				
C103	B2	C508	D2	J2	C1	Q303	C1	R104	B1	R260	B1	R448	C2	S1	B2		
C104	B1	C509	D2	J3	B1	Q401	C2	R105	B1	R261	B1	R449	C2				
C105	B1	C510	D2			Q402	C2	R106	D2	R262	B1	R450	C2	TP1	C2		
C106	D2	C511	D2	K201	C2	Q403	C2	R107	B1	R263	B1	R451	C2	TP2	C2		
C107	B2	C512	D2	K202	B2	Q430	C1	R108	B1	R264	B1	R452	C2	TP3	C1		
C108	C2	C513	D2	K501	D2	Q431	C2	R109	B1	R265	B1	R453	C2	TP4	C2		
C109	C2	C514	D2	K503	D2	Q432	C2	R110	B1	R266	B1	R454	C2				
C110	B1			K504	D2												
C112	B2	C515	D2	K505	D1	Q433	C1	R111	B1	R267	B1	R501	D2	U1	A1		
C113	B2	C516	D1	K506	D1	Q501	D2	R112	B1	R268	B1	R502	D2	U2	A1		
C114	B2	C517	D1			Q502	D2	R113	B1	R269	B1	R503	D2	U3	A1		
C115	B2	C518	D1			Q503	D2	R114	B1	R270	B1	R504	D2	U4	A1		
C151	C1	C519	C1	L100	B1	Q504	D2	R115	B1	R271	B1	R505	D2	U5	A1		
C152	C1	C520	D1	L101	B1									U6	A1		
C153	C1	C521	C1	L102	B1	Q505	D1	R116	B1	R272	B2	R506	D2	U7	A1		
C154	C1	C522	D1	L103	C2	Q506	D1	R117	B1	R273	B1	R507	D2				
C200	B2	C523	C1	L260	B1	Q507	D1	R118	B1	R274	B2	R508	D2	U100	B1		
C201	B2	C524	D1	L300	C1	Q508	D1	R119	C1	R275	B2	R509	D2	U101	B1		
C202	B2	C525	D1	L301	C2	Q509	D1	R120	C1	R276	B2	R510	D2	U102	B1		
C204	B2	C526	D1	L500	D1	Q510	D1	R121	C1	R277	B2	R511	D2	U103	B1		
C205	B2	C527	D1	L501	D1	Q511	D1	R122	C2	R300	C1	R512	D2	U104	C2		
C206	B2	C528	D1	L502	D1	Q512	D1	R123	C2	R301	C1	R513	D2				
C207	B2	C529	D1	L503	D1	Q513	D1	R124	C2	R302	C1	R514	D2	U110	B1		
C208	B2	C530	D1	L504	D1	Q514	D2	R125	B1	R303	C1	R515	D2	U150	C1		
C209	B2	C531	D2	L505	D1	Q515	D2			R304	C1	R516	D2	U151	C1		
C210	B2	C532	D2	L506	C2	Q590	C1	R130	C1	R305	C1	R517	D2	U152	C1		
C211	C2	C533	D2	L507	C2	Q591	C1	R150	C1	R306	C1	R518	D2	U200	B2		
C212	C2	C534	C2	L508	D1	R1	A1	R151	C1	R307	C1	R519	D2				
C213	B2	C535	C2	L509	D1	R2	A1	R153	C1	R308	C1	R520	D2	U201	C2		
C214	B2	C536	D2	L510	D1	R3	A1							U202	C2		
C215	C2	C537	D2	L511	D1	R4	A1	R154	C1	R309	C1	R521	D2	U203	C2		
C216	B2	C538	D1			R5	A1	R155	C1	R310	C1	R522	D2	U204	C1		
C217	B2	C539	D2	MP1	A1			R157	C1	R311	C1	R523	D2	U205	C2		
C220	C2	C540	D2	MP2	A1	R6	A1	R158	C1	R400	D2	R524	D2				
C221	C2	C541	D1	MP3	A1	R7	A1	R200	B2	R401	D2	R524	D2	U210	B1		
C222	C2	C550	D2	MP4	C2	R8	A1			R402	C2	R525	D2	U300	C1		
C223	C2	C551	D2	MP100	D2	R9	A1	R201	B2	R403	C2	R526	D2	U301	C1		
C224	C2	C552	D2			R10	A1	R202	B2	R404	C2	R527	D2	U302	C1		
C225	C2	C553	D1	MP200	B1	R11	A1	R204	C2	R405	C2	R528	D2	U400	C2		
C226	C2	C554	D2	MP201	C2	R12	A1	R205	C2	R406	C2	R529	D2				
C227	C2	C555	D2	MP300	C1	R13	A1	R206	C2					U401	C2		
C230	C2	C556	D2	MP401	C2	R14	A1	R207	B1	R407	C2	R530	D2	U501	D2		
C231	C2	C557	D1	MP500	D1	R15	A1	R208	B1	R408	C2	R531	D2	U502	D2		
C235	C2	CR1	B2	Q1	A1	R16	A1	R209	B1	R409	C2	R532	D2	U503	C1		
C240	B2	CR2	A2	Q2	A1	R17	A1	R210	B2	R410	C2	R533	D1/2				
C241	C1	CR3	A2	Q3	A1	R18	A1	R211	B2	R411	C2	R534	D1/2	VR1	A1		
C260	B1	CR4	A1	Q4	A1	R19	A1	R213	C2	R412	C2	R535	D1	VR2	A1		
C261	B1	CR5	A1	Q5	A1	R20	A2	R215	B2	R413	C2	R536	D1	VR3	A1		
C262	B1	CR6	A1	Q6	A1	R21	A2	R216	B2	R414	C2	R537	D1/2	VR200	B2		
C263	B1	CR7	A1	Q7	A1	R22	A1	R217	B2	R415	C2	R538	D1/2	VR501	D2		
C264	B1	CR8	A1	Q8	A1	R23	A1	R219	C2	R416	C2	R539	D1				
C300	C1	CR9	A1	Q100	B1	R24	A1	R220	C2					VR502	D2		
		CR10	A1	Q101	B1	R25	A1	R221	C2	R417	C2	R540	D1	VR504	D1		
		CR11	A1	Q102	C1	R26	A1	R222	C2	R418	C2	R541	D1	VR505	D1		
		CR12	A1	Q200	B2	R27	A1	R223	C2	R419	C2	R542	D1				
						R28	A1			R419	C2	R543	D1				

FIGURE 10.4-9. MAIN BOARD A1 COMPONENT LOCATOR
SERVICING THE SHAPER AND OUTPUT AMPLIFIER 10.4-17

Servicing the Standard Control Board

Theory of Operation

- Introduction** The main function of the control board A2 is to convert digital control data into analog control signals used on the main board A1. The main board supplies power to the control board and the microprocessor board A3 supplies the digital control data. The standard control board is divided into the following areas:
- Timer circuit
 - Address decoders
 - -9 V Reference circuit
 - Digital to Analog Converters (DACs)
 - Offset and Amplitude circuits
 - Width Vernier Current Source
 - Up and Down Current Sources (Frequency and duty-cycle circuits)
 - Capacitance Amplifier
- Timer** Refer to Figure 10.5-5. The timer circuit is an astable multivibrator which produces an output of approximately 100 Hz when enabled by RESET and the input to pin 4. The output is used to generate $\overline{\text{NMI}}$ which interrupts the microprocessor and makes it jump to an error subroutine where it illuminates the error display.
- Address Decoders** Refer to Figure 10.5-5. Local address decoding is performed by U14 and U20. Both decoders share LA3—LA5 from the microprocessor board as address inputs, $\overline{\text{WS5}}$ enables decoder U14 and $\overline{\text{WS8}}$ enables decoder U20. The decoder outputs enable the various devices on the latched-data bus LD0—LD7.
- 9 V Reference Circuit** Refer to Figure 10.5-6. The -9 V reference is used by the amplitude, offset, and width-vernier current source DACs. It is derived from a unity-gain inverting amplifier (U5B) and provides a constant current.

Digital to Analog Converters

Normal operation

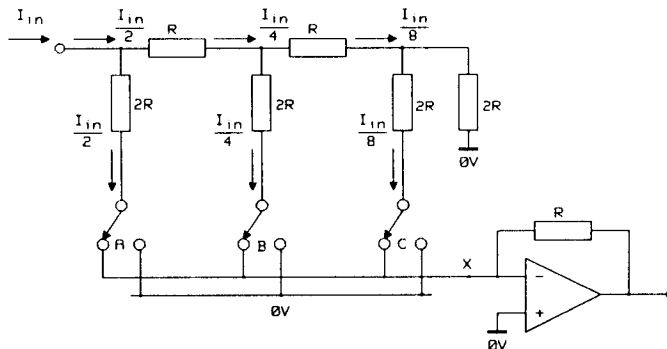

Figure 10.5-1. Principle of DAC Operation

The amplitude, frequency and offset DACs (U27, U6 and U24) operate on the principle summarised in Figure 10.5-1. The current I_{in} comes from a reference voltage and is repeatedly divided by two at each branch of the resistance network. This process provides a series of binary current-fractions which are switched to ground or the summing point X. Each switch is operated by the data bit which has the same significance as the current it controls (A=Most Significant Bit). The total current summed at X therefore represents the data value as a fraction of I_{in} . For example, in Figure 10.5-1 with all three switches on (all three data bits on):

$$I_X = \frac{I_{in}}{2} + \frac{I_{in}}{4} + \frac{I_{in}}{8} = \frac{7}{8}I_{in}$$

Reciprocal operation

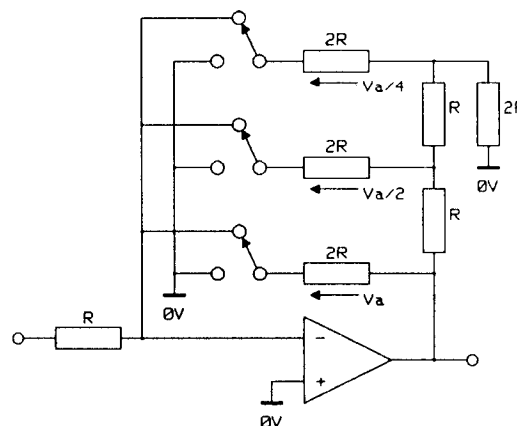

Figure 10.5-2. DAC - Reciprocal operation

The width-vernier current-source and duty-cycle DACs operate in a similar fashion but are set up to produce an output which is the

reciprocal of the input value. Refer to Figure 10.5-2. The currents summed at the inverting input of the op-amp can be expressed as:

$$\frac{V_a}{2R} + \frac{V_a}{4R} + \frac{V_a}{8R} = -\frac{V_{ref}}{R}$$

Therefore:

$$V_a = -\frac{8}{7}V_{ref}$$

Offset and Amplitude circuits

Refer to Figure 10.5-6 and Figure 10.5-1. The offset DAC U24 is a 12-bit multiplying device which provides two output currents. I_{out1} is the summed current derived from the reference voltage via the selected $\frac{R}{2R}$ networks. (I_X in "Digital to Analog Converters"). I_{out2} is the sum of the unselected currents and hence:

$$I_{out1} + I_{out2} = I_{in}$$

U24 has no internal latches and, since the DAC output must be available continuously and simultaneously with the amplitude DAC output, external latches are provided (See Figure 10.5-5). The low and high bytes of the offset value are loaded separately from the latched-data bus into latches U23 and U21 using \overline{LBO} and \overline{HBO} to enable the latches. The \overline{SCA} ($\overline{WS4}$) signal is then used to pass the data to U24 via U43 and U22. The \overline{SCA} signal is also inverted by U19F and used to enable the amplitude DAC U27. Therefore the microprocessor can prepare new data for U24 and U27 before enabling both with \overline{SCA} . The time difference between \overline{SCA} , enabling U27, and \overline{SCA} , enabling new data for U24, is the propagation delay through U19.

The offset level output from U26 can be attenuated using R45. The microprocessor switches R45 in or out of the circuit by using the OFFS signal to control switch Y in U17.

Width Vernier Current Source

Refer to Figure 10.5-7. The width vernier DAC operates as a reciprocal DAC, as described in "Digital to Analog Converters". The output current passes through one of two resistance paths selected by switch Z of U17 using COMP2. The signal then goes to the analog decoder section of the Timing IC on the main board A1.

Up and Down Current Sources

Refer to Figure 10.5-3 and Figure 10.5-7. The up and down constant-current sources are used by the VCO (slope) IC U201 on the main board. The up-current charges a timing capacitor up to a threshold voltage and then the down-current discharges it. Therefore the sum of the currents defines the period, and the ratio of the currents defines the duty-cycle.

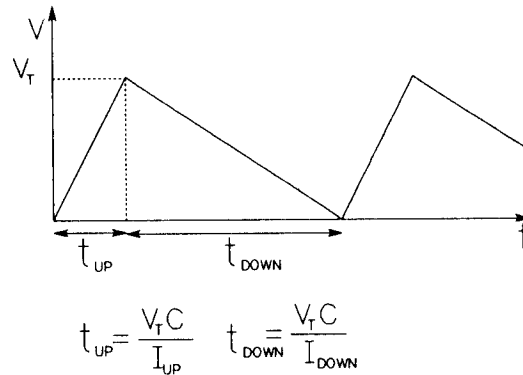

Figure 10.5-3.
Ramp generation by charging and discharging a capacitor with constant currents

The output of the frequency DAC (U6,U7 in Figure 10.5-6) is the reference input for both the up and down duty-cycle DACs. Therefore when the frequency data changes, both the up- and down-currents change in the same proportion and the output frequency changes without changing the duty cycle.

At 50% duty-cycle the up- and down-currents are identical so that the capacitor charges and discharges at the same rate. To achieve 20% duty cycle the microprocessor adjusts the up-DAC and down-DAC so that the up- and down-currents are in the ratio 80% : 20%, but their sum remains constant. This means the capacitor charge time is now 20% of the period, but the period remains constant.

Capacitance Amplifier

Refer to Figure 10.5-5. The capacitance amplifier allows the effective capacitance of a capacitor to be changed according to the formula:

$$C_{eff} = \frac{R1}{R2}(g - 1)C$$

A simplified version of the circuit is given in Figure 10.5-4. In the HP 8116A the microprocessor varies R1 using latch U3 and relays K1—K4.

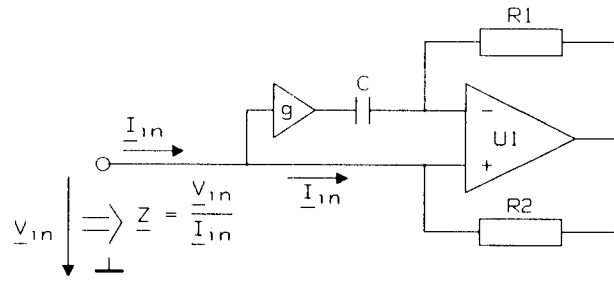

Figure 10.5-4. Simplified Capacitance Amplifier

The capacitance amplifier provides the large capacitances needed by the VCO (slope) IC U201 to achieve frequencies < 10 Hz (See “Up and Down Current Sources”). The capacitors required for higher frequencies are located on the main board.

P/O A2 CONTROL BOARD

ADDRESS DECODER OUTPUT

TIMING COMP/HIGH
BYTE BURST

CAPACITANCE AMPLIFIER

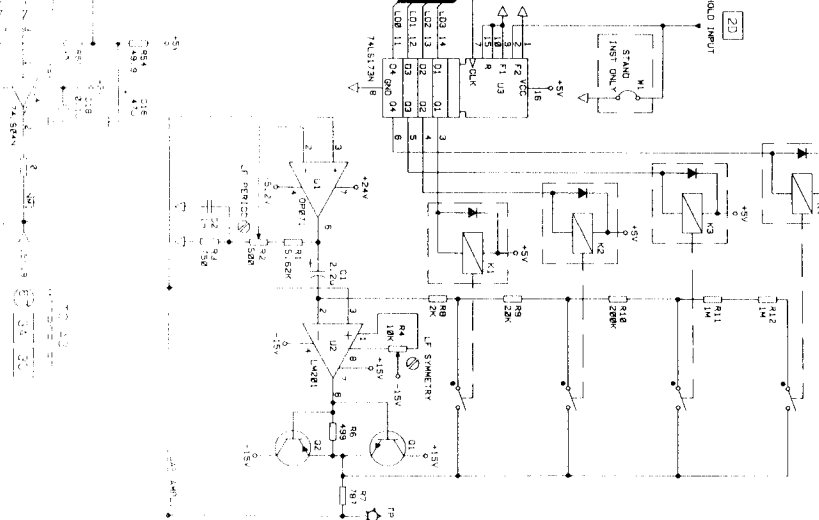
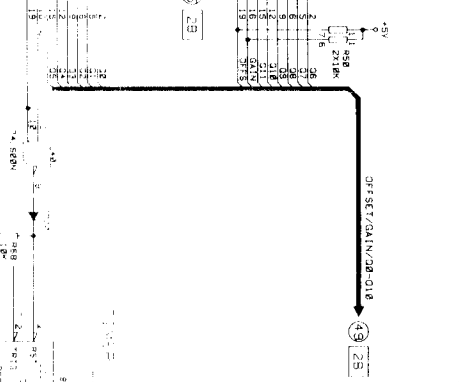
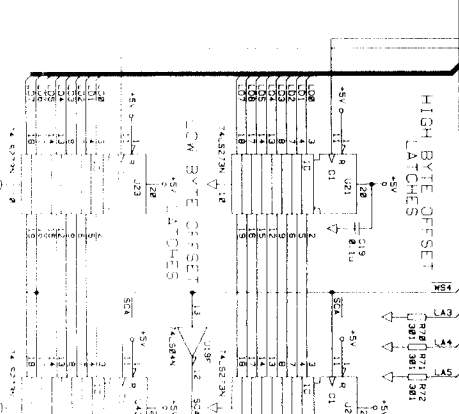
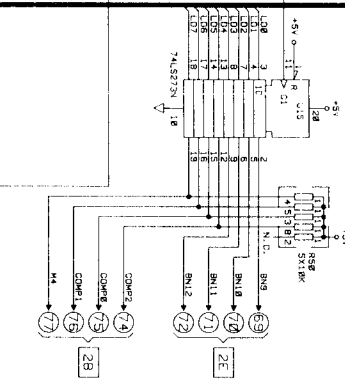
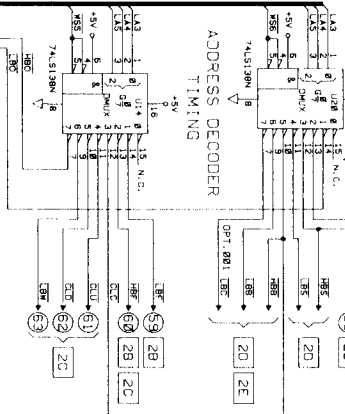
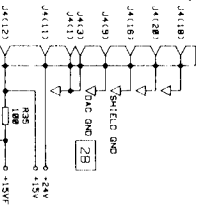

TO A1 MAIN BD (10)

W02L-081164

102-06 101-01

CONTROL BOARD BOARDWATER

REVISION 49 STANDARD CONTROL BOARD

102-06 101-01

102-06 101-01

102-06 101-01

P/O A2 CONTROL BOARD

1 2 3 4

REV 1.0E

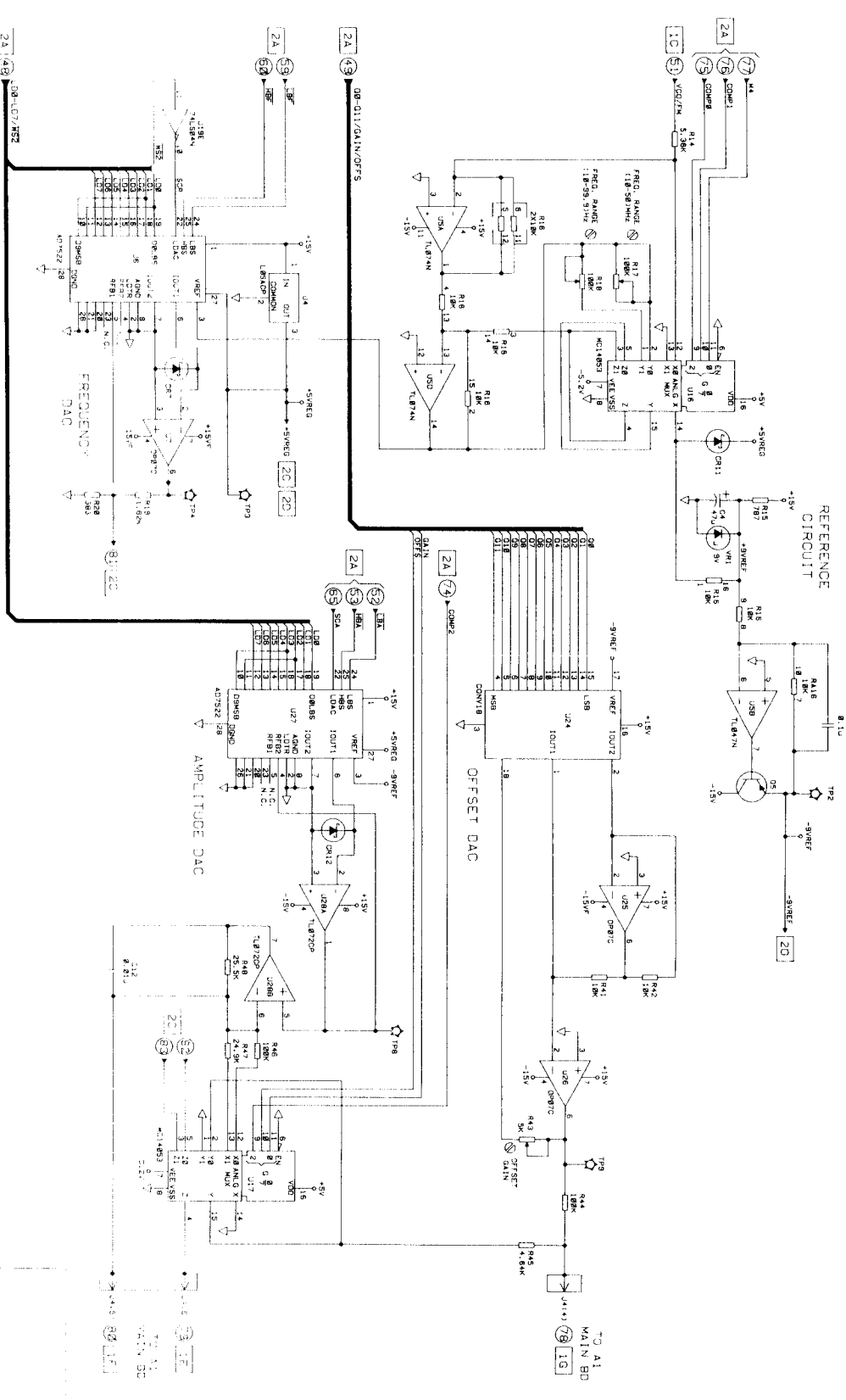

WORLDWIDE
 DISTRIBUTION
 CONTACT: 800-541-5555
 WWW.MOTOROLA.COM

2B

Troubleshooting

Note



- If an error code is being displayed by the HP 8116A you must press a key, **LCL** for example, to return the microprocessor to normal operation before troubleshooting.
- The component layout and locator for the standard control board A2 is at the end of the chapter.

Timer

1. Set up the HP 8116A as follows:

Waveform	Sine
Control	E.WID

2. Check that pin 3 of U31 is delivering a signal of approximately 100 Hz.

Address Decoders

The address decoders can be checked using signature analysis:

1. Set the microprocessor to free-run as described in “Free Running Signature Analysis” in Chapter 10.7, except *keep A2W2 connected*. Then connect the signature analyzer probes to the microprocessor board as given in Table 10.7-2.
2. Connect the data probe to the microprocessor’s +5 V supply and check that the signature is 0003. If not, the microprocessor is not free-running.
3. Use the data probe to check the signatures of U14, U19 and U20 against Table 10.5-1.

Table 10.5-1.
Signatures for Control Board Address Decoders

Pin	U14	U19	U20
1	P50H		P50H
2	CH9U		CH9U
3	8759		8759
4	8U95		1FH6
5	8U95	FU39	1FH6
6		FU3A	
7	F2F2		FU39
8		79HF	
9	0F4F	79HU	H456
10	71P0	PU9A	11AF
11	58F8	PU99	8392
12	27A6	55F7	508P
13	F491	55F4	04H5
14	P10H		8UP5

Frequency Control

1. Check that U16 operates according to the following table:

Table 10.5-2. U16 Frequency Range Selection

Frequency Range	Pin 10 COMP1	Pin 9 COMP2	ON channels	
			Pin 15 to:	Pin 4 to:
1.00 mHz – 99.9 Hz	H	L	Pin 1	Pin 5
100 Hz – 9.99 MHz	H	H	Pin 1	Pin 3
10.0 MHz – 50.0 MHz	L	L	Pin 2	Pin 5

2. For the following frequencies check the frequency DAC output-voltage at TP4:

Table 10.5-3. Frequency DAC - Output Voltages

Frequency	Voltage at TP4
1 kHz	-0.44 V \pm 10%
5 kHz	-2.20 V \pm 10%
9.99 kHz	-4.39 V \pm 10%

Duty Cycle Control

1. Set up the HP 8116A as follows:

Waveform	Sine
FRQ	9.99 kHz

2. Check the duty-cycle DACs' output-voltages against the following table:

Table 10.5-4. Duty-Cycle DACs - Output Voltages

Duty Cycle	Voltage at TP5	Voltage at TP6
10%	10.1 V \pm 15%	1.1 V \pm 15%
50%	2.0 V \pm 15%	2.0 V \pm 15%
90%	1.1 V \pm 15%	10.1 V \pm 15%

Width Control

1. Set up the HP 8116A as follows:

Waveform	Pulse
FRQ	1 kHz

2. Check the width vernier DAC's output-voltage against the following table:

Table 10.5-5. Width Vernier DAC - Output Voltages

Width	Voltage at TP7
10.0 μ s	9.9 V \pm 10%
50.0 μ s	2.0 V \pm 10%
99.9 μ s	1.0 V \pm 10%

Table 10.5-9. Offset DAC - Output Voltages

Offset	Voltage at TP9	Input Data												Decimal
		Q11	Q10	Q9	Q8	Q7	Q6	Q5	Q4	Q3	Q2	Q1	Q0	
+7.95 V	-7.35 V ±20%	0	0	0	1	1	1	0	0	1	0	1	0	458
+5.12 V	-4.70 V ±20%	0	1	0	0	0	0	0	0	0	0	0	0	1024
+1.00 V	-0.92 V ±20%	0	1	1	1	0	0	1	1	1	0	0	0	1848
+999 mV	-9.22 V ±20%	0	0	0	0	0	0	1	1	0	0	1	0	50
+100 mV	-0.92 V ±20%	0	1	1	1	0	0	1	1	1	0	0	0	1848
+10 mV	-0.09 V ±20%	0	1	1	1	1	1	1	0	1	1	0	0	2028
0 mV	< 20 mV	1	0	0	0	0	0	0	0	0	0	0	0	2048
-10 mV	+0.09 V ±20%	1	0	0	0	0	0	0	1	0	1	0	0	2068
-100 mV	+0.92 V ±20%	1	0	0	0	1	1	0	0	1	0	0	0	2248
-999 mV	+9.22 V ±20%	1	1	1	1	1	1	0	0	1	1	1	0	4046
-1.00 V	+0.92 V ±20%	1	0	0	0	1	1	0	0	1	0	0	0	2248
-5.12 V	+4.70 V ±20%	1	1	0	0	0	0	0	0	0	0	0	0	3072
-7.95 V	+7.35 V ±20%	1	1	1	0	0	0	1	1	0	1	1	0	3638

Note



If the output levels are set using the HIL and LOL parameters, the microprocessor calculates the appropriate AMP and OFS parameters to use with the hardware. Q0 is only used when (HIL - LOL) is an odd number, since $OFS = (HIL - LOL)/2$ and the offset then needs a 0.5 mV correction.

3. Check that U17 operates according to the following table:

Table 10.5-10. U17 Offset Range Selection

Offset Range	Pin 10 OFFS	ON channel
		Pin 15 to:
0 mV ± 999 mV	H	Pin 1
± 1.00 V ± 7.95 V	L	Pin 2

Capacitance Amplifier

Check U3 and its associated relays against the following table:

Table 10.5-11. U3 Capacitance Amplifier Range Selection

Frequency Range	U3 Pin				Relay on
	6	5	4	3	
1.00 mHz - 9.99 mHz	L	H	H	H	K4
10.0 mHz - 99.9 mHz	H	L	H	H	K3
100 mHz - 999 mHz	H	H	L	H	K2
1.00 Hz - 9.99 Hz	H	H	H	L	K1
≥ 10 Hz	H	H	H	H	None

R2 BD PY CONTROL

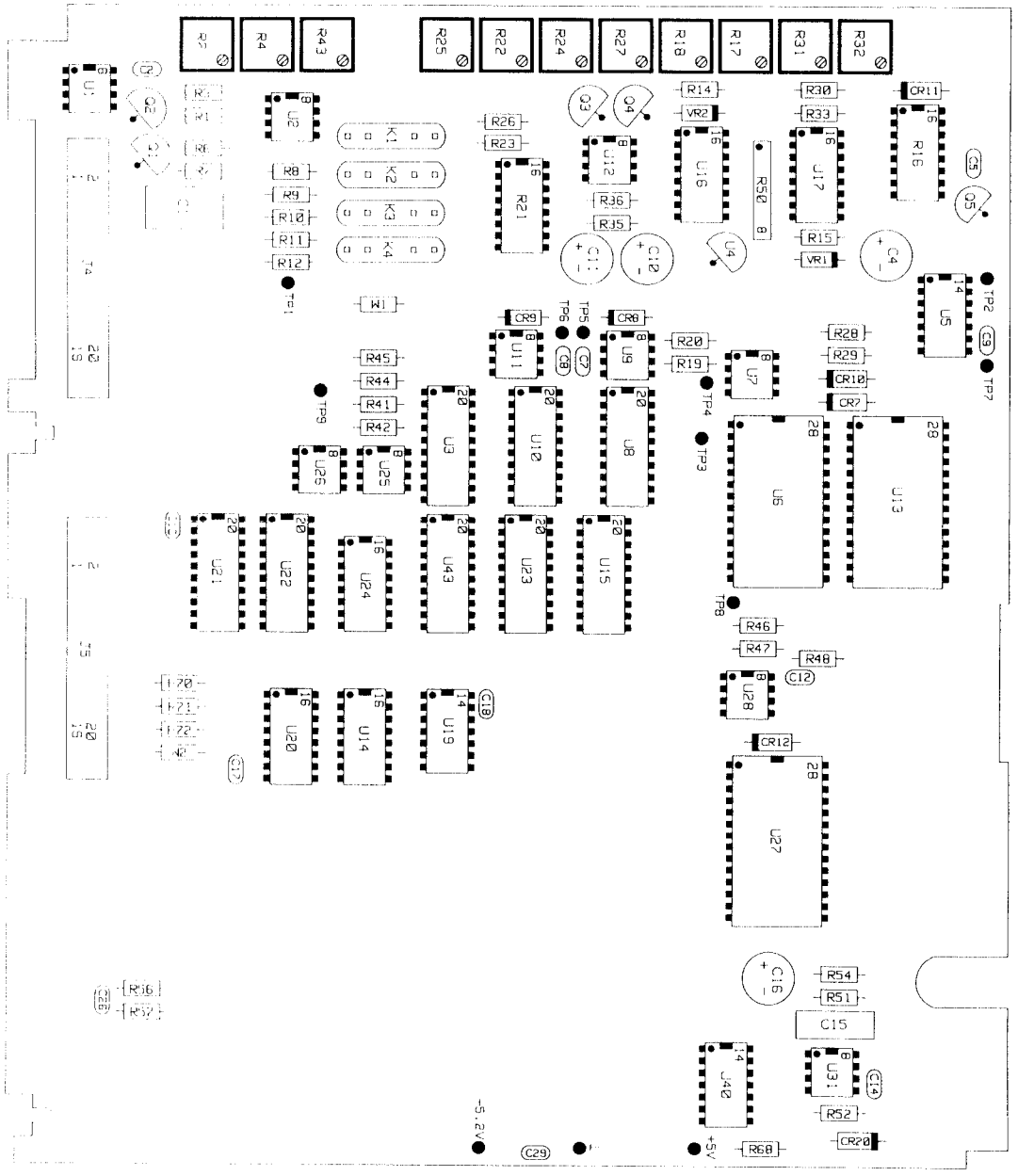

MODEL HP8116R

REF. DES. LOC.	GRID LOC.	REF. DES. LOC.	GRID LOC.
C1	R3	R35	R2
C2	R1	R41	B2
C3	R1	R42	B2
C4	B2	R43	R3
C5	B2	R44	B2
C6	R1	R45	B2
C7	R1	R46	B1
C8	R2	R47	B1
C9	R2	R48	B1
C10	R1	R50	R1
C11	C1	R51	C1
C12	C1	R52	C1
C13	C3	R53	C3
C14	B3	R54	C1
C15	R2	R55	C1
C16	R2	R56	C1
C17	R2	R57	C3
C18	B3	R58	C1
C19	B3	R59	C1
C20	B3	R60	B3
C21	B3	R61	B3
C22	B3	R62	B3
C23	B3	R63	B3
C24	B3	R64	B3
C25	B3	R65	B3
C26	B3	R66	B3
C27	B3	R67	B3
C28	B3	R68	B3
C29	B3	R69	B3
C30	B3	R70	B3
C31	B3	R71	B3
C32	B3	R72	B3
C33	B3	R73	B3
C34	B3	R74	B3
C35	B3	R75	B3
C36	B3	R76	B3
C37	B3	R77	B3
C38	B3	R78	B3
C39	B3	R79	B3
C40	B3	R80	B3
C41	B3	R81	B3
C42	B3	R82	B3
C43	B3	R83	B3
C44	B3	R84	B3
C45	B3	R85	B3
C46	B3	R86	B3
C47	B3	R87	B3
C48	B3	R88	B3
C49	B3	R89	B3
C50	B3	R90	B3
C51	B3	R91	B3
C52	B3	R92	B3
C53	B3	R93	B3
C54	B3	R94	B3
C55	B3	R95	B3
C56	B3	R96	B3
C57	B3	R97	B3
C58	B3	R98	B3
C59	B3	R99	B3
C60	B3	R100	B3

FIGURE 10.5-8. STANDARD CONTROL _AYOUT AND LOCATOR
SERVICING THE STANDARD CONTROL BOARD 10.5-17

10.6

Servicing the Option 001 Control Board

Theory of Operation

Introduction This chapter covers the extra circuitry implemented on the Option 001 control-board to provide the burst modes and sweep modes. Refer to Chapter 10.5 for the standard control-board functions as these remain the same on the Option 001 board. Note that the majority of the optional hardware relates to burst-generation because frequency-sweeping is software controlled.

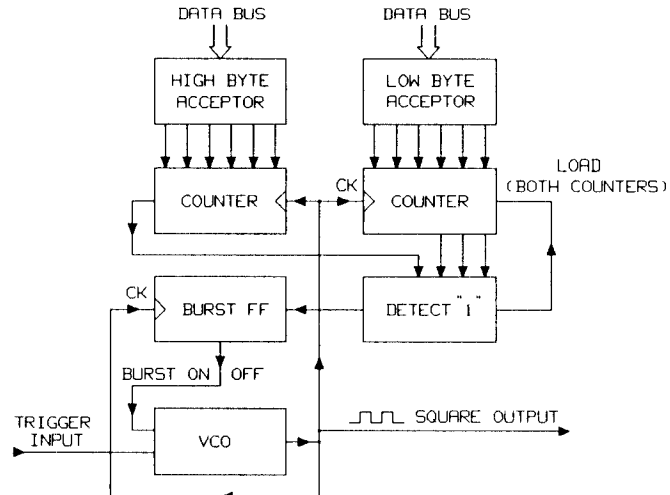

Figure 10.6-1. Simplified Burst Generator (Option 001)

Figure 10.6-1 shows a simplified view of the burst-generator circuits. The burst flip-flop and the VCO are located on the main board, not on the control board. Refer to Figure 10.6-3 and Figure 10.6-4.

Burst Number Acceptors

The burst number is loaded into latches U18 and U15 on receipt of $\overline{\text{LBB}}$ (low byte burst) and $\overline{\text{HBB}}$ (high byte burst) from the control-board address decoder. The $\overline{\text{LBC}}$ signal loads the burst number into the counter circuits and resets the blocking flip-flop U35 which allows the counter to start counting down.

Counter The 11-bit counter consists of two 4-bit counter ICs (U41 and U42) and three flip-flops U35 and U36A which handle the three least-significant bits. The whole counter counts down when clocked by the burst-clock signal from the main board. The burst-clock signal is enabled by the burst-on signal which is withdrawn when the counter reaches 1 (See “Blocking Flip-flop”).

Blocking Flip-flop The blocking flip-flop U39 is set by U40B when both counter ICs reach zero. The Q output disables counter U41 and the \bar{Q} output enables the wired-or “Detect 1” circuit. The count-down continues until the counter flip-flops (U35 and U36A) reach 1 and the burst-on signal is withdrawn, stopping the burst-clock signal.

X-Output Generator DAC U29 is used to produce a frequency-related output-voltage during frequency sweeps. The software arranges that 0 V corresponds to the starting frequency (STA) and the voltage increases by 1.5 V for each frequency decade swept as shown in Figure 10.6-2.

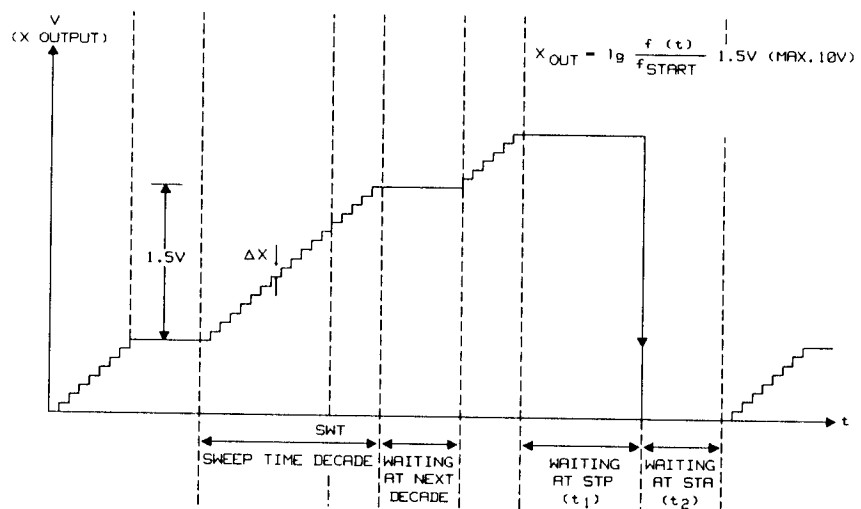

Figure 10.6-2. X-output in sweep mode

Marker Output The marker output is driven by the microprocessor using a spare bit in the offset data latch U23. The output is TTL compatible.

Hold Input The hold input is connected to the enable input on latch U3. If the input is held high (TTL) the latch is disabled, its outputs become high-impedance and the capacitance-amplifier feedback path is removed. The overall effect is that for frequencies < 10 Hz the VCO timing capacitor is isolated and the HP 8116A's output sweep stops with the output voltage held at its current level. The sweep continues when the hold input is switched low.

P/O A2 CONTROL BOARD (OPT. 001)

1

2

3

4

BURST NUMBER ACCEPTOR'S

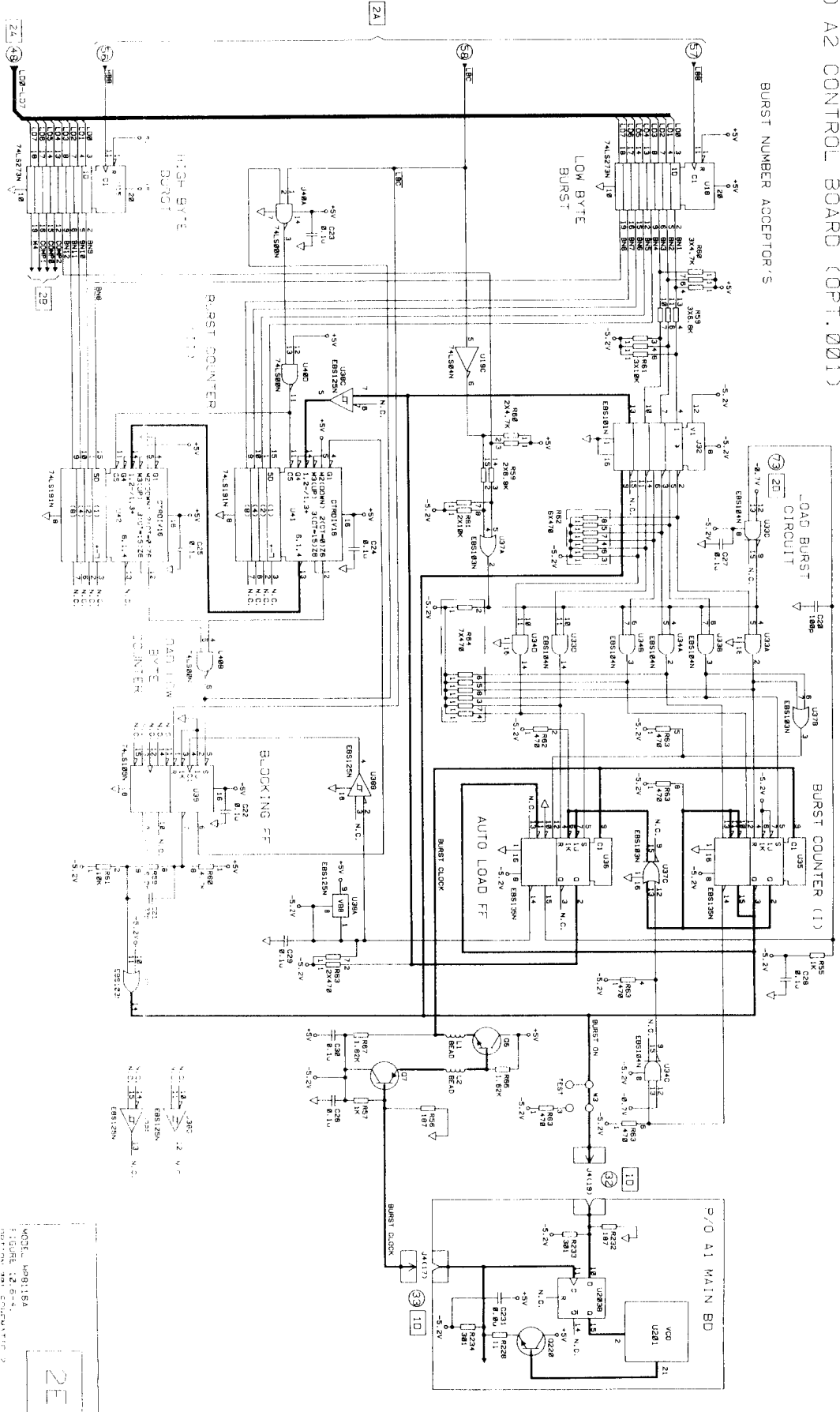

2E

MODEL 988115A
 FIGURE 12.6-4
 PARTITION 201 SCHEMATIC ?
 SERVICING THE OPTION 001 CONTROL BOARD 12.6-5

Troubleshooting

Note



- If an error code is being displayed by the HP 8116A you must press a key, **LCL** for example, to return the microprocessor to normal operation before troubleshooting.
- The component layout and locator for the Option 001 control board A2 is at the end of the chapter.

Output Address Decoder

Address decoder U20 provides control signals for the Option 001 circuits. These can be checked using signature analysis, refer to "Address Decoders" in Chapter 10.5.

Burst Counter

Test the burst counter circuits using the following procedure:

1. Switch off the HP 8116A
2. Desolder wire W3 on the control board A2 and resolder it to the "test" position.
3. Connect A1 U203 pin 10 to ground.
4. Switch on the HP 8116A and set it up as follows:

Control	E.BUR
BUR	1024
FRQ	1 MHz
5. Press the **MAN** button
6. Check the TTL logic levels at the outputs of U18 and U15:

Table 10.6-1.

Signal	Pin	Level
BN1	U18 Pin 2	L
BN2	U18 Pin 5	L
BN3	U18 Pin 6	L
BN4	U18 Pin 9	L
BN5	U18 Pin 12	L
BN6	U18 Pin 15	L
BN7	U18 Pin 16	L
BN8	U18 Pin 19	L
BN9	U15 Pin 2	L
BN10	U15 Pin 5	L
BN11	U15 Pin 6	H

7. Using an oscilloscope and ECL- and TTL-logic probes you can test the burst- counter waveform and timing data against Figure 10.6-5.

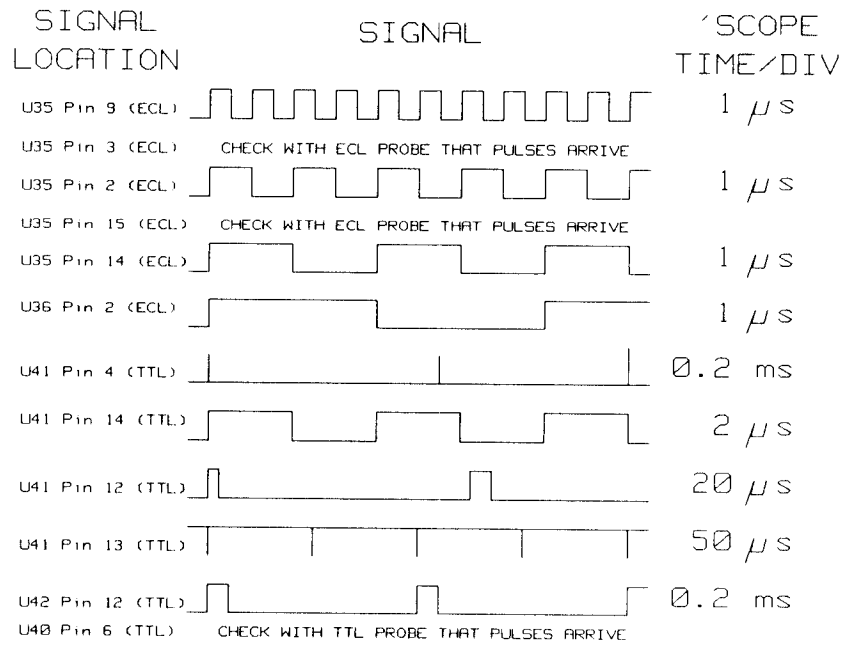
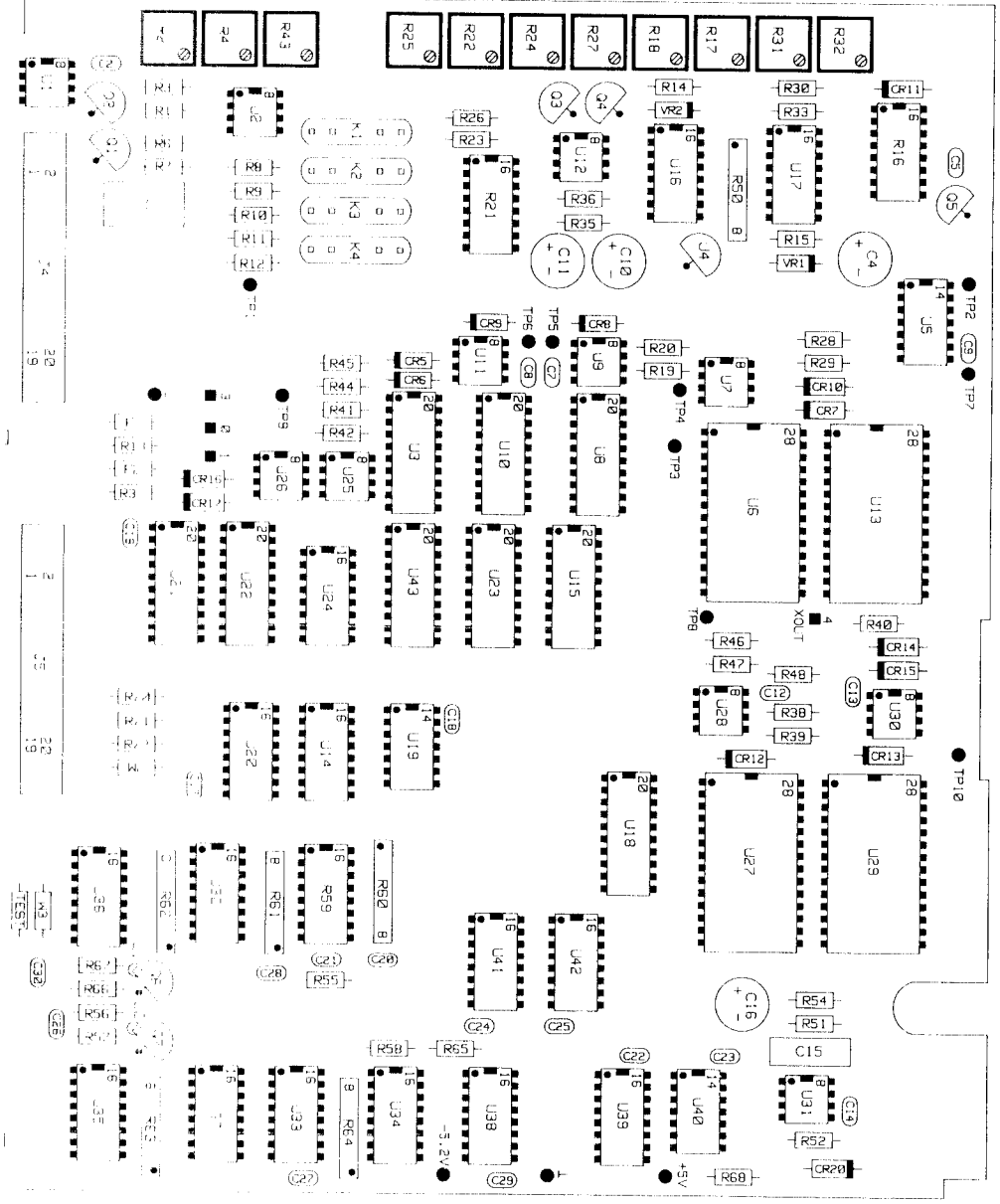

Figure 10.6-5. Burst-counter waveform and timing data

R2 BD HY CONTROL (OPT. 021)

H B C



REF. DES.	GRID REF. LOC.	GRID REF. DES.	GRID REF. LOC.	REF. DES.	GRID REF. LOC.
C1	A3	R7	A3	TP4	B2
C2	A1	R8	A3	TP5	A2
C3	A1	R9	A3	TP6	A2
C4	B1	R10	A3	TP7	A1
C5	B2	R11	A3	TP8	A1
C6	B2	R12	A3	TP9	B1
C7	B2	R13	A3	TP10	B1
C8	A1	R14	A2	U1	A1
C9	A1	R15	A1	U2	A1
C10	A2	R16	A1	U3	A1
C11	B1	R17	A1	U4	A1
C12	B1	R18	A1	U5	A1
C13	B1	R19	A2	U6	B1
C14	C1	R20	A2	U7	B1
C15	C1	R21	A2	U8	B2
C16	C3	R22	A2	U9	B2
C17	C3	R23	A2	U10	B2
C18	B2	R24	A2	U11	B2
C19	B2	R25	A2	U12	B2
C20	C2	R26	A2	U13	B2
C21	C2	R27	A1	U14	B2
C22	C2	R28	A1	U15	B2
C23	C1	R29	A1	U16	B2
C24	C2	R30	A1	U17	B2
C25	C2	R31	A1	U18	B2
C26	C2	R32	A1	U19	B2
C27	C2	R33	A1	U20	B2
C28	C3	R34	A1	U21	B3
C29	C3	R35	A1	U22	B3
C30	C3	R36	A1	U23	B3
C31	C3	R37	A1	U24	B3
C32	C3	R38	A1	U25	B3
C33	C3	R39	A1	U26	B3
C34	C3	R40	A1	U27	B3
C35	C3	R41	A1	U28	B3
C36	C3	R42	A1	U29	B3
C37	C3	R43	A1	U30	B3
C38	C3	R44	A1	U31	B3
C39	C3	R45	A1	U32	B3
C40	C3	R46	A1	U33	B3
C41	C3	R47	A1	U34	B3
C42	C3	R48	A1	U35	B3
C43	C3	R49	A1	U36	B3
C44	C3	R50	A1	U37	B3
C45	C3	R51	A1	U38	B3
C46	C3	R52	A1	U39	B3
C47	C3	R53	A1	U40	B3
C48	C3	R54	A1	U41	B3
C49	C3	R55	A1	U42	B3
C50	C3	R56	A1	U43	B3
C51	C3	R57	A1	U44	B3
C52	C3	R58	A1	U45	B3
C53	C3	R59	A1	U46	B3
C54	C3	R60	A1	U47	B3
C55	C3	R61	A1	U48	B3
C56	C3	R62	A1	U49	B3
C57	C3	R63	A1	U50	B3
C58	C3	R64	A1	U51	B3
C59	C3	R65	A1	U52	B3
C60	C3	R66	A1	U53	B3
C61	C3	R67	A1	U54	B3
C62	C3	R68	A1	U55	B3
C63	C3	R69	A1	U56	B3
C64	C3	R70	A1	U57	B3
C65	C3	R71	A1	U58	B3
C66	C3	R72	A1	U59	B3
C67	C3	R73	A1	U60	B3
C68	C3	R74	A1	U61	B3
C69	C3	R75	A1	U62	B3
C70	C3	R76	A1	U63	B3
C71	C3	R77	A1	U64	B3
C72	C3	R78	A1	U65	B3
C73	C3	R79	A1	U66	B3
C74	C3	R80	A1	U67	B3
C75	C3	R81	A1	U68	B3
C76	C3	R82	A1	U69	B3
C77	C3	R83	A1	U70	B3
C78	C3	R84	A1	U71	B3
C79	C3	R85	A1	U72	B3
C80	C3	R86	A1	U73	B3
C81	C3	R87	A1	U74	B3
C82	C3	R88	A1	U75	B3
C83	C3	R89	A1	U76	B3
C84	C3	R90	A1	U77	B3
C85	C3	R91	A1	U78	B3
C86	C3	R92	A1	U79	B3
C87	C3	R93	A1	U80	B3
C88	C3	R94	A1	U81	B3
C89	C3	R95	A1	U82	B3
C90	C3	R96	A1	U83	B3
C91	C3	R97	A1	U84	B3
C92	C3	R98	A1	U85	B3
C93	C3	R99	A1	U86	B3
C94	C3	R100	A1	U87	B3
C95	C3	R101	A1	U88	B3
C96	C3	R102	A1	U89	B3
C97	C3	R103	A1	U90	B3
C98	C3	R104	A1	U91	B3
C99	C3	R105	A1	U92	B3
C100	C3	R106	A1	U93	B3
C101	C3	R107	A1	U94	B3
C102	C3	R108	A1	U95	B3
C103	C3	R109	A1	U96	B3
C104	C3	R110	A1	U97	B3
C105	C3	R111	A1	U98	B3
C106	C3	R112	A1	U99	B3
C107	C3	R113	A1	U100	B3
C108	C3	R114	A1	U101	B3
C109	C3	R115	A1	U102	B3
C110	C3	R116	A1	U103	B3
C111	C3	R117	A1	U104	B3
C112	C3	R118	A1	U105	B3
C113	C3	R119	A1	U106	B3
C114	C3	R120	A1	U107	B3
C115	C3	R121	A1	U108	B3
C116	C3	R122	A1	U109	B3
C117	C3	R123	A1	U110	B3
C118	C3	R124	A1	U111	B3
C119	C3	R125	A1	U112	B3
C120	C3	R126	A1	U113	B3
C121	C3	R127	A1	U114	B3
C122	C3	R128	A1	U115	B3
C123	C3	R129	A1	U116	B3
C124	C3	R130	A1	U117	B3
C125	C3	R131	A1	U118	B3
C126	C3	R132	A1	U119	B3
C127	C3	R133	A1	U120	B3
C128	C3	R134	A1	U121	B3
C129	C3	R135	A1	U122	B3
C130	C3	R136	A1	U123	B3
C131	C3	R137	A1	U124	B3
C132	C3	R138	A1	U125	B3
C133	C3	R139	A1	U126	B3
C134	C3	R140	A1	U127	B3
C135	C3	R141	A1	U128	B3
C136	C3	R142	A1	U129	B3
C137	C3	R143	A1	U130	B3
C138	C3	R144	A1	U131	B3
C139	C3	R145	A1	U132	B3
C140	C3	R146	A1	U133	B3
C141	C3	R147	A1	U134	B3
C142	C3	R148	A1	U135	B3
C143	C3	R149	A1	U136	B3
C144	C3	R150	A1	U137	B3
C145	C3	R151	A1	U138	B3
C146	C3	R152	A1	U139	B3
C147	C3	R153	A1	U140	B3
C148	C3	R154	A1	U141	B3
C149	C3	R155	A1	U142	B3
C150	C3	R156	A1	U143	B3
C151	C3	R157	A1	U144	B3
C152	C3	R158	A1	U145	B3
C153	C3	R159	A1	U146	B3
C154	C3	R160	A1	U147	B3
C155	C3	R161	A1	U148	B3
C156	C3	R162	A1	U149	B3
C157	C3	R163	A1	U150	B3
C158	C3	R164	A1	U151	B3
C159	C3	R165	A1	U152	B3
C160	C3	R166	A1	U153	B3
C161	C3	R167	A1	U154	B3
C162	C3	R168	A1	U155	B3
C163	C3	R169	A1	U156	B3
C164	C3	R170	A1	U157	B3
C165	C3	R171	A1	U158	B3
C166	C3	R172	A1	U159	B3
C167	C3	R173	A1	U160	B3
C168	C3	R174	A1	U161	B3
C169	C3	R175	A1	U162	B3
C170	C3	R176	A1	U163	B3
C171	C3	R177	A1	U164	B3
C172	C3	R178	A1	U165	B3
C173	C3	R179	A1	U166	B3
C174	C3	R180	A1	U167	B3
C175	C3	R181	A1	U168	B3
C176	C3	R182	A1	U169	B3
C177	C3	R183	A1	U170	B3
C178	C3	R184	A1	U171	B3
C179	C3	R185	A1	U172	B3
C180	C3	R186	A1	U173	B3
C181	C3	R187	A1	U174	B3
C182	C3	R188	A1	U175	B3
C183	C3	R189	A1	U176	B3
C184	C3	R190	A1	U177	B3
C185	C3	R191	A1	U178	B3
C186	C3	R192	A1	U179	B3
C187	C3	R193	A1	U180	B3
C188	C3	R194	A1	U181	B3
C189	C3	R195	A1	U182	B3
C190	C3	R196	A1	U183	B3
C191	C3	R197	A1	U184	B3
C192	C3	R198	A1	U185	B3
C193	C3	R199	A1	U186	B3
C194	C3	R200	A1	U187	B3
C195	C3	R201	A1	U188	B3
C196	C3	R202	A1	U189	B3
C197	C3	R203	A1	U190	B3
C198	C3	R204	A1	U191	B3
C199	C3	R205	A1	U192	B3
C200	C3	R206	A1	U193	B3
C201	C3	R207	A1	U194	B3
C202	C3	R208	A1	U195	B3
C203	C3	R209	A1	U196	B3
C204	C3	R210	A1	U197	B3
C205	C3	R211	A1	U198	B3
C206	C3	R212	A1	U199	B3
C207	C3	R213	A1	U200	B3
C208	C3	R214	A1	U201	B3
C209	C3	R215	A1	U202	B3
C210	C3	R216	A1	U203	B3
C211	C3	R217	A1	U204	B3
C212	C3	R218	A1	U205	B3
C213	C3	R219	A1	U206	B3
C214	C3	R220	A1	U207	B3
C215	C3	R221	A1	U208	B3
C216	C3	R222	A1	U209	B3
C217	C3	R223	A1	U210	B3
C218	C3	R224	A1	U211	B3
C219	C3	R225	A1	U212	B3
C220	C3	R226	A1	U213	B3
C221	C3	R227	A1	U214	B3
C222	C3	R228	A1	U215	B3
C223	C3	R229	A1	U216	B3
C224	C3	R230	A1	U217	B3
C225	C3	R231	A1	U218	B3
C226	C3	R232	A1	U219	B3
C227	C3	R233	A1	U220	B3
C228	C3	R234	A1	U221	B3
C229	C3	R235	A1	U222	B3
C230	C3	R236	A1	U223	B3
C231	C3	R237	A1	U224	B3
C232	C3	R238	A1	U225	B3
C233	C3	R239	A1	U226	B3
C234	C3	R240	A1	U227	B3
C235	C3	R241	A1	U228	B3
C236	C3	R242	A1	U229	B3
C237	C3	R243	A1	U230	B3
C238	C3	R244	A1	U231	B3
C239	C3	R245	A1	U232	B3
C240	C3	R246	A1	U233	B3
C241	C3	R247	A1	U234	B3
C242	C3	R248	A1	U235	B3
C243	C3	R249	A1	U236	B3
C244	C3	R250	A1	U237	B3
C245	C3	R251	A1	U238	B3
C246	C3	R252	A1	U239	B3
C247	C3	R253	A1	U240	B3
C248	C3	R254	A1	U241	B3
C249	C3	R255	A1	U242	B3
C250	C3	R256	A1	U243	B3
C251	C3	R257	A1	U244	B3
C252	C3	R258	A1	U245	B3
C253	C3	R259	A1	U246	B3
C254	C3	R260	A1	U247	B3
C255	C3	R261	A1	U248	B3
C256	C3	R262	A1	U249	B3
C					

10.7

Servicing the Microprocessor and Frontpanel

Theory of Operation

Introduction The microprocessor board is the control center of the HP 8116A. The microprocessor monitors the keyboard and HP-IB, interprets the key-presses and commands, and implements them by sending control data to the control circuits and updating the front-panel display and LEDs.

When in remote control mode all the front panel keys, except **LCL**, are ignored by the microprocessor. If the local lockout command has been received on the HP-IB then the **LCL** key is also ignored.

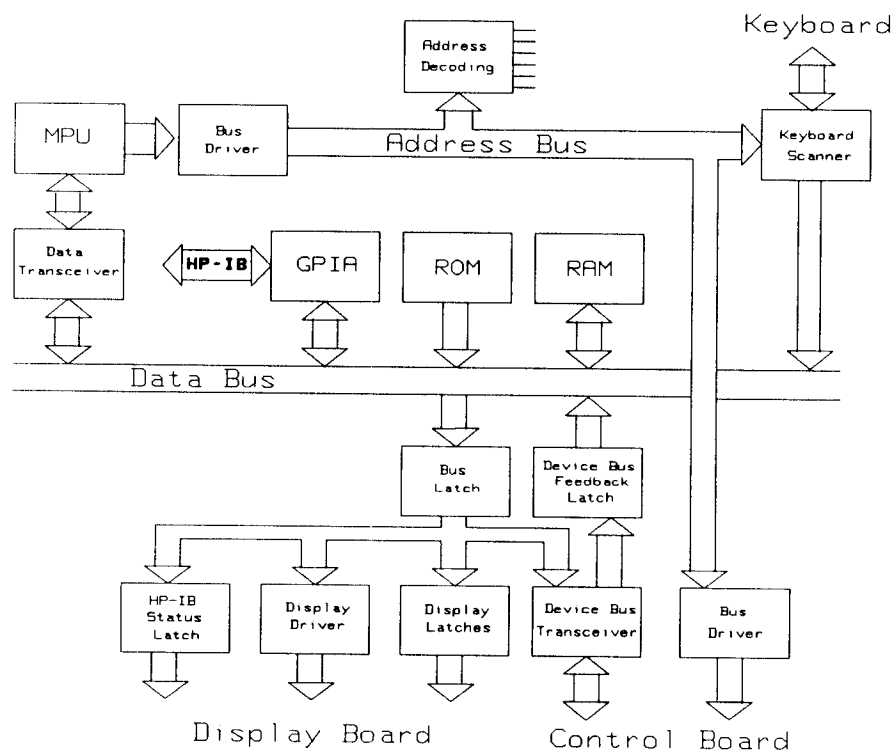

Figure 10.7-1. Microprocessor board architecture

Figure 10.7-1 summarises the parts of the microprocessor board and the connecting busses. The purpose of the address bus is to allow the microprocessor to select a particular location in the instrument. The location can be in ROM, in RAM, in the GPIA, or one of the other devices. The data bus allows the microprocessor to read data from,

or write data to, the addressed location. Note that some devices can only be read from, others can only be written to, and others can both be read from and written to.

Read Only Memory (ROM)

The ROM is a permanent data-store which contains the microprocessor program and other fixed data such as the standard parameter set.

Random Access Memory (RAM)

The RAM is a data-store which the microprocessor can write to and read from using the read/write (R/\overline{W}) control line to choose which operation is required.

The RAM is used to store the current parameter set and temporary data needed by the microprocessor. The HP 8116A's RAM has a battery back-up power supply, described in the following section, which means the data in the RAM is maintained while the instrument is switched off. This allows the current parameter set to be restored when the instrument is switched on again.

The normally negative "Power Down Detected" signal is used to ensure that the RAM data is not corrupted when the instrument is switched off. (Refer to Figure 10.7-5). Normally U27A's output is low, U27B's output is therefore positive and the RAM SELECT output from U15C can enable the RAM by switching on U29C. When the "Power Down Detect" signal goes high, U27A's output goes low, U27B's output goes low and U15C cannot switch on U29C. Therefore the RAM becomes, or remains, disabled.

RAM Battery Supply

When the instrument is operating, U27C's output is high, Q1 is switched on and the RAM U10 is powered from the +5 V supply. (Refer to Figure 10.7-5). When the "Power Down Detected" signal goes high, U27C's output goes low and switches off Q1. The +5V supply to the RAM is now maintained by the battery BT1.

HP-IB General Purpose Interface Adapter

The GPIA IC U30 interfaces between the microprocessor and the HP-IB, as shown in Figure 10.7-4. The IC pin configuration is given in Figure 10.7-2.

Microprocessor Interface Signals

D0-D7. Eight bidirectional, tri-state data lines allowing data transfer between the microprocessor and the GPIA.

\overline{CS} . A negative edge selects the GPIA enabling the microprocessor to communicate with the GPIA.

R/\overline{W} . The $READ/\overline{WRITE}$ input controls GPIA register access and the direction of data transfer on the data pins. It is connected to the microprocessor's $READ/\overline{WRITE}$ output.

RS0-RS2. The register select lines are connected to the three lowest address lines A0-A2 and allow the microprocessor to choose a GPIA register to read from or write to.

IRQ. The interrupt request output allows the GPIA to interrupt the microprocessor.

RESET. This input is used to initialize the GPIA. The signal is the same $\overline{\text{RESET}}$ signal generated to reset the microprocessor.

E. The enable input activates the address inputs, $\text{R}/\overline{\text{W}}$ input and enables data transfer with the data bus. It is also used internally as a state counter, allowing the GPIA to change interface states. E is connected to the microprocessor's clock output.

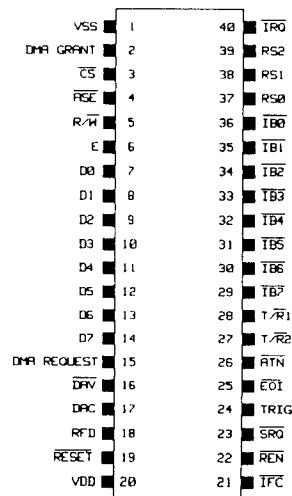

Figure 10.7-2. GPIA IC pins

HP-IB Interface Signals

IB0-IB7. Eight HP-IB data lines.

DAC. When valid data is received, the GPIA switches DAC high to indicate that the data has been accepted.

RFD. The GPIA switches the RFD line high to indicate that it is ready for data.

$\overline{\text{DAV}}$. The GPIA pulls the $\overline{\text{DAV}}$ line low to indicate that it has valid data to transmit.

$\overline{\text{ATN}}$, IFC, SRQ, EOI, REN. These bus management lines are used to control the flow of data on the HP-IB data lines.

Address Decoding

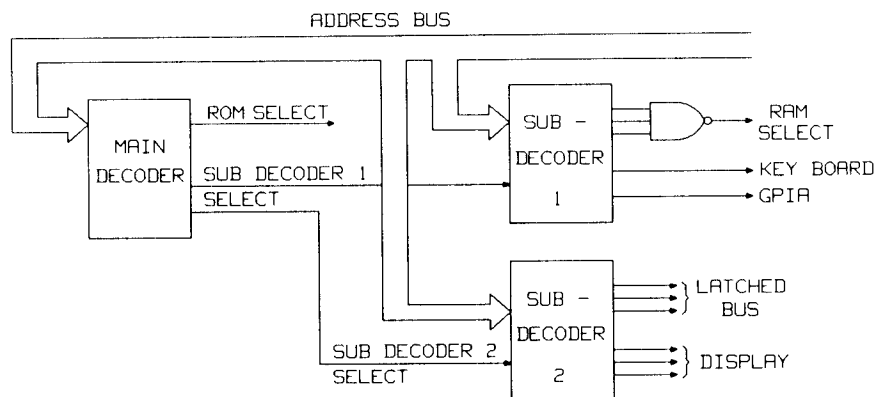

Figure 10.7-3. Address decoding

Address decoding is performed at two levels, as shown in Figure 10.7-3. The main decoder U12 uses microprocessor address lines A12, A13 and A15 to enable one of the following:

- ROM U40
- Sub-decoder 1 U13
- Sub-decoder 2 U14

Sub-decoder 1

If sub-decoder 1 U13 is enabled by the main decoder, it uses microprocessor address lines A8, A9 and A10 to enable one of the following:

- RAM U10
- Keyboard Scanner U19
- GPIA U30

Sub-decoder 2

If sub-decoder 2 U14 is enabled by the main decoder, it uses microprocessor address lines A0, A1 and A2 to enable one of the following:

- Latched Data Bus Latch U16
- Control Board Addressing via U17,U18,U21 (Refer to “Control Board Address Decoding”)
- Device Bus Feedback Latch U26
- Display Latches U23, U24
- HP-IB Status Latch U37

Control Board Address Decoding

Address decoding for the control board functions is partially carried out on the microprocessor board. Address lines A3–A9 and A14 are passed through latch U18 under the control of sub-decoder 2 (U14). A14 then becomes the $\overline{\text{MODE}}$ control for the display driver (refer to “Display Driving”), while A3–A9 pass through bus driver U21. Decoder U17 uses A6 and A7 to produce the “write select” signals $\overline{\text{WS1}}\text{--}\overline{\text{WS6}}$ and the $\overline{\text{WRITE}}$ signal to the display driver (refer to “Display Driving”).

Key Scanning

Refer to Figure 10.7-6 and Figure 10.7-7 (Figure 10.7-8 for Option 001). The keyboard assembly A4 is a switch panel on which all mode, control, parameter, waveform, output and trigger control pushbuttons are mounted. The microprocessor scans the frontpanel key matrix using a BCD to decimal converter U20 and an 8-to-1 multiplexer U19. A3, A4 and A5 are the inputs to U20 and are continuously incremented from one to six by the microprocessor. The six “decimal” outputs from U20, KD0–KD5, are used as the vertical signal paths to the key matrix. The horizontal signal paths of the key matrix, KS0–KS7, form the inputs to the multiplexer U19, which is controlled by address lines A0, A1 and A2. The output from U19 therefore represents the state of the key joining the vertical signal path (addressed by A3–A5) and the horizontal signal path (addressed by A0–A2). Each time the microprocessor increments the address to U20 it cycles the address to U19 through all 8 horizontal paths.

Display Driving

Display Driver U22

The display driver operates the key, mode, control and unit LEDs, along with the individual digital display segments, using a matrix technique similar to the keyboard. The outputs DIG0–DIG7 form the vertical signal paths while the outputs a–g and DP form the horizontal paths. The display driver contains 8 bytes of RAM which store 8 data bits (a–g and DP) to be used with each of the 8 “digit” outputs DIG0–DIG7.

The $\overline{\text{MODE}}$ signal determines whether the display driver interprets data as control instructions or display data to be stored in RAM:

Table 10.7-1. Display Driver Control Signals

Signal	Pin	Status	Function
MODE	9	HIGH	Load control instruction on $\overline{\text{WRITE}}$ pulse
		LOW	Load display data on $\overline{\text{WRITE}}$ pulse
$\overline{\text{WRITE}}$	8	HIGH	Data not loaded
		LOW	Data loaded

After the appropriate control instruction, eight bytes of display data are loaded by the microprocessor using eight successive $\overline{\text{WRITE}}$ pulses.

HP-IB Status Latch U37

The data stored in the HP-IB status latch drives the HP-IB status LEDs on the frontpanel.

Display Latches U23,U24

The data stored in the display latches drives the parameter LEDs on the frontpanel.

Reset Circuits

When the instrument is switched on, the microprocessor $\overline{\text{RESET}}$ input is held low (reset) for approximately 2.5 ms. This allows the power supplies to become established before the microprocessor starts running. This delay is achieved using the CR network R12 (3 x 10K) and C4 (0.1 μF). U27D output goes high when C4 has charged to approximately 420 mV and the $\overline{\text{RESET}}$ signal is withdrawn.

When the instrument is switched off, the "Power Down Detected" signal goes high forcing the output of U27A high. This switches on transistor U29A which discharges C4 and switches the output of U27D low. The $\overline{\text{RESET}}$ signal to the microprocessor and GPIA is therefore established before their power supply is totally withdrawn.

P/O A3 MICROPROCESSOR BOARD

1 2 3 4 SERVICE

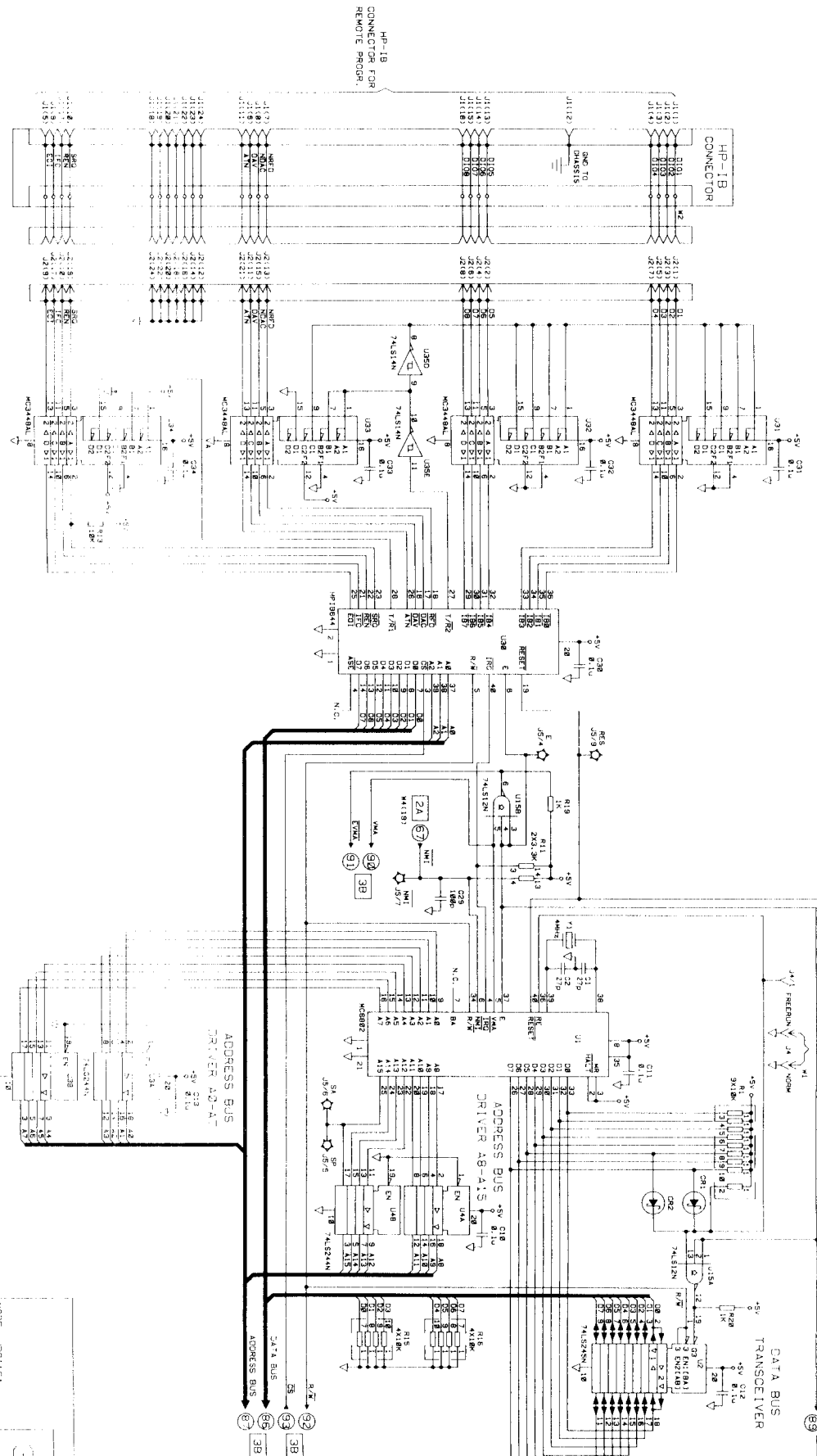

NOTE: REFER TO P/OA3 MICROPROCESSOR BOARD 12.1-4 MICROPROCESSOR AND I/OV SCHEMATIC 12.1-7

P/O A3 MICROPROCESSOR BOARD

1 2 3

SERVICE

FROM A1
MAIN BD

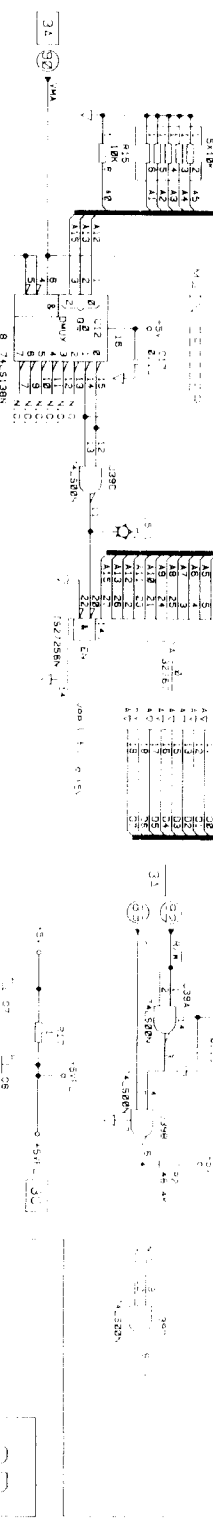
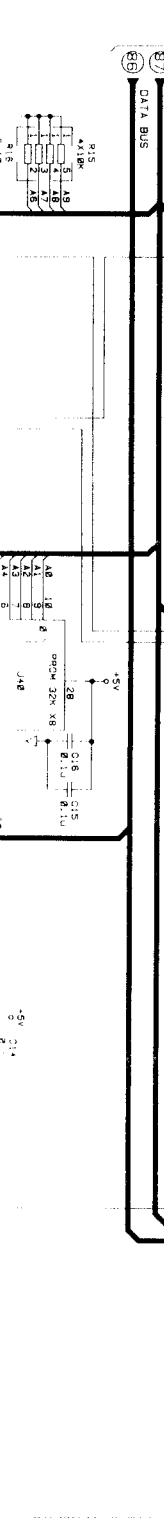
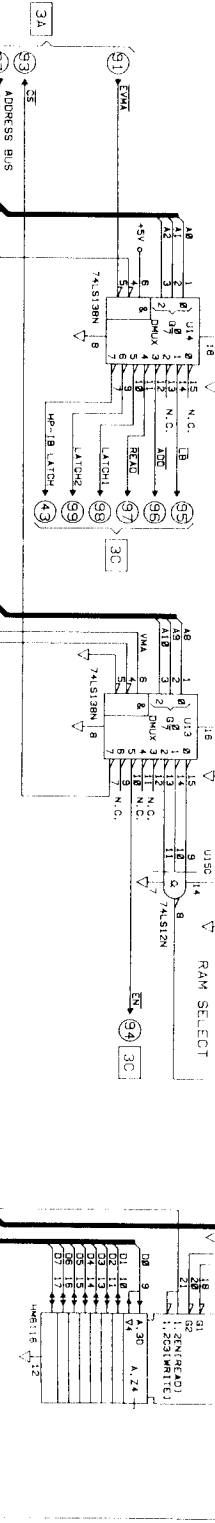
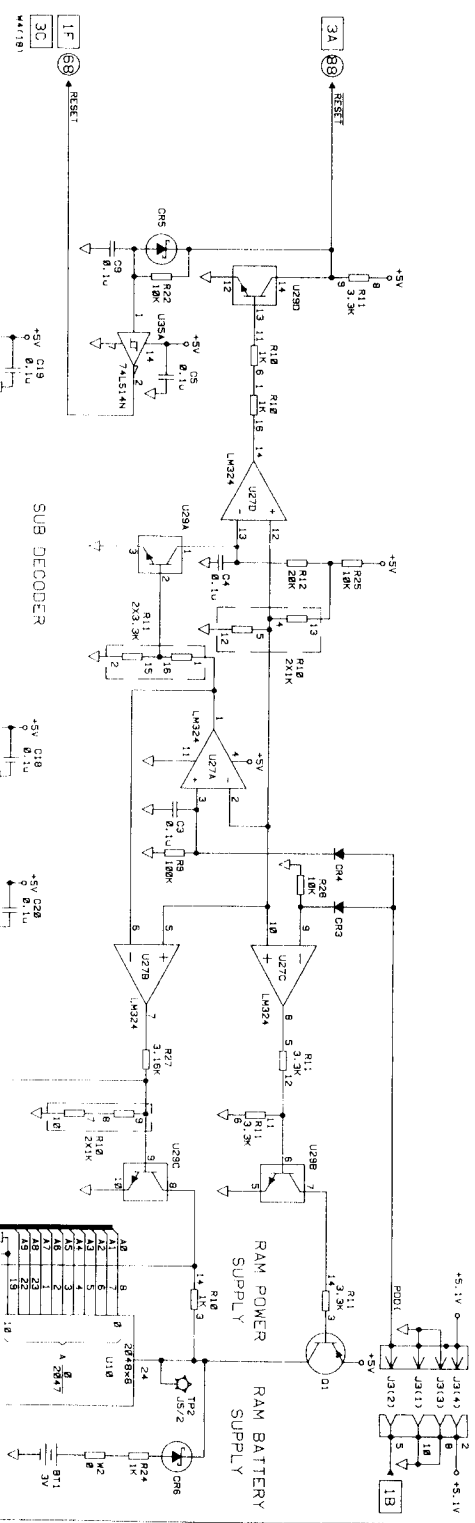
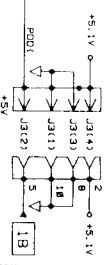

MODE: u09, RA1
L1509: 07-5
MICROPROCESSOR BC A3 SCHEMATIC 2
SERVICING OF MICROPROCESSOR AND MAIN FRAME 1279

P/O A3 MICROPROCESSOR BOARD

3A ADDRESS BUS

DECODER CONTROL

P/O A1 MAIN BOARD

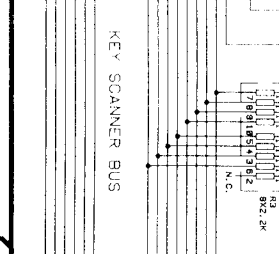
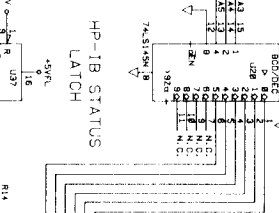
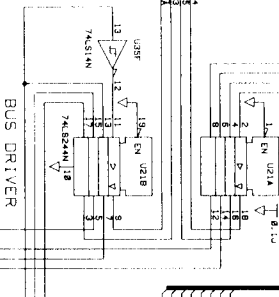

31 DATA BUS

DEVICE BUS FEEDBACK

DEVICE BUS LATCH

DISPLAY LATCH

DISPLAY LATCH

30

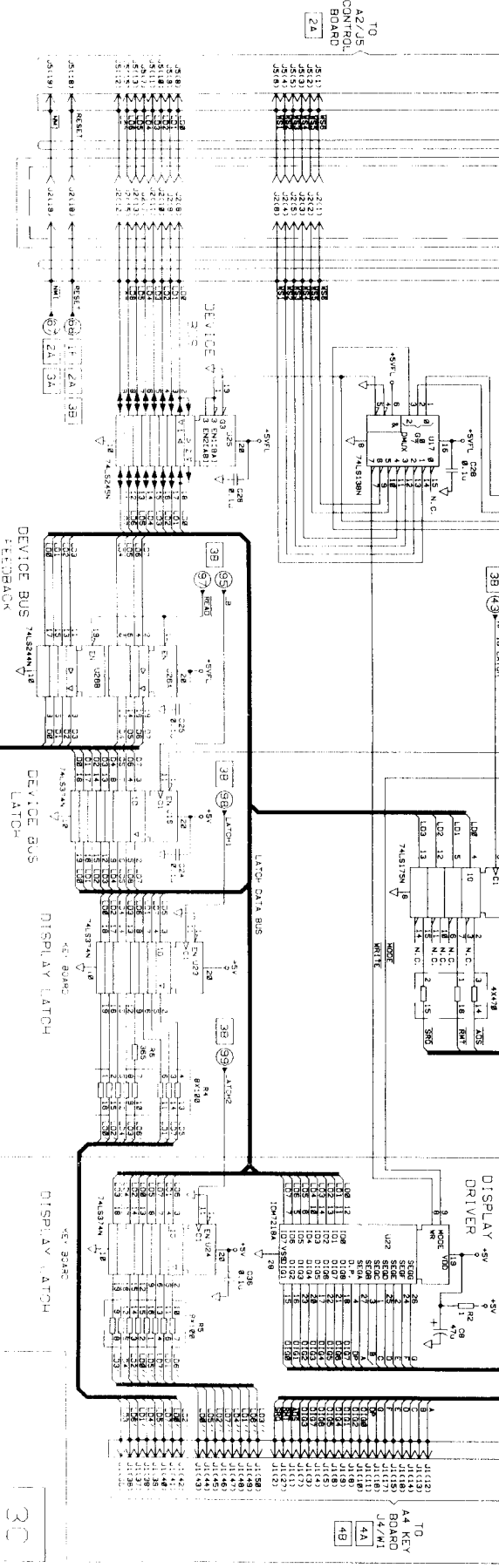

KEY SCANNER BUS
 KEYBOARD BOARD
 MICROPROCESSOR BOARD
 SERVICE PANEL 10.7-11

SERVICE

A4 KEY BOARD

A5 DISPLAY BOARD

SERVICE

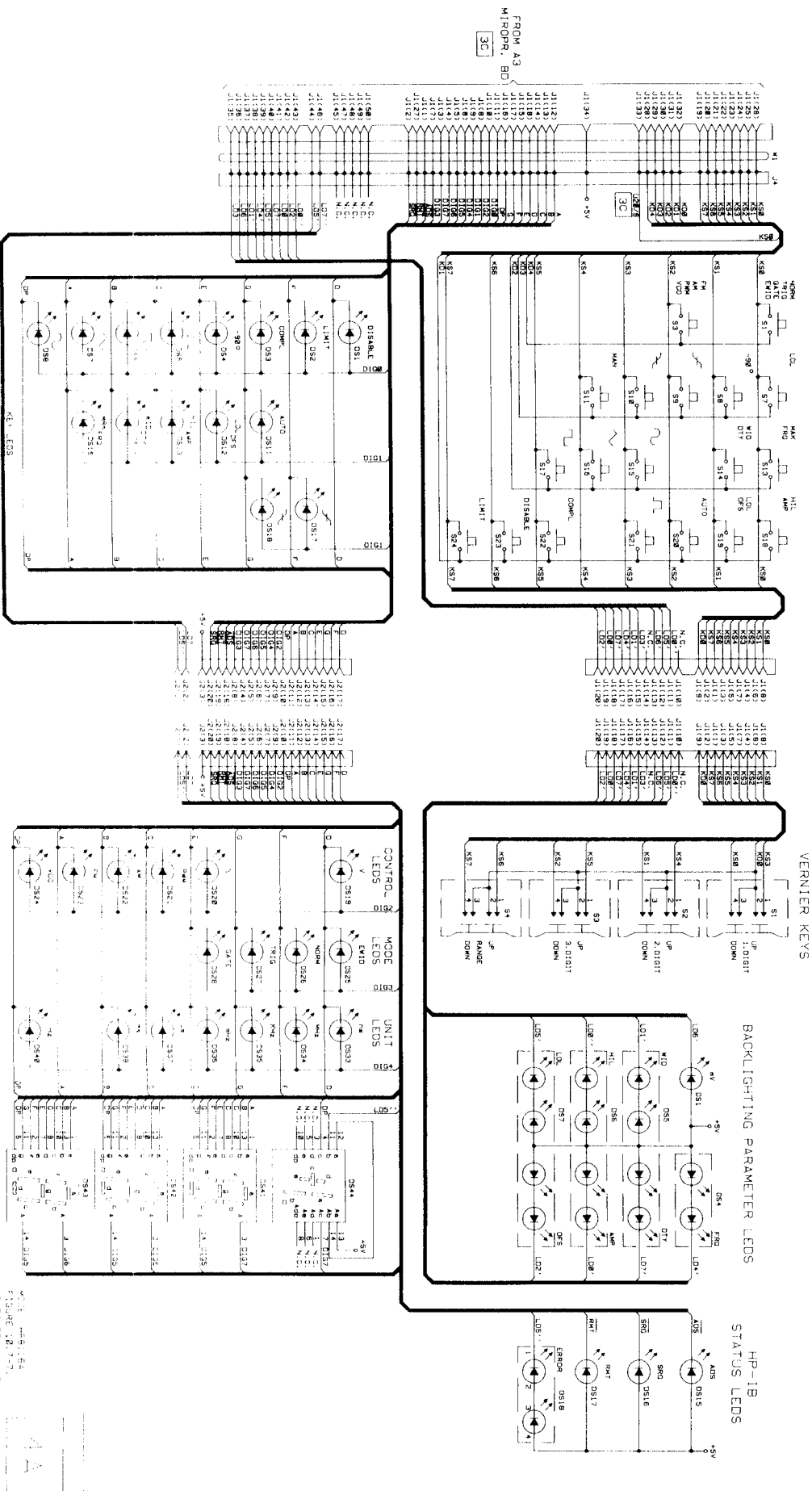

NOTE: SEE SERVICE MANUAL FOR THE LOCATION OF THE MICROPROCESSOR BOARD AND LEAD WIRE MAPS 10-7-13

HP-18
STATUS LEDs

BACKLIGHTING PARAMETER LEDs

VERNIER KEYS

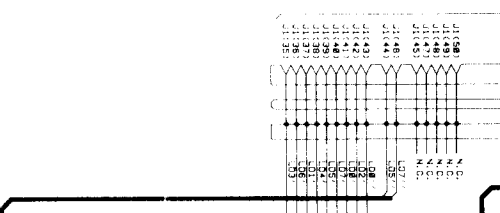
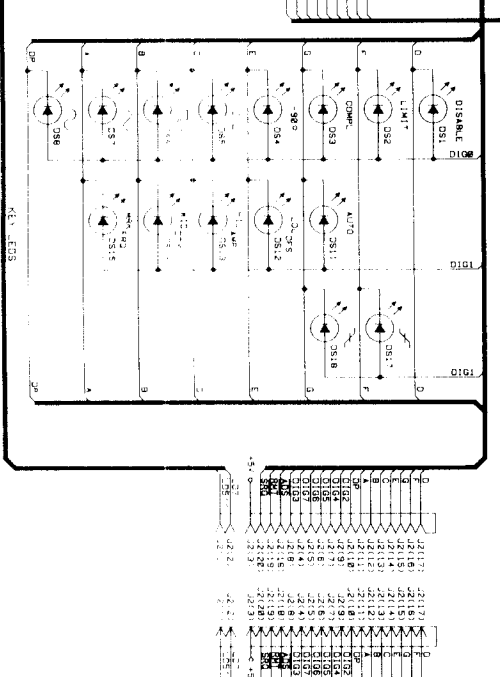
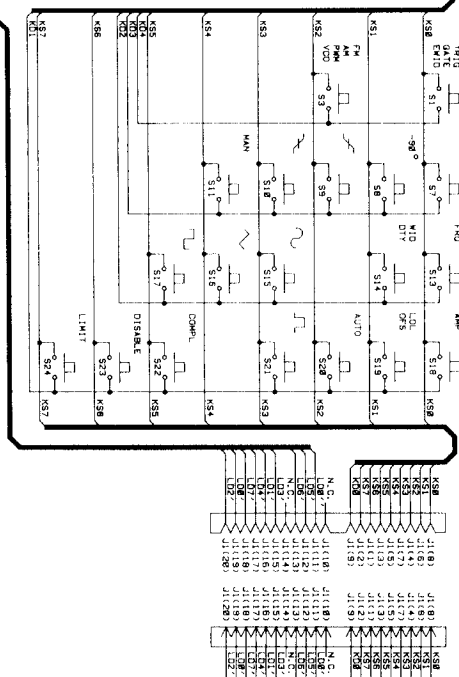
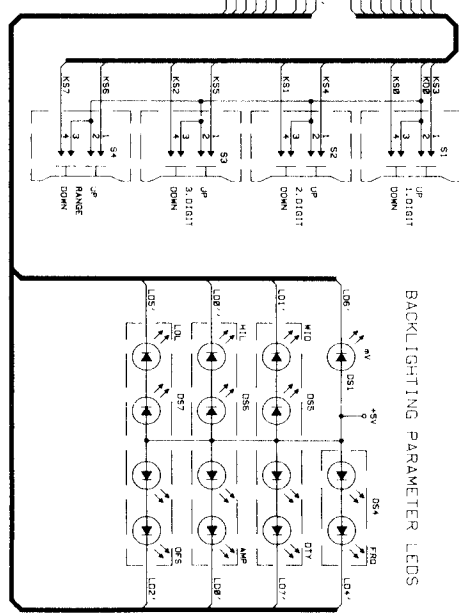

FROM A3
MICROPR. BD
3C

Troubleshooting

Note



- If an error code is being displayed by the HP 8116A you must press a key, (LCL) for example, to return the microprocessor to normal operation before troubleshooting.
- The component layouts and locators for the microprocessor board A3, the keyboard A4 and the display board A5 are at the end of the chapter.

Free Running Signature Analysis

To carry out signature analysis the microprocessor must be set to a free-running routine in which it increments through all addresses continuously. To set the microprocessor to free-run:

1. Move jumper A3P1 to the free-run position
2. Disconnect wire A2W2 to force NMI high
3. Reset the microprocessor by shorting $\overline{\text{RESET}}$ to ground for a short time
4. When you have finished testing, return jumper A3P1 to its normal position and reconnect A2W2.

Address Bus

The address bus drivers and decoders can be checked using signature analysis.

1. Set the microprocessor to free-run as described in “Free Running Signature Analysis” and connect the signature analyzer probes as given in Table 10.7-2.

Table 10.7-2. Signature Analyzer Probe connections

Probe	Trigger	Connect to
Start	<i>f</i>	TP “SA”
Stop	<i>f</i>	TP “SP”
Clock	λ	TP “E”
Ground		Ground

2. Connect the data probe to the microprocessor’s +5 V supply and check that the signature is 0003. If not, the microprocessor is not free-running.
3. Use the data probe to check the signatures given in Table 10.7-3:

Table 10.7-3. Signatures for Address Drivers and Decoders

Pin	U3	U4	U12	U13	U14	U10	U36	U17	U18	U21
1							667C			
2									P50H	
3	6F9A	0002								P50H
4										
5	U759	9UP1							CH9U	3P76
6									8759	
7	0356	4868	41P4	748C	PHCC			5U3F		9H1H
8						UUUH				
9	1U5P	4FCA	31AC	8069	C6P1			1FH6	3P76	9H1P
10			36F8	U638	HC8A			8U95		
11			4685	9CPH	6P25			55F4	C898	9H1P
12	P763	6U28	20U0	359H	C898			79HU	65A5	65A5
13			18H7	H883	P26P			PU99		
14	8484	37C5	1C66	0A8U	89C7			1P50		FF4H
15			2340	5HP5	26H1				FF4H	
16	FFFF	6321							9H1H	8759
17										
18	UUUU	7791							9UP1	CH9U

ROM The ROM can be checked using signature analysis.

1. Set the microprocessor to free-run as described in “Free Running Signature Analysis” and connect the signature analyzer probes as given in Table 10.7-4.

**Table 10.7-4.
Signature Analyzer Probe connections for ROM Test**

Probe	Trigger	Connect to
Start	λ	See Table 10.7-5
Stop	f	See Table 10.7-5
Clock	λ	TP “E”
Ground		Ground

2. Connect the data probe to the +5 V supply (U40 pin 28) and check that the signature is P254. If not, the microprocessor is not free-running.
3. Use the data, start and stop probes to check the signatures given in Table 10.7-5:

Table 10.7-5. ROM U40 signatures

Data probe pin	Connect Start/Stop probes to U12 pin:					
	7	9	10	11	12	13
28	P254	P254	P254	P254	P254	P254
11	278A	P726	78H0	C343	A462	4005
12	9527	PPAC	85CF	UPU9	1UC1	UFF5
13	4731	U658	4048	PP66	94A4	2P43
15	U9H8	H7A7	3CH0	A230	C205	1FAU
16	6344	CP5F	C67H	FA76	5CCU	1F61
17	PCC0	9P52	CU03	4A01	HF66	H294
18	8P11	A30C	PH19	P9F7	5604	FC66
19	9A08	H5UU	9A0A	H6HP	4255	82PH

Changing the ROM

If the ROM is changed, the data saved in the RAM has to be made compatible with the new ROM. This can be done by setting the HP 8116A to an error condition (E.WID and SINE waveform, for example) and turning the instrument off and on again.

If the instrument becomes totally inoperable switch it off and disconnect the RAM back-up battery for at least 30 seconds. This will destroy the stored RAM data. Re-connect the RAM back-up battery and switch the instrument on. The Standard Parameter Set is now loaded into the RAM.

Keyboard

The keyboard can be checked using signature analysis:

1. Set the microprocessor to free-run as described in "Free Running Signature Analysis" and connect the signature analyzer probes as given in Table 10.7-2.
2. Connect the data probe to the +5 V supply (U40 pin 28) and check that the signature is 0003. If not, the microprocessor is not free-running.
3. Connect the data probe to TP7, on the microprocessor board A3, and check the signature obtained when each key is pressed against Table 10.7-6.

Table 10.7-6. Keyboard signatures

Key	TP7 Signature	
	Standard	Option 001
no key pressed	0003	6F80
LCL	9HP6	U165
MODE1 (NORM ...)	P28A	8P09
MODE2 (I.SWP ...)	—	9422
CTRL	3P2C	52A8
STA	—	630A
STP,RPT	—	PU62
SWT,BUR	—	4F78
FRQ,MRK	7CUC	1778
DTY,WID	5PUH	327P
HIL,AMP	F980	A503
LOL,OFS	3263	5PP0
-90°	677A	0CU9
<i>f</i>	99HH	U55P
\backslash	2674	4AU7
MAN	899P	P51H
1Cycle	—	FPP7
Sine	95PF	U96U
Triangle	P578	89UC
Square	795H	15HP
Pulse	P325	8UA6
AUTO	8F9C	P018
LIMIT	PUP0	8363
COMPL	UP31	92C2
DISABLE	CU8U	H30F
Vernier MSD UP	0P5P	62HH
Vernier MSD DOWN	975F	UCHU
Vernier middle UP	8394	PU17
Vernier middle DOWN	P5H4	8957
Vernier LSD UP	60P6	0F65
Vernier LSD DOWN	3976	55U5
RANGE UP	983A	U4C9
RANGE DOWN	260H	4A8P

P3 BD BY MICROPROCESSOR

A B C

MODEL HP8116R

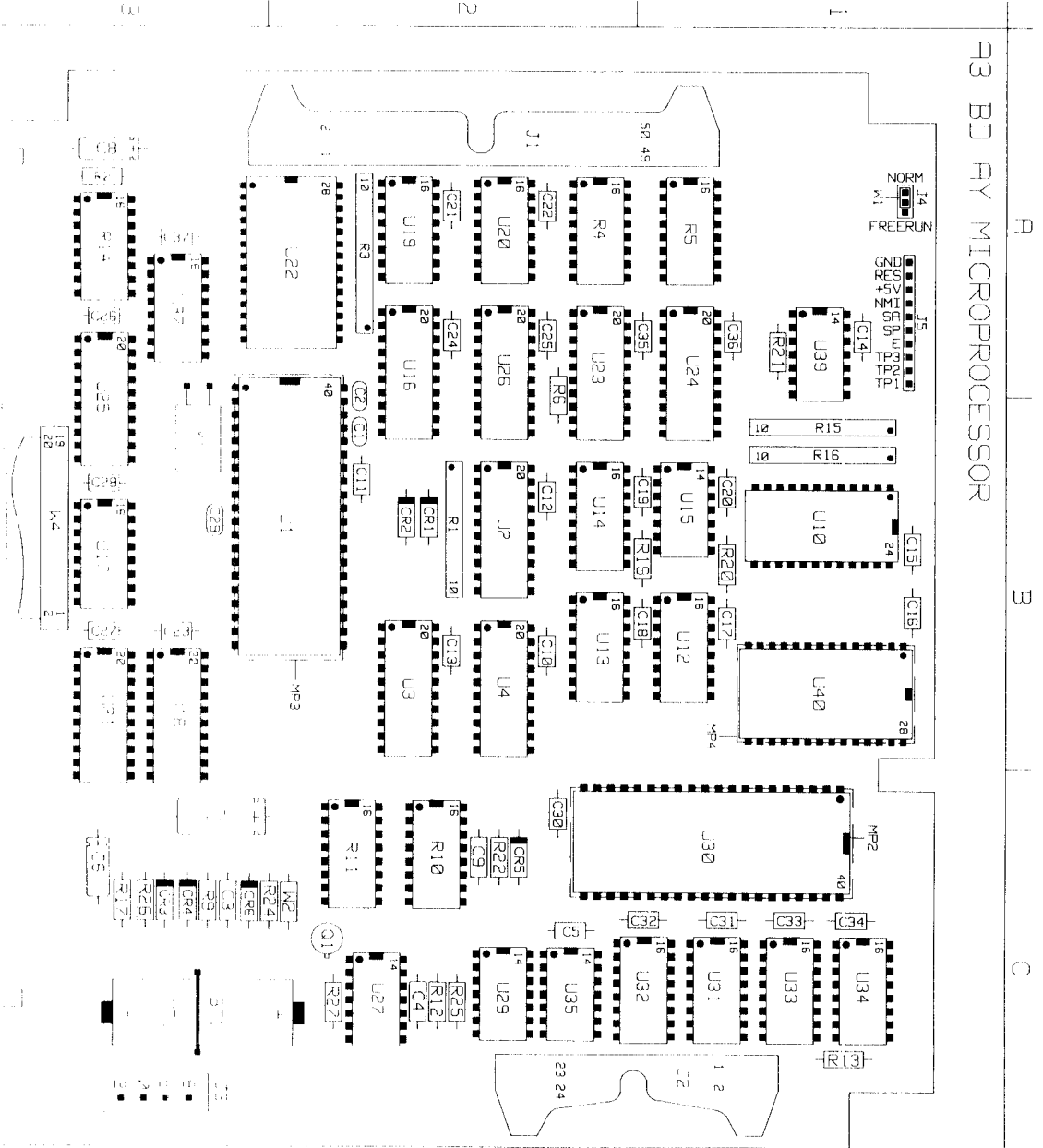

REF. DES.	GRID LOC.	REF. DES.	GRID LOC.
B71	C3	R4	R2
C1	B2	R5	R1
C2	R2	R6	R2
C3	C3	R9	C2
C4	C2	R10	C2
C5	C2	R11	C2
C6	C3	R12	C2
C7	C3	R13	C1
C8	C2	R14	R3
C9	C2	R15	B1
C10	B2	R16	B1
C11	B2	R17	B1
C12	B2	R18	B1
C13	B2	R19	B1
C14	R1	R20	R1
C15	R1	R21	R1
C16	B1	R22	C2
C17	B1	R23	C2
C18	B1	R24	C2
C19	B1	R25	C2
C20	B1	R26	C2
C21	R1	R27	C2
C22	B1	R28	B2
C23	R2	R29	B2
C24	R2	R30	B2
C25	R2	R31	B2
C26	R3	R32	B1
C27	B3	R33	B2
C28	B3	R34	B2
C29	B3	R35	B2
C30	B3	R36	B2
C31	C4	R37	R2
C32	C4	R38	R2
C33	C4	R39	R2
C34	C4	R40	R2
C35	C4	R41	R2
C36	R2	R42	B1
C37	B3	R43	B1
C38	B3	R44	B2
C39	B3	R45	B2
C40	B3	R46	B2
C41	C4	R47	B2
C42	C4	R48	B2
C43	C4	R49	B2
C44	C4	R50	B2
C45	C4	R51	B2
C46	C4	R52	B2
C47	C4	R53	B2
C48	C4	R54	B2
C49	C4	R55	B2
C50	C4	R56	B2
C51	C4	R57	B2
C52	C4	R58	B2
C53	C4	R59	B2
C54	C4	R60	B2
C55	C4	R61	B2
C56	C4	R62	B2
C57	C4	R63	B2
C58	C4	R64	B2
C59	C4	R65	B2
C60	C4	R66	B2
C61	C4	R67	B2
C62	C4	R68	B2
C63	C4	R69	B2
C64	C4	R70	B2
C65	C4	R71	B2
C66	C4	R72	B2
C67	C4	R73	B2
C68	C4	R74	B2
C69	C4	R75	B2
C70	C4	R76	B2
C71	C4	R77	B2
C72	C4	R78	B2
C73	C4	R79	B2
C74	C4	R80	B2
C75	C4	R81	B2
C76	C4	R82	B2
C77	C4	R83	B2
C78	C4	R84	B2
C79	C4	R85	B2
C80	C4	R86	B2
C81	C4	R87	B2
C82	C4	R88	B2
C83	C4	R89	B2
C84	C4	R90	B2
C85	C4	R91	B2
C86	C4	R92	B2
C87	C4	R93	B2
C88	C4	R94	B2
C89	C4	R95	B2
C90	C4	R96	B2
C91	C4	R97	B2
C92	C4	R98	B2
C93	C4	R99	B2
C94	C4	R100	B2
C95	C4	R101	B2
C96	C4	R102	B2
C97	C4	R103	B2
C98	C4	R104	B2
C99	C4	R105	B2
C100	C4	R106	B2

FIGURE 12.7-5. MICROPROCESSOR BOARD COMPONENT LAYOUT AND LOCATION

SERVICING THE MICROPROCESSOR AND PROM MANUAL 12.7-21

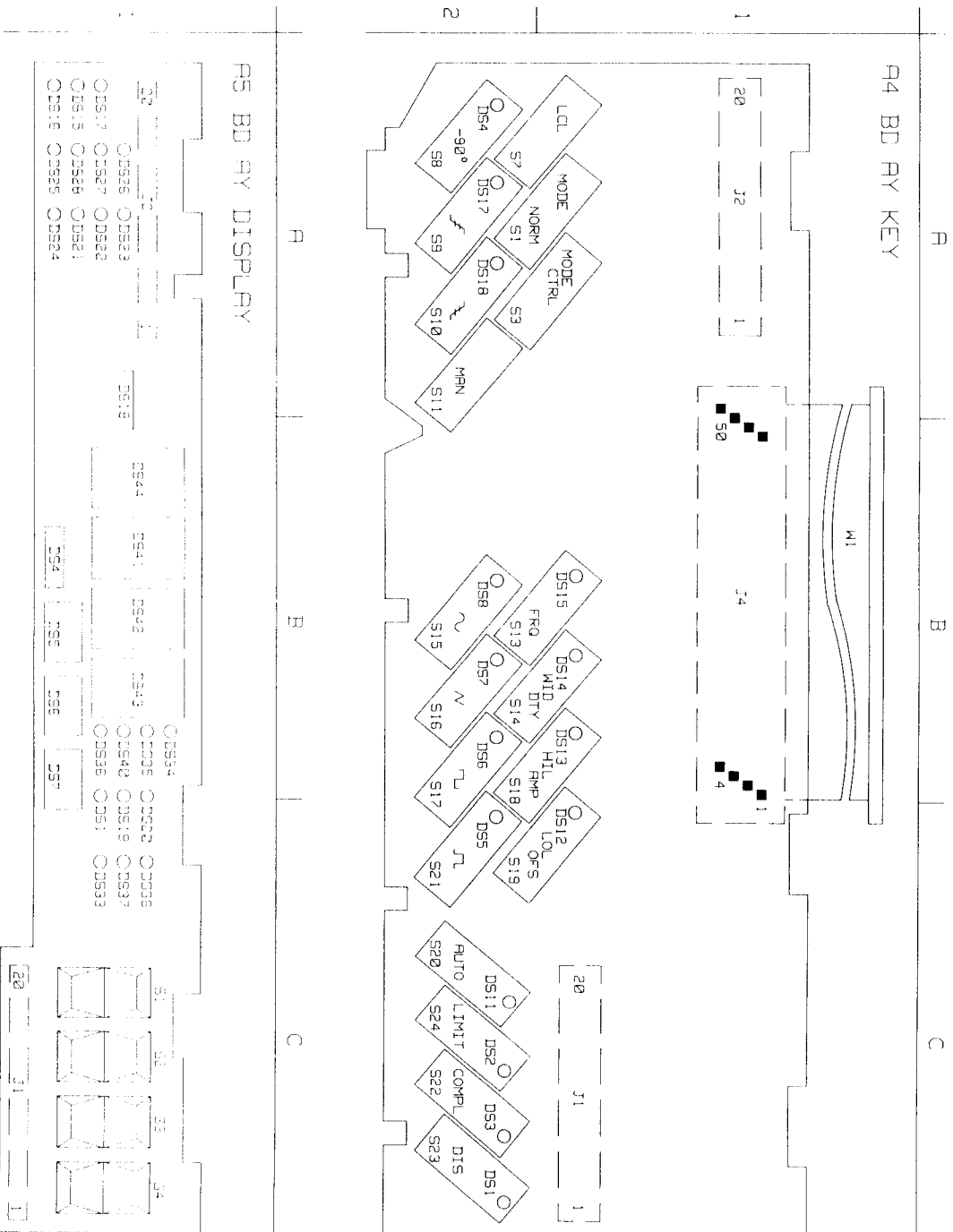

REF. DES.	GRID LOC.	REF. DES.	GRID LOC.
DS1	C2	DS33	C1
DS2	C2	DS34	B1
DS3	C2	DS35	B1
DS4	A2	DS36	B1
DS5	C2	DS37	C1
DS6	B2	DS38	B1
DS7	B2	DS40	B1
DS8	B2	DS41	B1
DS9	C1	DS42	B1
DS10	B2	DS43	R1
DS11	B2	DS44	R1
DS12	C1	DS45	R1
DS13	B1	DS46	R1
DS14	B1	DS47	R1
DS15	B1	DS48	R1
DS16	R2	DS49	R1
DS17	R2	DS50	R1
DS18	R2	DS51	R1
J1	A1	DS52	C2
J2	A1	DS53	C2
S1	R2	DS54	C2
S2	R2		
S3	R2		
S4	R2		
S5	R2		
S6	R2		
S7	R2		
S8	R2		
S9	R2		
S10	R2		
S11	R2		
S12	R2		
S13	R2		
S14	R2		
S15	R2		
S16	R2		
S17	R2		
S18	R2		
S19	R2		
S20	R2		
S21	R2		
S22	R2		
S23	R2		
S24	R2		
S25	R2		
S26	R2		
S27	R2		
S28	R2		
S29	R2		
S30	R2		
S31	R2		
S32	R2		
S33	R2		
S34	R2		
M1	B1		

FIGURE 10.7-10. KEYBOARD R4 AND DISPLAY BOARD R5 COMPONENT LAYOUTS AND LOCATIONS SERVING THE MICROPROCESSOR AND FRONT PANEL 10.7-23

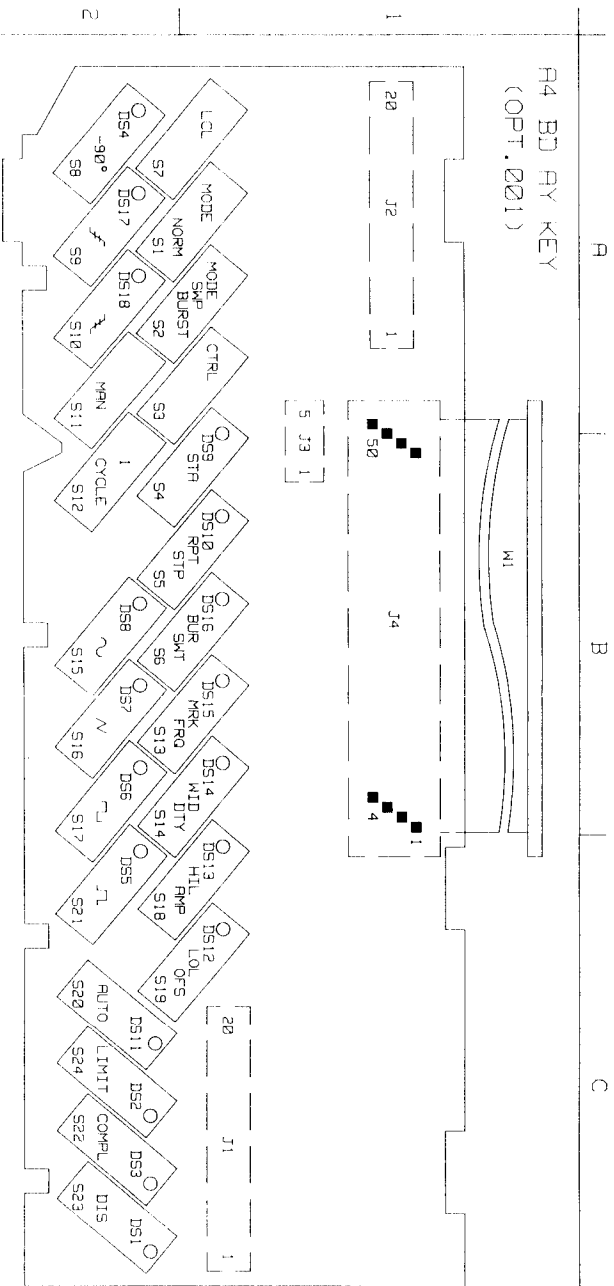

REF. DES.	GRID LOC.	REF. DES.	GRID LOC.
D51	C2	S14	B2
D52	C2	S15	B2
D53	C2	S16	B2
D54	C2	S17	B2
D55	C2	S18	B2
D56	B2	S19	C2
D57	B2	S20	C2
D58	B1	S21	C2
D59	B1	S22	C2
D60	B1	S23	C2
D61	C2	S24	C2
D62	C1	M1	B1
D63	B1		
D64	B1		
D65	B2		
D66	B2		
D67	B2		
D68	B2		
D69	B2		
D70	B2		
D71	B2		
D72	B2		
D73	B2		
D74	B2		
D75	B2		
D76	B2		
D77	B2		
D78	B2		
D79	B2		
D80	B2		
D81	B2		
D82	B2		
D83	B2		
D84	B2		
D85	B2		
D86	B2		
D87	B2		
D88	B2		
D89	B2		
D90	B2		
D91	B2		
D92	B2		
D93	B2		
D94	B2		
D95	B2		
D96	B2		
D97	B2		
D98	B2		
D99	B2		
D100	B2		

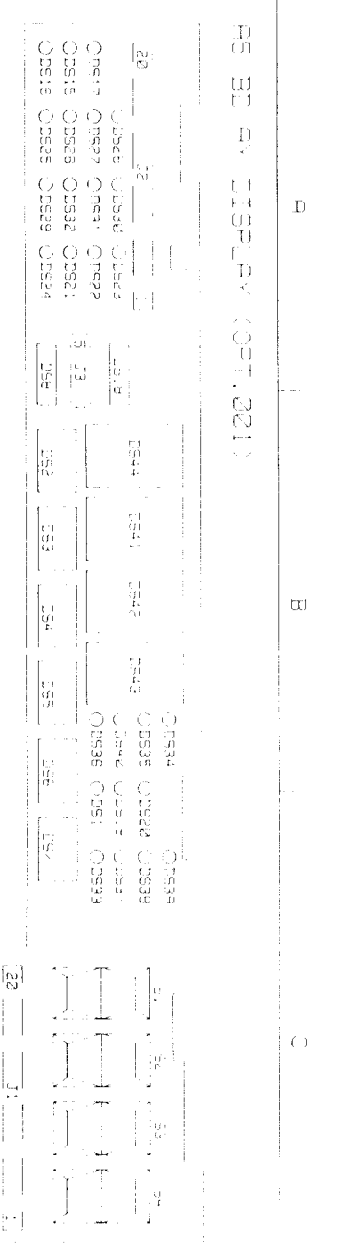

REF. DES.	GRID LOC.	REF. DES.	GRID LOC.
D101	C1	S25	B1
D102	B1	S26	B1
D103	B1	S27	B1
D104	B1	S28	B1
D105	B1	S29	B1
D106	B1	S30	B1
D107	B1	S31	B1
D108	B1	S32	B1
D109	B1	S33	B1
D110	B1	S34	B1
D111	B1	S35	B1
D112	B1	S36	B1
D113	B1	S37	B1
D114	B1	S38	B1
D115	B1	S39	B1
D116	B1	S40	B1
D117	B1	S41	B1
D118	B1	S42	B1
D119	B1	S43	B1
D120	B1	S44	B1
D121	B1	S45	B1
D122	B1	S46	B1
D123	B1	S47	B1
D124	B1	S48	B1
D125	B1	S49	B1
D126	B1	S50	B1
D127	B1	S51	B1
D128	B1	S52	B1
D129	B1	S53	B1
D130	B1	S54	B1
D131	B1	S55	B1
D132	B1	S56	B1
D133	B1	S57	B1
D134	B1	S58	B1
D135	B1	S59	B1
D136	B1	S60	B1
D137	B1	S61	B1
D138	B1	S62	B1
D139	B1	S63	B1
D140	B1	S64	B1
D141	B1	S65	B1
D142	B1	S66	B1
D143	B1	S67	B1
D144	B1	S68	B1
D145	B1	S69	B1
D146	B1	S70	B1
D147	B1	S71	B1
D148	B1	S72	B1
D149	B1	S73	B1
D150	B1	S74	B1
D151	B1	S75	B1
D152	B1	S76	B1
D153	B1	S77	B1
D154	B1	S78	B1
D155	B1	S79	B1
D156	B1	S80	B1
D157	B1	S81	B1
D158	B1	S82	B1
D159	B1	S83	B1
D160	B1	S84	B1
D161	B1	S85	B1
D162	B1	S86	B1
D163	B1	S87	B1
D164	B1	S88	B1
D165	B1	S89	B1
D166	B1	S90	B1
D167	B1	S91	B1
D168	B1	S92	B1
D169	B1	S93	B1
D170	B1	S94	B1
D171	B1	S95	B1
D172	B1	S96	B1
D173	B1	S97	B1
D174	B1	S98	B1
D175	B1	S99	B1
D176	B1	S100	B1

FIGURE 12-7-11. KEYBOARD R4 AND DISPLAY BOARD R5 COMPONENTS AND WIRE ROUTING (OPT. 021) SERVICING THE MICROPROCESSOR AND FRONT PANEL (12-7-25)

Replaceable Parts

Introduction

General This Appendix contains information for ordering all the replaceable parts contained in the HP 8116A. The parts-lists are divided into two groups. The first group covers the standard instrument, and contains a master parts-list followed by parts-lists for each of the electrical assemblies. The second group covers Option 001, and contains a master parts-list followed by parts-lists for the alternative electrical assemblies fitted to the Option 001 instrument.

The information given for each part consists of the following:

- The schematic and component layout reference.
- The Hewlett-Packard part-number.
- The part-number check-digit.
- The part's description.
- The Hewlett-Packard reference number for the part's manufacturer.
- The manufacturer's part-number.

A list of manufacturers and their Hewlett-Packard reference numbers is given in Table A-1. Figure A-1 and Figure A-2 identify the main mechanical parts of the instrument.

Ordering Parts To order a part listed in one of the parts-lists, you must quote the Hewlett-Packard part-number and check-digit, together with the quantity required, and send the order to the nearest Hewlett-Packard office. A list of Sales & Service offices is given in Appendix D.

If you require a part which is not listed in one of the parts-lists, then quote the instrument model-number, serial number, and the function/description of the part.

Within the USA you can use the Hewlett-Packard direct mail-order system. This offers the following advantages:

- Ordering and shipment are via the HP Parts Center in Mountain View, California.
- There is no maximum or minimum order value.
- A small handling charge means that all transportation is pre-paid.
- Payment must accompany the order, therefore there is no invoice processing.

The mail-order forms required to use this system are available from your local Hewlett-Packard office.

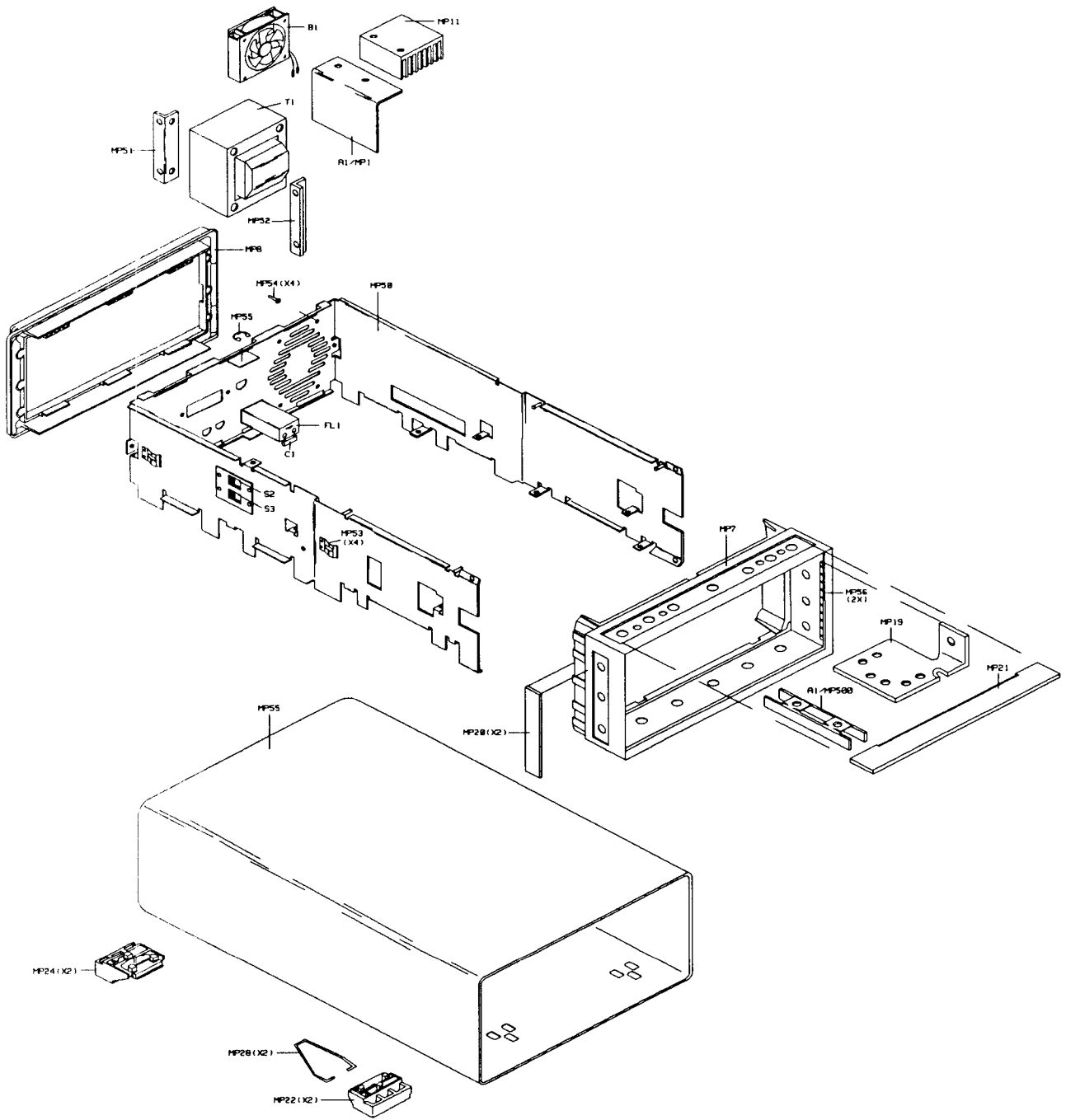

Figure A-1. Mechanical Parts - 1

A-2 Replaceable Parts

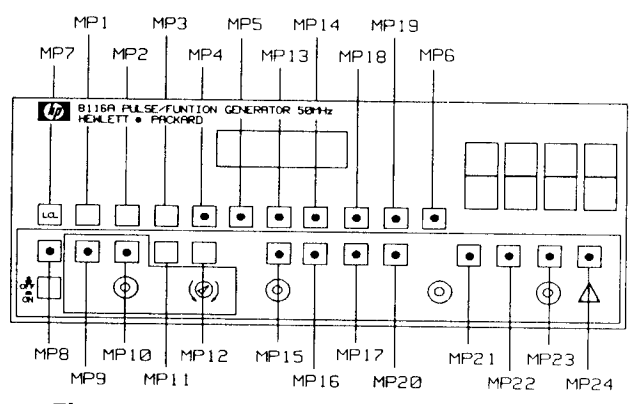
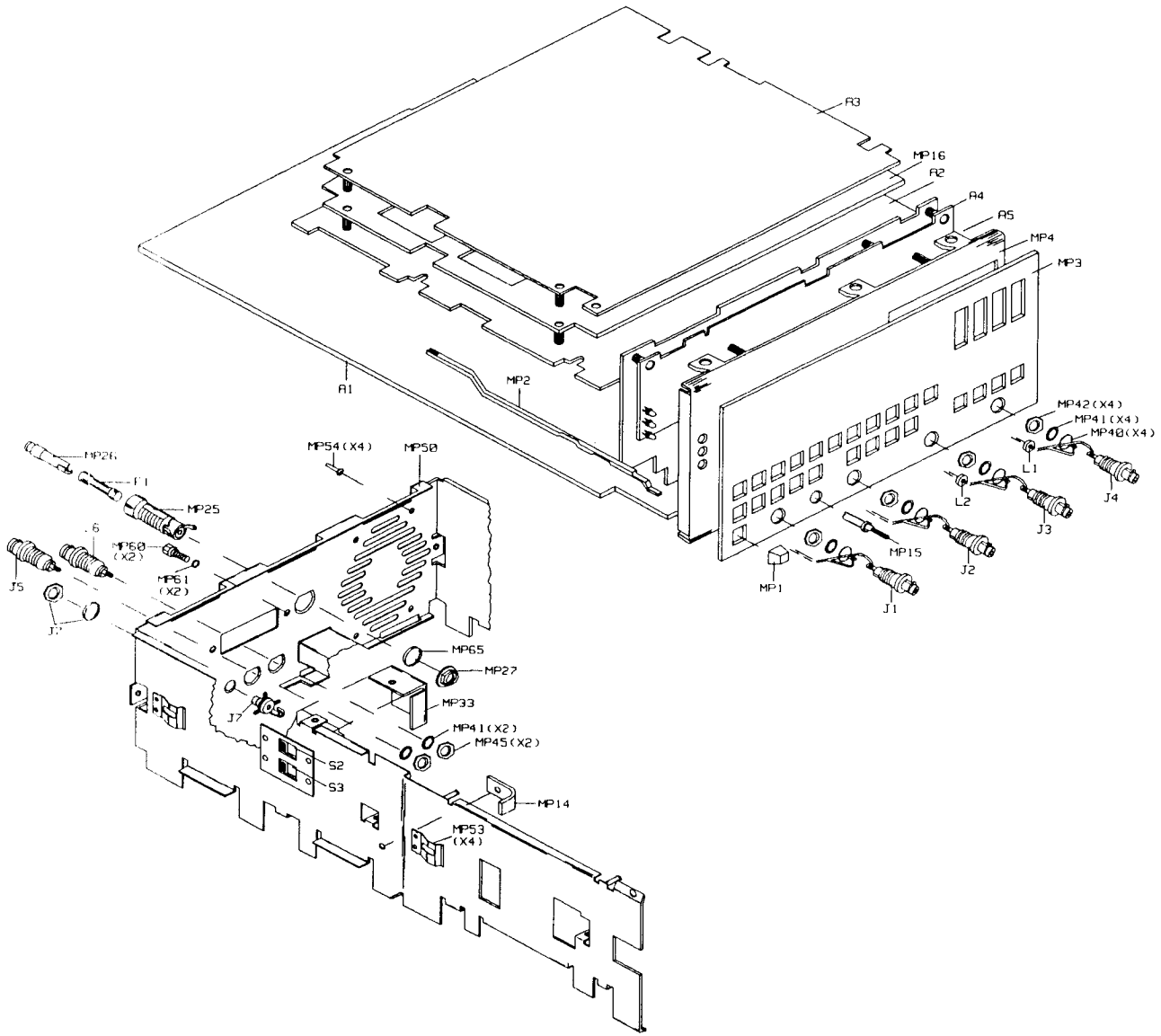

Figure A-2. Mechanical Parts - 2

Table A-1. Key to HP Manufacturer References

Reference	Name	Reference	Name
00359	O'HARA METAL PRODUCTS CO	04504	GENERAL INSTRUMENT CORP
00493	UNITED CHEMI-CON INC	04568	BECKMAN INDUSTRIAL CORP
01074	MEGGITT-ELECTRONIC COMPONENTS LTD	04604	FEDERAL SCREW PRODUCTS CO
01339	GETTIG ENGRG & MFG CO INC	04605	FISCHER SPECIAL MFG CO
01380	AMP INC	04703	LITTELFUSE INC
01542	HP DIV 01 SAN JOSE COMPONENTS	04726	3M CO
01607	ALLEN-BRADLEY CO INC	04805	ILLINOIS TOOL WORKS INC SHAKEPROOF
01698	TEXAS INSTRUMENTS INC	04822	STACKPOLE CARBON CO
01876	HP DIV 02 SCD IC'S	04880	ZIERICK MFG CO
02010	AVX CORP	04939	SCHNITZER ALLOY PRODUCTS CO
02037	MOTOROLA INC	05131	ELECTRONIC DEVICES INC
02062	HP DIV 05 MSD	05524	DALE ELECTRONICS INC
02123	EG & G INC	05584	DURALITH CORP
02180	PRECISION MONOLITHICS INC	05610	CAMCAR SCREW & MFG CO
02367	CORNELL-DUBILIER/SANGAMO	05879	AMPHENOL CORPORATION
02414	BURNDY CORP	05912	RUDOLF SCHADOW GMBH
02483	CTS CORP	05959	MARQUARDT GMBH
02499	IRC INC	05992	EFCO COMPOSANTS
02582	CLAROSTAT MFG CO INC	06121	SIEMENS AG
02608	THERMALLOY INC	06307	SCHAFFNER AG
02685	LOBAUGH ROLLIN J	06328	SCHURTER AG
02688	MICROSEMI CORP	06330	CONDENSATEURS FRIBOURG S A
02910	SIGNETICS CORP	06337	PHILIPS GLOEILAMPENFABRIEKEN N V
02946	DUPONT E I DE NEMOURS & CO	06352	TDK CORPORATION OF AMERICA
03273	GOWANDA ELECTRONICS CORP	07492	ELECTRO DYNAMICS CORP
03285	ANALOG DEVICES INC	08360	DAUT + RIETZ GMBH & CO KG
03406	NATIONAL SEMICONDUCTOR CORP	08709	PANASONIC INDUSTRIAL CO
03418	MOLEX INC	08839	COMATEL
03647	INSTRUMENT SPECIALTIES CO INC	09538	TUSONIX
03744	BOURNS NETWORKS INC	09939	MURATA ERIE NORTH AMERICA INC
03799	HARRIS CORP	10358	VOGT AG
03827	FAIR RITE PRODUCTS CORP	11039	PAPST MECHATRONIC CORP
04200	SPRAGUE ELECTRIC CO	11127	H. ZEHNDER
04225	THOMAS & BETTS CORP	11263	W GUNTHER GMBH
04486	ITT CORP	11892	EVOX/RIFA INC
		11904	GEBRUEDER FREI GMBH & CO
		12482	BRADFORD ELECTRONICS INC
		28480	HEWLETT PACKARD COMPANY

Standard Instrument Parts-lists

Master List

Table A-2. Standard HP 8116A Parts List

Reference	HP Part #	CD	Qty	Description	Manuf'r	Part #
A0	PULS6	0	1	DUMMY 8116	28480	PULS6
A0 A1	08116-66541	3	1	BD AY-MAIN	28480	08116-66541
A0 A2	08116-66522	0	1	BD AY-CONTROL	28480	08116-66522
A0 A3	08116-66535	5	1	BD AY-MICROPROCR	28480	08116-66535
A0 A4	08116-66504	8	1	BD AY-KEY	28480	08116-66504
A0 A5	08116-66505	9	1	BD AY-DISPLAY	28480	08116-66505
A0 B1	3160-0497	2	1	FAN-TBAX	11039	612
A0 C1	0160-4323	8	1	CAP 0.047uF 0 V	11892	PME271M547M
A0 F1	2110-0043	8	1	FUSE 1.5A 250V	04703	312 01.5
A0 FL1	9135-0035	7		FLTR-LINE	06307	FU 1606
A0 J1	1250-0083	1	1	CONN-RF BNC	05879	31-221-1020
A0 J2	1250-0083	1	1	CONN-RF BNC	05879	31-221-1020
A0 J3	1250-0083	1	1	CONN-RF BNC	05879	31-221-1020
A0 J4	1250-0083	1	1	CONN-RF BNC	05879	31-221-1020
A0 L1	9170-0013	5	1	CORE-TOROID	03827	5943000201
A0 L2	9170-0013	5	1	CORE-TOROID	03827	5943000201
A0 MP1	5041-0531	5	1	KEY	28480	5041-0531
A0 MP2	5040-9317	1	1	SHAFT-POWER SW	28480	5040-9317
A0 MP3	4040-1972	7	1	LABEL-INFO	05584	
A0 MP4	08116-00205	8	1	PNL SUB	28480	08116-00205
A0 MP7	5021-8413	6	1	FRAME FRONT	28480	5021-8413
A0 MP11	08116-21107	3	1		28480	08116-21107
A0 MP14	08116-04154	4	1	KEEPER	28480	08116-04154
A0 MP15	5040-1136	6	1	KNOB LONG	28480	5040-1136
A0 MP16	08112-00601	4	1	SHEILD	28480	08112-00601
A0 MP19	08116-21102	8	1	HEATSINK OUTPUT	28480	08116-21102
A0 MP20	5001-0538	8	1	TRIM STRIP	28480	5001-0538
A0 MP21	5041-8803	0	1	TRIM STRIP	28480	5041-8803
A0 MP22	5041-8801	8	1	FOOT	28480	5041-8801
A0 MP24	5041-8822	3	1	FOOT REAR NON-SKID	28480	5041-8822

Table A-2. Standard HP 8116A Parts List (continued)

Reference	HP Part #	CD	Qty	Description	Manuf'r	Part #
A0 MP26	2110-0565	9	1	FUSEHOLDER CAP	06328	031.1666
A0 MP27	2110-0569	3	1	FUHLR-CMPNT	06328	098.0043
A0 MP28	1460-1345	5	1	TILT STAND	00359	
A0 MP33	08116-40601	2	1		28480	08116-40601
A0 MP40	0360-1190	5	1	TERM-SOLDER LUG	04880	720-.380H
A0 MP41	2190-0016	3	1	WSHR-LK INTL T	04805	1920-02
A0 MP42	2950-0043	8	1	NUT-HEX-DBL-CHAM	04605	28200-10-101
A0 MP50	08116-60101	9	1	CHASSIS	28480	08116-60101
A0 MP51	08116-01203	8	1	BRACKET-XFMR	28480	08116-01203
A0 MP52	08116-01201	6	1	BRACKET-XFMR	28480	08116-01201
A0 MP53	E1222-09102	4		SPRING CONTACT	28480	E1222-09102
A0 MP54	0624-0413	3	1	SCR-TPG 8-16	05610	224-41390-382
A0 MP55	08116-04123	7	1	COVER	28480	08116-04123
A0 MP56	0363-0125	0		RFI STRP-FINGERS	03647	97-555
A0 MP60	0380-1482	0	1	STDF-HEX .34-IN	02685	
A0 MP61	2190-0073	2	1	WSHR-LK HLCL	04939	
A0 MP65	1400-0090	9	1	FUHLR-CMPNT	04703	901-002
A0 S2	3101-2298	1		SW-SL DPDT	05959	4021.0214
A0 S3	3101-2298	1		SW-SL DPDT	05959	4021.0214
A0 T1	9100-4913	5	1	XFMR-PWR	11904	

Main Board

Table A-3. Standard HP 8116A Main Board Parts List

Reference	HP Part #	CD	Qty	Description	Manuf'r	Part #
A1	08116-66541	3	1	BD AY MAIN	28480	08116-66541
A1 C1	0180-3159	8	1	CAP 25 V	00493	NM25VN103Q25X51
A1 C2	0180-3158	7	1	CAP 6800uF 16 V	00493	NM16VN682Q22X41
A1 C3	0180-3160	1	1	CAP 2200uF 50 V	00493	NM50VN222Q22X41
A1 C4	0180-3160	1	1	CAP 2200uF 50 V	00493	NM50VN222Q22X41
A1 C5	0180-4313	8	1	CAP 2200uF 50 V	00493	KME50VB222M18X35LL
A1 C6	0180-3008	6	1	CAP 470uF 35 V	04200	502D477F035EG1D
A1 C7	0180-2984	5	1	CAP 47uF 50 V	00493	SM50VB47R(M)8X11
A1 C8	0180-2984	5	1	CAP 47uF 50 V	00493	SM50VB47R(M)8X11
A1 C9	0180-2984	5	1	CAP 47uF 50 V	00493	SM50VB47R(M)8X11
A1 C10	0180-2984	5	1	CAP 47uF 50 V	00493	SM50VB47R(M)8X11
A1 C11	0180-2962	9	1	CAP 220uF 10 V	00493	SL10VB221T10X16
A1 C12	0180-2962	9	1	CAP 220uF 10 V	00493	SL10VB221T10X16
A1 C13	0180-2962	9	1	CAP 220uF 10 V	00493	SL10VB221T10X16
A1 C14	0160-2055	9	1	CAP 0.01uF 100 V	09538	805-504 Y5V 103Z
A1 C15	0160-2055	9	1	CAP 0.01uF 100 V	09538	805-504 Y5V 103Z
A1 C16	0160-2055	9	1	CAP 0.01uF 100 V	09538	805-504 Y5V 103Z
A1 C17	0160-2055	9	1	CAP 0.01uF 100 V	09538	805-504 Y5V 103Z
A1 C18	0160-6596	1	1	CAP 0.47uF 50 V	02010	SA305E474MAAH
A1 C19	0160-6596	1	1	CAP 0.47uF 50 V	02010	SA305E474MAAH
A1 C20	0160-3508	9	1	CAP 1uF 50 V	02010	SR305E105ZAAH
A1 C21	0160-3879	7	1	CAP 0.01uF 100 V	02010	SR201C103MAAH
A1 C100	0160-5746	1	1	CAP 0.1uF 50 V	06121	B37987-T5104-M11
A1 C101	0160-5746	1	1	CAP 0.1uF 50 V	06121	B37987-T5104-M11
A1 C102	0160-6596	1	1	CAP 0.47uF 50 V	02010	SA305E474MAAH
A1 C103	0160-5746	1	1	CAP 0.1uF 50 V	06121	B37987-T5104-M11
A1 C104	0160-0571	0	1	CAP 470pF 100 V	02010	SR201C471MAAH
A1 C105	0160-6596	1	1	CAP 0.47uF 50 V	02010	SA305E474MAAH
A1 C106	0160-5746	1	1	CAP 0.1uF 50 V	06121	B37987-T5104-M11
A1 C107	0180-0229	7	1	CAP 33uF 10 V	04200	150D336X9010B2-DYS

Table A-3. Standard HP 8116A Main Board Parts List (continued)

Reference	HP Part #	CD	Qty	Description	Manuf'r	Part #
A1 C108	0160-5746	1	1	CAP 0.1uF 50 V	06121	B37987-T5104-M11
A1 C110	0160-6596	1	1	CAP 0.47uF 50 V	02010	SA305E474MAAH
A1 C112	0180-2249	5	1	CAP 47uF 20 V	04200	150D476X9020R2-DYS
A1 C113	0180-2249	5	1	CAP 47uF 20 V	04200	150D476X9020R2-DYS
A1 C114	0180-0229	7	1	CAP 33uF 10 V	04200	150D336X9010B2-DYS
A1 C115	0180-0229	7	1	CAP 33uF 10 V	04200	150D336X9010B2-DYS
A1 C151	0160-3873	1	1	CAP 4.7pF 200 V	06352	FD12C0G2D4R7D
A1 C152	0160-5746	1	1	CAP 0.1uF 50 V	06121	B37987-T5104-M11
A1 C153	0160-5746	1	1	CAP 0.1uF 50 V	06121	B37987-T5104-M11
A1 C154	0160-4387	4	1	CAP 47pF 200 V	06352	FD12C0G2D470J
A1 C200	0160-3878	6	1	CAP 1000pF 100 V	02010	SR201C102MAAH
A1 C201	0160-3878	6	1	CAP 1000pF 100 V	02010	SR201C102MAAH
A1 C202	0160-3879	7	1	CAP 0.01uF 100 V	02010	SR201C103MAAH
A1 C204	0121-0046	2	1	CAP 35pF 9pF 200	09538	538-016 D 9-35
A1 C205	0160-4318	1	1	CAP 330pF 500 V	02367	CD15FD331FO3
A1 C206	0160-2675	9	1	CAP 3900pF 300 V	02367	CD19.5FD392FO3
A1 C207	0160-5426	4	1	CAP 0.039uF 63 V	06330	BG1PM 4390F
A1 C208	0160-5424	2	1	CAP 0.39uF 40 V	06330	IOGIPM5390F
A1 C209	0160-3726	3	1	CAP 1uF 40 V	05992	23110550
A1 C210	0160-3839	9	1	CAP 2.2uF 40 V	05992	23122550
A1 C211	0160-0572	1	1	CAP 2200pF 100 V	02010	SR201C222MAAH
A1 C212	0160-5746	1	1	CAP 0.1uF 50 V	06121	B37987-T5104-M11
A1 C213	0160-6596	1	1	CAP 0.47uF 50 V	02010	SA305E474MAAH
A1 C214	0160-5746	1	1	CAP 0.1uF 50 V	06121	B37987-T5104-M11
A1 C215	0160-5746	1	1	CAP 0.1uF 50 V	06121	B37987-T5104-M11
A1 C216	0160-4383	0	1	CAP 6.8pF 200 V	06352	FD12C0G2D6R8D
A1 C217	0160-3874	2	1	CAP 10pF 200 V	06352	FD12C0G2D100D
A1 C220	0160-5746	1	1	CAP 0.1uF 50 V	06121	B37987-T5104-M11
A1 C221	0160-3878	6	1	CAP 1000pF 100 V	02010	SR201C102MAAH
A1 C222	0160-3878	6	1	CAP 1000pF 100 V	02010	SR201C102MAAH

Table A-3.
Standard HP 8116A Main Board Parts List (continued)

Reference	HP Part #	CD	Qty	Description	Manuf'r	Part #
A1 C223	0160-4383	0	1	CAP 6.8pF 200 V	06352	FD12C0G2D6R8D
A1 C224	0160-5746	1	1	CAP 0.1uF 50 V	06121	B37987-T5104-M11
A1 C225	0160-3878	6	1	CAP 1000pF 100 V	02010	SR201C102MAAH
A1 C226	0160-6596	1	1	CAP 0.47uF 50 V	02010	SA305E474MAAH
A1 C227	0160-6596	1	1	CAP 0.47uF 50 V	02010	SA305E474MAAH
A1 C230*	0160-4386	3		CAP 33pF 200 V	02010	SR152A330JAA
A1 C231	0160-5746	1	1	CAP 0.1uF 50 V	06121	B37987-T5104-M11
A1 C235*	0160-3874	2	1	CAP 10pF 200 V	06352	FD12C0G2D100D
A1 C240	0160-6596	1	1	CAP 0.47uF 50 V	02010	SA305E474MAAH
A1 C241	0160-5746	1	1	CAP 0.1uF 50 V	06121	B37987-T5104-M11
A1 C260	0160-5746	1	1	CAP 0.1uF 50 V	06121	B37987-T5104-M11
A1 C261	0160-5746	1	1	CAP 0.1uF 50 V	06121	B37987-T5104-M11
A1 C262	0160-3879	7	1	CAP 0.01uF 100 V	02010	SR201C103MAAH
A1 C263	0160-5746	1	1	CAP 0.1uF 50 V	06121	B37987-T5104-M11
A1 C264*	0160-3878	6	1	CAP 1000pF 100V	02010	SR201C102MAAH
A1 C300*	0160-3874	2		CAP 10pF 200 V	06352	FD12C0G2D100D
A1 C301	0160-5746	1	1	CAP 0.1uF 50 V	06121	B37987-T5104-M11
A1 C302	0160-5746	1	1	CAP 0.1uF 50 V	06121	B37987-T5104-M11
A1 C303	0160-3879	7	1	CAP 0.01uF 100 V	02010	SR201C103MAAH
A1 C304	0160-3878	6	1	CAP 1000pF 100 V	02010	SR201C102MAAH
A1 C306	0160-0575	4	1	CAP 0.047uF 50 V	02010	SR205C473MAAH
A1 C307	0160-0575	4	1	CAP 0.047uF 50 V	02010	SR205C473MAAH
A1 C400	0160-3879	7	1	CAP 0.01uF 100 V	02010	SR201C103MAAH
A1 C401	0160-0572	1	1	CAP 2200pF 100 V	02010	SR201C222MAAH
A1 C402	0160-6596	1	1	CAP 0.47uF 50 V	02010	SA305E474MAAH
A1 C403	0160-5746	1	1	CAP 0.1uF 50 V	06121	B37987-T5104-M11
A1 C404	0160-6596	1	1	CAP 0.47uF 50 V	02010	SA305E474MAAH
A1 C405	0160-5746	1	1	CAP 0.1uF 50 V	06121	B37987-T5104-M11
A1 C406	0160-4512	7	1	CAP 120pF 200 V	02010	SR202A121JAAH
A1 C408	0160-5746	1	1	CAP 0.1uF 50 V	06121	B37987-T5104-M11
A1 C409*	0160-5739	2		CAP 15pF 100 V	06121	B37979-J1150-J034
A1 C410	0160-5746	1	1	CAP 0.1uF 50 V	06121	B37987-T5104-M11
A1 C501	0160-0574	3	1	CAP 0.022uF 100	02010	SR201C223MAAH

Table A-3.
Standard HP 8116A Main Board Parts List (continued)

Reference	HP Part #	CD	Qty	Description	Manuf'r	Part #
A1 C502*	0160-4350	1		CAP 68pF 200 V	06352	FD12C0G2D680J
A1 C503	0160-6596	1	1	CAP 0.47uF 50 V	02010	SA305E474MAAH
A1 C504	0160-6596	1	1	CAP 0.47uF 50 V	02010	SA305E474MAAH
A1 C505*	0160-3879	7	1	CAP 0.01uF 100 V	02010	SR201C103MAAH
A1 C506	0160-0572	1	1	CAP 2200pF 100 V	02010	SR201C222MAAH
A1 C507	0160-6596	1	1	CAP 0.47uF 50 V	02010	SA305E474MAAH
A1 C508	0160-6596	1	1	CAP 0.47uF 50 V	02010	SA305E474MAAH
A1 C509	0160-0573	2	1	CAP 4700pF 100 V	02010	SR201C472MAAH
A1 C510	0160-0573	2	1	CAP 4700pF 100 V	02010	SR201C472MAAH
A1 C511	0160-3879	7	1	CAP 0.01uF 100 V	02010	SR201C103MAAH
A1 C512	0160-5746	1	1	CAP 0.1uF 50 V	06121	B37987-T5104-M11
A1 C513	0160-5746	1	1	CAP 0.1uF 50 V	06121	B37987-T5104-M11
A1 C514	0160-5746	1	1	CAP 0.1uF 50 V	06121	B37987-T5104-M11
A1 C515	0160-5746	1	1	CAP 0.1uF 50 V	06121	B37987-T5104-M11
A1 C516	0160-5746	1	1	CAP 0.1uF 50 V	06121	B37987-T5104-M11
A1 C517	0160-5746	1	1	CAP 0.1uF 50 V	06121	B37987-T5104-M11
A1 C518	0160-5746	1	1	CAP 0.1uF 50 V	06121	B37987-T5104-M11
A1 C519	0160-6596	1	1	CAP 0.47uF 50 V	02010	SA305E474MAAH
A1 C520	0160-6596	1	1	CAP 0.47uF 50 V	02010	SA305E474MAAH
A1 C521	0160-6596	1	1	CAP 0.47uF 50 V	02010	SA305E474MAAH
A1 C522	0160-6596	1	1	CAP 0.47uF 50 V	02010	SA305E474MAAH
A1 C523	0180-0582	5	1	CAP 270uF 40 V	04200	672D277H040DT4C
A1 C524	0180-0582	5	1	CAP 270uF 40 V	04200	672D277H040DT4C
A1 C525*	0160-3874	2		CAP 10pF 200 V	06352	FD12C0G2D100D
A1 C526	0160-5746	1	1	CAP 0.1uF 50 V	06121	B37987-T5104-M11
A1 C527*	0160-4350	1	1	CAP 68pF 200 V	06352	FD12C0G2D680J
A1 C528*	0160-4380	7	1	CAP 1pF 200 V	06352	FD11C0K2D1R0C
A1 C529	0121-0466	0	1	CAP 3pF 1pF 100	09538	518-003 A 1-3
A1 C530*	0160-4380	7	1	CAP 1pF 200 V	06352	FD11C0K2D1R0C
A1 C531*	0160-4382	9	1	CAP 3.3pF 200 V	06352	FD12C0G2D3R3C
A1 C533	0160-5746	1	1	CAP 0.1uF 50 V	06121	B37987-T5104-M11
A1 C534	0160-5746	1	1	CAP 0.1uF 50 V	06121	B37987-T5104-M11

Table A-3. Standard HP 8116A Main Board Parts List (continued)

Reference	HP Part #	CD	Qty	Description	Manuf'r	Part #
A1 C535	0160-5746	1	1	CAP 0.1uF 50 V	06121	B37987-T5104-M11
A1 C536	0160-5746	1	1	CAP 0.1uF 50 V	06121	B37987-T5104-M11
A1 C537	0160-5746	1	1	CAP 0.1uF 50 V	06121	B37987-T5104-M11
A1 C538*	0160-3568	1	1	CAP 2.7pF 200 V	06352	
A1 C539*	0160-4386	3	1	CAP 33pF 200 V	02010	SR152A
A1 C540	0160-5746	1	1	CAP 0.1uF 50 V	06121	B37987-T5104-M11
A1 C541	0160-3879	7	1	CAP 0.01uF 100 V	02010	SR201C103MAAH
A1 C550	0160-5746	1	1	CAP 0.1uF 50 V	06121	B37987-T5104-M11
A1 C551*	0160-3873	1	1	CAP 4.7pF 200 V	06352	FD12C0G2D4R7D
A1 C552	0160-4381	8	1	CAP 1.5pF 200 V	06352	FD11C0G2D1R5C
A1 C553*	0160-4399	8	1	CAP 0.66pF 50 V	02010	
A1 C554*	0160-5730	3	1	CAP 100pF 100 V	06121	B37979-J1101-J034
A1 C555*	0160-3874	2		CAP 10pF 200 V	06352	FD12C0G2D100D
A1 C556*	0160-5730	3	1	CAP 100pF 100 V	06121	B37979-J1101-J034
A1 C557*	0160-4380	7	1	CAP 1pF 200 V	06352	FD11C0K2D1R0C
A1 CR1	1901-0638	3	1	DIO-FW BRDG 100V	04504	KBU4B
A1 CR2	1906-0096	7	1	DIO-FW BRDG 200V	05131	
A1 CR3	1906-0096	7	1	DIO-FW BRDG 200V	05131	
A1 CR4	1901-1098	1	1	DIO-1N4150	04486	
A1 CR5	1901-1098	1	1	DIO-1N4150	04486	
A1 CR6	1901-1098	1	1	DIO-1N4150	04486	
A1 CR7	1901-1098	1	1	DIO-1N4150	04486	
A1 CR8	1901-1098	1	1	DIO-1N4150	04486	
A1 CR9	1901-1098	1	1	DIO-1N4150	04486	
A1 CR10	1901-0050	3	1	DIO-SWITCHING	03406	
A1 CR11	1901-0050	3	1	DIO-SWITCHING	03406	
A1 CR12	1901-0050	3	1	DIO-SWITCHING	03406	
A1 CR101	1901-0539	3	1	DIO- SCHOTTKY SM	02062	50825510
A1 CR151	1901-1098	1	1	DIO-1N4150	04486	
A1 CR152	1901-1098	1	1	DIO-1N4150	04486	
A1 CR153	1901-0539	3	1	DIO- SCHOTTKY SM	02062	50825510
A1 CR154	1901-0539	3	1	DIO- SCHOTTKY SM	02062	50825510
A1 CR203	1901-0539	3	1	DIO- SCHOTTKY SM	02062	50825510
A1 CR204	1901-0539	3	1	DIO- SCHOTTKY SM	02062	50825510
A1 CR300	1901-1098	1	1	DIO-1N4150	04486	
A1 CR301	1901-1098	1	1	DIO-1N4150	04486	
A1 CR302	1901-1098	1	1	DIO-1N4150	04486	

Table A-3.
Standard HP 8116A Main Board Parts List (continued)

Reference	HP Part #	CD	Qty	Description	Manuf'r	Part #
A1 CR303	1901-1068	5	1	DIO- SCHOTTKY SM	02062	5082-5541
A1 CR304	1901-1068	5	1	DIO- SCHOTTKY SM	02062	5082-5541
A1 CR401	1901-0518	8	1	DIO- SCHOTTKY SM	02062	5082-5509
A1 CR402	1901-0518	8	1	DIO- SCHOTTKY SM	02062	5082-5509
A1 CR501	1901-0179	7	1	DIO-SWITCHING	03406	FD777
A1 CR502	1901-0179	7	1	DIO-SWITCHING	03406	FD777
A1 CR503	1901-0179	7	1	DIO-SWITCHING	03406	FD777
A1 CR504	1901-0179	7	1	DIO-SWITCHING	03406	FD777
A1 CR505	1901-0050	3	1	DIO-SWITCHING	03406	
A1 CR506	1901-0050	3	1	DIO-SWITCHING	03406	
A1 CR513	1901-0050	3	1	DIO-SWITCHING	03406	
A1 CR514	1901-0050	3	1	DIO-SWITCHING	03406	
A1 J1	1251-5184	5	1	CONN-POST-TP-HDR	03418	26-60-0070
A1 J2	1252-0277	9	1	CONN-POST-TP-HDR	04726	3428-6202
A1 J3	1251-3305	8	1	CONN-POST-TP-HDR	03418	26-60-1040
A1 K201	0490-1412	9	1	RLY-REED 1A	11263	3570.1332.053
A1 K202	0490-1412	9	1	RLY-REED 1A	11263	3570.1332.053
A1 K501	0490-1412	9	1	RLY-REED 1A	11263	3570.1332.053
A1 K502	0490-1412	9	1	RLY-REED 1A	11263	3570.1332.053
A1 K503	0490-1412	9	1	RLY-REED 1A	11263	3570.1332.053
A1 K504	0490-1412	9	1	RLY-REED 1A	11263	3570.1332.053
A1 K505	0490-1412	9	1	RLY-REED 1A	11263	3570.1332.053
A1 K506	0490-1412	9	1	RLY-REED 1A	11263	3570.1332.053
A1 L100	9170-0894	0	1	CORE-SHLD BEAD	06337	56-590-65/4A6
A1 L101	9170-0894	0	1	CORE-SHLD BEAD	06337	56-590-65/4A6
A1 L102	9170-0894	0	1	CORE-SHLD BEAD	06337	56-590-65/4A6
A1 L103	9170-0894	0	1	CORE-SHLD BEAD	06337	56-590-65/4A6
A1 L260	9100-2255	4	1	L 470NH +-10%	03273	10M470K
A1 L300	9170-0894	0	1	CORE-SHLD BEAD	06337	56-590-65/4A6
A1 L301	9170-0894	0	1	CORE-SHLD BEAD	06337	56-590-65/4A6

Table A-3. Standard HP 8116A Main Board Parts List (continued)

Reference	HP Part #	CD	Qty	Description	Manuf'r	Part #
A1 L500	9170-0894	0	1	CORE-SHLD BEAD	06337	56-590-65/4A6
A1 L501	9170-0894	0	1	CORE-SHLD BEAD	06337	56-590-65/4A6
A1 L502*	9170-0894	0	1	CORE-SHLD BEAD	06337	56-590-65/4A6
A1 L503*	9170-0894	0	1	CORE-SHLD BEAD	06337	56-590-65/4A6
A1 L504	9170-0894	0	1	CORE-SHLD BEAD	06337	56-590-65/4A6
A1 L505	9170-0894	0	1	CORE-SHLD BEAD	06337	56-590-65/4A6
A1 L506*	9170-0894	0	1	CORE-SHLD BEAD	06337	56-590-65/4A6
A1 L507*	9170-0894	0	1	CORE-SHLD BEAD	06337	56-590-65/4A6
A1 L508*	9170-0029	3	1	CORE-SHLD BEAD	04822	57-3452
A1 L509*	9170-0029	3	1	CORE-SHLD BEAD	04822	57-3452
A1 L510*	9170-0029	3	1	CORE-SHLD BEAD	04822	57-3452
A1 L511*	9170-0029	3	1	CORE-SHLD BEAD	04822	57-3452
A1 MP1	08116-21106	2	1	HEATSINK	28480	08116-21106
A1 MP2	08112-45401	6	1	PLATE INSULATOR	28480	08112-45401
A1 MP3	08112-45401	6	1	PLATE INSULATOR	28480	08112-45401
A1 MP4	00180-09104	6	1	CLIP GROUND	28480	08116-09104
A1 MP100	08112-04155	1	1	BRACKET-POTI	28480	08112-04155
A1 MP200	1205-0235	0	1	HEAT SINK	02608	2224-B
A1 MP201	1205-0235	0	1	HEAT SINK	02608	2224-B
A1 MP500	08116-04152	2	1	XSTR-HEATSINK	28480	08116-04152
A1 MP501	1205-0662	7	1	HEAT SINK	02123	260-4TH5B-SPECIAL THREAD
A1 Q1	1854-0368	5	1	XSTR NPN 2N5191	02037	2N5191
A1 Q2	1854-0637	1	1	XSTR NPN 2N2219A	02037	2N2219A
A1 Q3	1854-0368	5	1	XSTR NPN 2N5191	02037	2N5191
A1 Q4	1854-0637	1	1	XSTR NPN 2N2219A	02037	2N2219A
A1 Q5	1853-0314	9	1	XSTR PNP 2N2905A	02037	2N2905A
A1 Q6	1853-0212	6	1	XSTR PNP 2N5194	02037	2N5194
A1 Q7	1854-1028	6	1	XSTR NPN SI	02037	2N3904
A1 Q8	1853-0563	0	1	XSTR PNP SI	02037	2N3906(SEL)
A1 Q100	1854-1028	6	1	XSTR NPN SI	02037	2N3904
A1 Q101	1853-0563	0	1	XSTR PNP SI	02037	2N3906(SEL)
A1 Q102	1854-1028	6	1	XSTR NPN SI	02037	2N3904

Table A-3.
Standard HP 8116A Main Board Parts List (continued)

Reference	HP Part #	CD	Qty	Description	Manuf'r	Part #
A1 Q200	1853-0563	0	1	XSTR PNP SI	02037	2N3906(SEL)
A1 Q201	1853-0563	0	1	XSTR PNP SI	02037	2N3906(SEL)
A1 Q202	1853-0563	0	1	XSTR PNP SI	02037	2N3906(SEL)
A1 Q203	1853-0354	7	1	XSTR PNP SI	02037	
A1 Q204	1853-0354	7	1	XSTR PNP SI	02037	
A1 Q205	1854-1028	6	1	XSTR NPN SI	02037	2N3904
A1 Q206	1854-1028	6	1	XSTR NPN SI	02037	2N3904
A1 Q207	1854-1028	6	1	XSTR NPN SI	02037	2N3904
A1 Q208	1854-1028	6	1	XSTR NPN SI	02037	2N3904
A1 Q209	1854-1028	6	1	XSTR NPN SI	02037	2N3904
A1 Q210	1854-1028	6	1	XSTR NPN SI	02037	2N3904
A1 Q211	1853-0563	0	1	XSTR PNP SI	02037	2N3906(SEL)
A1 Q212	1853-0563	0	1	XSTR PNP SI	02037	2N3906(SEL)
A1 Q213	1853-0563	0	1	XSTR PNP SI	02037	2N3906(SEL)
A1 Q214	1853-0563	0	1	XSTR PNP SI	02037	2N3906(SEL)
A1 Q215	1853-0563	0	1	XSTR PNP SI	02037	2N3906(SEL)
A1 Q216	1853-0563	0	1	XSTR PNP SI	02037	2N3906(SEL)
A1 Q220	1854-1028	6	1	XSTR NPN SI	02037	2N3904
A1 Q260	1854-1139	0	1	XSTR NPN SI	02037	MPSH10
A1 Q261	1854-1139	0	1	XSTR NPN SI	02037	MPSH10
A1 Q262	1853-0357	0	1	XSTR PNP SI	02037	
A1 Q263	1853-0357	0	1	XSTR PNP SI	02037	
A1 Q300	1854-1028	6	1	XSTR NPN SI	02037	2N3904
A1 Q301	1854-1028	6	1	XSTR NPN SI	02037	2N3904
A1 Q302	1854-1028	6	1	XSTR NPN SI	02037	2N3904
A1 Q303	1854-1028	6	1	XSTR NPN SI	02037	2N3904
A1 Q401	1853-0589	0	1	XSTR-DUAL PNP	02037	MD4260
A1 Q402	1853-0218	2	1	XSTR PNP SI	03406	NS65098
A1 Q403	1853-0563	0	1	XSTR PNP SI	02037	2N3906(SEL)
A1 Q430	1853-0563	0	1	XSTR PNP SI	02037	2N3906(SEL)

Table A-3.
Standard HP 8116A Main Board Parts List (continued)

Reference	HP Part #	CD	Qty	Description	Manufr	Part #
A1 Q431	1854-0392	5	1	XSTR NPN SI	02037	2N5088
A1 Q432	1853-0569	6	1	XSTR PNP SI	02037	
A1 Q433	1854-1028	6	1	XSTR NPN SI	02037	2N3904
A1 Q501	1854-0809	9	1	XSTR NPN 2N2369A	02037	2N2369A
A1 Q502	1853-0405	9	1	XSTR PNP SI	02037	2N4209
A1 Q503	1854-0354	9	1	XSTR NPN SI	02037	
A1 Q504	1853-0357	0	1	XSTR PNP SI	02037	
A1 Q505	1853-0625	5	1	XSTR PNP SI	02037	MRF545
A1 Q506	1854-1114	1	1	XSTR NPN SI	02037	MRF544
A1 Q507	1854-0477	7	1	XSTR NPN 2N2222A	02037	2N2222A
A1 Q508	1854-0784	9	1	XSTR NPN 2N3866A	02037	2N3866A
A1 Q509	1853-0312	7	1	XSTR PNP SI	02037	
A1 Q510	1854-0637	1	1	XSTR NPN 2N2219A	02037	2N2219A
A1 Q511	1853-0314	9	1	XSTR PNP 2N2905A	02037	2N2905A
A1 Q512	1854-0637	1	1	XSTR NPN 2N2219A	02037	2N2219A
A1 Q513	1853-0314	9	1	XSTR PNP 2N2905A	02037	2N2905A
A1 Q514	1854-1028	6	1	XSTR NPN SI	02037	2N3904
A1 Q515	1853-0563	0	1	XSTR PNP SI	02037	2N3906(SEL)
A1 Q590	1854-1028	6	1	XSTR NPN SI	02037	2N3904
A1 Q591	1854-1028	6	1	XSTR NPN SI	02037	2N3904
A1 R1	0764-0013	5	1	RES 56 5% 2W MO	02499	GS-3
A1 R2	0812-0111	7	1	RES .05 3% 3W	05524	RS-2B
A1 R3	0698-4508	0	1	RES 78.7K 1%	05524	CMF-55-1, T-1
A1 R4	0698-0085	0	1	RES 2.61K 1%	05524	CMF-55-1, T-1
A1 R5	0812-0045	6	1	RES .15 5% 3W	05524	CW-2B-39
A1 R6	0757-0460	1	1	RES 61.9K 1%	05524	CMF-55-1, T-1
A1 R7	0698-0085	0	1	RES 2.61K 1%	05524	CMF-55-1, T-1
A1 R8	0698-0085	0	1	RES 2.61K 1%	05524	CMF-55-1, T-1
A1 R9	0757-0464	5	1	RES 90.9K 1%	05524	CMF-55-1, T-1
A1 R10	0812-0111	7	1	RES .05 3% 3W	05524	RS-2B

Table A-3.
Standard HP 8116A Main Board Parts List (continued)

Reference	HP Part #	CD	Qty	Description	Manuf'r	Part #
A1 R11	0698-4460	3	1	RES 649 1% .125W	05524	CMF-55-1, T-1
A1 R12	2100-3211	7	1	RES-TRMR 1K 10%	03744	3386P-Y46-102
A1 R13	0757-0401	0	1	RES 100 1% .125W	05524	CMF-55-1, T-1
A1 R14	0698-6320	8	1	RES 5K .1% .125W	05524	CMF-55-1, T-9
A1 R15	0698-8863	8	1	RES 5.2K .1%	05524	CMF-55-1
A1 R16	0698-3442	9	1	RES 237 1% .125W	05524	CMF-55-1, T-1
A1 R17	0757-0434	9	1	RES 3.65K 1%	05524	CMF-55-1, T-1
A1 R18	2100-3211	7	1	RES-TRMR 1K 10%	03744	3386P-Y46-102
A1 R19	2100-3089	7	1	RES-TRMR 5K 10%	04568	67WR
A1 R21	0698-3442	9	1	RES 237 1% .125W	05524	CMF-55-1, T-1
A1 R22	0698-4421	6	1	RES 249 1% .125W	05524	CMF-55-1, T-1
A1 R24	2100-3089	7	1	RES-TRMR 5K 10%	04568	67WR
A1 R25	2100-0554	5	1	RES-TRMR 500 10%	03744	3386P-Y46-501
A1 R26	0698-4435	2	1	RES 2.49K 1%	05524	CMF-55-1, T-1
A1 R27	0698-4421	6	1	RES 249 1% .125W	05524	CMF-55-1, T-1
A1 R28	1810-0037	3	1	NETWORK-RES DIP	02483	761-3-R1K
A1 R30	0757-0449	6	1	RES 20K 1% .125W	05524	CMF-55-1, T-1
A1 R31	0757-0449	6	1	RES 20K 1% .125W	05524	CMF-55-1, T-1
A1 R32	0757-0449	6	1	RES 20K 1% .125W	05524	CMF-55-1, T-1
A1 R33	0757-0449	6	1	RES 20K 1% .125W	05524	CMF-55-1, T-1
A1 R34	0698-3454	3	1	RES 215K 1%	05524	CMF-55-1, T-1
A1 R35	0811-2455	4	1	RES 2 1% 3W PWI	05524	RS-2B
A1 R36	0811-2455	4	1	RES 2 1% 3W PWI	05524	RS-2B
A1 R37	0757-0438	3	1	RES 5.11K 1%	05524	CMF-55-1, T-1
A1 R38	0698-3454	3	1	RES 215K 1%	05524	CMF-55-1, T-1
A1 R39	0698-3452	1	1	RES 147K 1%	05524	CMF-55-1, T-1
A1 R40	0698-3160	8	1	RES 31.6K 1%	05524	CMF-55-1, T-1
A1 R41	0757-0438	3	1	RES 5.11K 1%	05524	CMF-55-1, T-1
A1 R42	0757-0438	3	1	RES 5.11K 1%	05524	CMF-55-1, T-1
A1 R43	0698-3160	8	1	RES 31.6K 1%	05524	CMF-55-1, T-1

Table A-3.
Standard HP 8116A Main Board Parts List (continued)

Reference	HP Part #	CD	Qty	Description	Manufr	Part #
A1 R44	0698-3160	8	1	RES 31.6K 1%	05524	CMF-55-1, T-1
A1 R45	0757-0465	6	1	RES 100K 1%	05524	CMF-55-1, T-1
A1 R46	0757-0442	9	1	RES 10K 1% .125W	05524	CMF-55-1, T-1
A1 R47	0698-3452	1	1	RES 147K 1%	05524	CMF-55-1, T-1
A1 R48	0757-0465	6	1	RES 100K 1%	05524	CMF-55-1, T-1
A1 R100	0698-3540	8	1	RES 15.4K 1%	05524	CMF-55-1, T-1
A1 R101	0757-0449	6	1	RES 20K 1% .125W	05524	CMF-55-1, T-1
A1 R102	0757-0449	6	1	RES 20K 1% .125W	05524	CMF-55-1, T-1
A1 R103	0757-0449	6	1	RES 20K 1% .125W	05524	CMF-55-1, T-1
A1 R104	0698-3154	0	1	RES 4.22K 1%	05524	CMF-55-1, T-1
A1 R105	0757-0410	1	1	RES 301 1% .125W	05524	CMF-55-1, T-1
A1 R106	2100-3976	1	1	RES-V SS 10K	02582	392
A1 R107	0698-3359	7	1	RES 12.7K 1%	05524	CMF-55-1, T-1
A1 R108	0698-4497	6	1	RES 48.7K 1%	05524	CMF-55-1, T-1
A1 R109	0698-4435	2	1	RES 2.49K 1%	05524	CMF-55-1, T-1
A1 R110	0757-0401	0	1	RES 100 1% .125W	05524	CMF-55-1, T-1
A1 R111	0698-3178	8	1	RES 487 1% .125W	05524	CMF-55-1, T-1
A1 R112	1810-0203	5	1	NETWORK-RES SIP	02483	750-81
A1 R113	0698-3152	8	1	RES 3.48K 1%	05524	CMF-55-1, T-1
A1 R114	0698-3178	8	1	RES 487 1% .125W	05524	CMF-55-1, T-1
A1 R115	0757-0401	0	1	RES 100 1% .125W	05524	CMF-55-1, T-1
A1 R116	1810-0280	8	1	NETWORK-RES SIP	05524	MSP10A01
A1 R117	1810-0243	3	1	NETWORK-RES DIP	02483	761-3-R6.8K
A1 R118	1810-0279	5	1	NETWORK-RES SIP	05524	MSP10A01
A1 R119	0757-0280	3	1	RES 1K 1% .125W	05524	CMF-55-1, T-1
A1 R120	0757-0420	3	1	RES 750 1% .125W	05524	CMF-55-1, T-1
A1 R121	0757-0439	4	1	RES 6.81K 1%	05524	CMF-55-1, T-1
A1 R122	0757-0410	1	1	RES 301 1% .125W	05524	CMF-55-1, T-1
A1 R123	0698-3444	1	1	RES 316 1% .125W	05524	CMF-55-1, T-1
A1 R124	0698-7214	1	1	RES 121 1% .05W	05524	CMF-50-2

**Table A-3.
Standard HP 8116A Main Board Parts List (continued)**

Reference	HP Part #	CD	Qty	Description	Manuf'r	Part #
A1 R125	0698-3178	8	1	RES 487 1% .125W	05524	CMF-55-1, T-1
A1 R130	2100-3212	8	1	RES-TRMR 200 10%	03744	3386P-Y46-201
A1 R150	1810-0279	5	1	NETWORK-RES SIP	05524	MSP10A01
A1 R151	0757-0442	9	1	RES 10K 1% .125W	05524	CMF-55-1, T-1
A1 R152	0757-0442	9	1	RES 10K 1% .125W	05524	CMF-55-1, T-1
A1 R153	0757-0442	9	1	RES 10K 1% .125W	05524	CMF-55-1, T-1
A1 R154	0757-0200	7	1	RES 5.62K 1%	05524	CMF-55-1, T-1
A1 R155	0698-4514	8	1	RES 105K 1%	05524	CMF-55-1, T-1
A1 R157*	0698-3258	5		RES 5.36K 1%	05524	CMF-55-1, T-1
A1 R158	1810-0279	5	1	NETWORK-RES SIP	05524	MSP10A01
A1 R200	0698-4422	7	1	RES 1.27K 1%	05524	CMF-55-1, T-1
A1 R201	0698-4422	7	1	RES 1.27K 1%	05524	CMF-55-1, T-1
A1 R202	0757-0419	0	1	RES 681 1% .125W	05524	CMF-55-1, T-1
A1 R204	0698-7226	5	1	RES 383 1% .05W	05524	CMF-50-2
A1 R205	0698-7220	9	1	RES 215 1% .05W	05524	CMF-50-2
A1 R206	0698-7216	3	1	RES 147 1% .05W	05524	CMF-50-2
A1 R207	1810-0281	9	1	NETWORK-RES SIP	05524	MSP10A01
A1 R208	1810-0332	1	1	NETWORK-RES SIP	02483	750-81
A1 R209	1810-0206	8	1	NETWORK-RES SIP	02483	750-81
A1 R210	0698-8827	4	1	RES 1M 1% .125W	05524	CMF-55-1
A1 R211	0698-8827	4	1	RES 1M 1% .125W	05524	CMF-55-1
A1 R213	0698-7215	2	1	RES 133 1% .05W	05524	CMF-50-2
A1 R215	0757-0419	0	1	RES 681 1% .125W	05524	CMF-55-1, T-1
A1 R216	0698-4367	9	1	RES 20.5 1%	05524	CMF-55-1, T-1
A1 R217	0698-3433	8	1	RES 28.7 1%	05524	CMF-55-1, T-1
A1 R219*	0757-0440	7		RES 7.5K 1%	05524	CMF-55-1, T-1
A1 R220*	0698-3152	8		RES 3.48K 1%	05524	CMF-55-1, T-1
A1 R221	2100-3252	6	1	RES-TRMR 5K 10%	03744	3386P-Y46-502
A1 R222*	0757-0440	7		RES 7.5K 1%	05524	CMF-55-1, T-1
A1 R223*	0698-3152	8		RES 3.48K 1%	05524	CMF-55-1, T-1

Table A-3.
Standard HP 8116A Main Board Parts List (continued)

Reference	HP Part #	CD	Qty	Description	Manuf'r	Part #
A1 R224	2100-3252	6	1	RES-TRMR 5K 10%	03744	3386P-Y46-502
A1 R225	0698-3439	4	1	RES 178 1% .125W	05524	CMF-55-1, T-1
A1 R226	0757-0278	9	1	RES 1.78K 1%	05524	CMF-55-1, T-1
A1 R227	2100-3211	7	1	RES-TRMR 1K 10%	03744	3386P-Y46-102
A1 R228	0698-8819	4	1	RES 3.83 1%	05524	CMF-55-1
A1 R229	0757-0410	1	1	RES 301 1% .125W	05524	CMF-55-1, T-1
A1 R230	0757-0280	3	1	RES 1K 1% .125W	05524	CMF-55-1, T-1
A1 R231	0757-0420	3	1	RES 750 1% .125W	05524	CMF-55-1, T-1
A1 R232	0698-6324	2	1	RES 187 1% .125W	05524	CMF-55-1, T-1
A1 R233	0757-0410	1	1	RES 301 1% .125W	05524	CMF-55-1, T-1
A1 R234	0757-0410	1	1	RES 301 1% .125W	05524	CMF-55-1, T-1
A1 R235	0698-4073	4	1	RES 1M 10% .125W	01607	BB1051
A1 R236	0698-4073	4	1	RES 1M 10% .125W	01607	BB1051
A1 R237	0698-4073	4	1	RES 1M 10% .125W	01607	BB1051
A1 R238	0698-4073	4	1	RES 1M 10% .125W	01607	BB1051
A1 R239	0698-4073	4	1	RES 1M 10% .125W	01607	BB1051
A1 R240	0698-3155	1	1	RES 4.64K 1%	05524	CMF-55-1, T-1
A1 R241	0757-0280	3	1	RES 1K 1% .125W	05524	CMF-55-1, T-1
A1 R242*	0698-4469	2		RES 1.15K 1%	05524	CMF-55-1, T-1
A1 R243	0757-0274	5	1	RES 1.21K 1%	05524	CMF-55-1, T-1
A1 R244	0698-0083	8	1	RES 1.96K 1%	05524	CMF-55-1, T-1
A1 R245	0757-0405	4	1	RES 162 1% .125W	05524	CMF-55-1, T-1
A1 R246	0698-3446	3	1	RES 383 1% .125W	05524	CMF-55-1, T-1
A1 R260	0698-3178	8	1	RES 487 1% .125W	05524	CMF-55-1, T-1
A1 R261	0698-3442	9	1	RES 237 1% .125W	05524	CMF-55-1, T-1
A1 R262	0757-0419	0	1	RES 681 1% .125W	05524	CMF-55-1, T-1
A1 R263	0698-4421	6	1	RES 249 1% .125W	05524	CMF-55-1, T-1
A1 R264	0757-0499	6	1	RES 27.4 1% .25W	05524	CMF-60-1, T-1
A1 R265	0757-1000	7	1	RES 51.1 1% .5W	05524	CMF-65-2
A1 R266	0757-0389	3	1	RES 33.2 1%	05524	CMF-55-1, T-1

Table A-3.
Standard HP 8116A Main Board Parts List (continued)

Reference	HP Part #	CD	Qty	Description	Manuf'r	Part #
A1 R267	0757-0803	6	1	RES 182 1% .5W	05524	CMF-65-2
A1 R268	0757-0803	6	1	RES 182 1% .5W	05524	CMF-65-2
A1 R269	0757-1094	9	1	RES 1.47K 1%	05524	CMF-55-1, T-1
A1 R270	0698-4460	3	1	RES 649 1% .125W	05524	CMF-55-1, T-1
A1 R271	0698-4404	5	1	RES 105 1% .125W	05524	CMF-55-1, T-1
A1 R272	0698-3433	8	1	RES 28.7 1%	05524	CMF-55-1, T-1
A1 R273	0757-0280	3	1	RES 1K 1% .125W	05524	CMF-55-1, T-1
A1 R274	0757-0407	6	1	RES 200 1% .125W	05524	CMF-55-1, T-1
A1 R275	0698-4416	9	1	RES 169 1% .125W	05524	CMF-55-1, T-1
A1 R276	0757-0419	0	1	RES 681 1% .125W	05524	CMF-55-1, T-1
A1 R277	0757-0419	0	1	RES 681 1% .125W	05524	CMF-55-1, T-1
A1 R300	0757-0401	0	1	RES 100 1% .125W	05524	CMF-55-1, T-1
A1 R301	0698-3178	8	1	RES 487 1% .125W	05524	CMF-55-1, T-1
A1 R302	0698-3178	8	1	RES 487 1% .125W	05524	CMF-55-1, T-1
A1 R303	0698-3228	9	1	RES 49.9K 1%	05524	CMF-55-1, T-1
A1 R304	2100-3210	6	1	RES-TRMR 10K 10%	03744	3386P-Y46-103
A1 R305	0757-0401	0	1	RES 100 1% .125W	05524	CMF-55-1, T-1
A1 R306	0757-0460	1	1	RES 61.9K 1%	05524	CMF-55-1, T-1
A1 R307	0698-4486	3	1	RES 24.9K 1%	05524	CMF-55-1, T-1
A1 R308	0757-0280	3	1	RES 1K 1% .125W	05524	CMF-55-1, T-1
A1 R309*	0757-0401	0		RES 100 1% .125W	05524	CMF-55-1, T-1
A1 R310	0698-3441	8	1	RES 215 1% .125W	05524	CMF-55-1, T-1
A1 R311	0698-3160	8	1	RES 31.6K 1%	05524	CMF-55-1, T-1
A1 R400	0698-3498	5	1	RES 8.66K 1%	05524	CMF-55-1, T-1
A1 R401	2100-3253	7	1	RES-TRMR 50K 10%	03744	3386P-Y46-503
A1 R402	2100-3253	7	1	RES-TRMR 50K 10%	03744	3386P-Y46-503
A1 R403	2100-3253	7	1	RES-TRMR 50K 10%	03744	3386P-Y46-503
A1 R404	0698-4446	5	1	RES 267 1% .125W	05524	CMF-55-1, T-1
A1 R405	0757-0426	9	1	RES 1.3K 1%	05524	CMF-55-1, T-1
A1 R406	0757-0421	4	1	RES 825 1% .125W	05524	CMF-55-1, T-1

Table A-3.
Standard HP 8116A Main Board Parts List (continued)

Reference	HP Part #	CD	Qty	Description	Manuf'r	Part #
A1 R407	2100-3091	1	1	RES-TRMR 2K 10%	04568	67WR
A1 R408	0698-4447	6	1	RES 280 1% .125W	05524	CMF-55-1, T-1
A1 R409	2100-0558	9	1	RES-TRMR 20K 10%	03744	3386P-Y46-203
A1 R410	2100-3211	7	1	RES-TRMR 1K 10%	03744	3386P-Y46-102
A1 R411	0757-0278	9	1	RES 1.78K 1%	05524	CMF-55-1, T-1
A1 R412	0698-7220	9	1	RES 215 1% .05W	05524	CMF-50-2
A1 R413	2100-0558	9	1	RES-TRMR 20K 10%	03744	3386P-Y46-203
A1 R414	2100-0558	9	1	RES-TRMR 20K 10%	03744	3386P-Y46-203
A1 R415	0698-7205	0	1	RES 51.1 1% .05W	05524	CMF-50-2
A1 R416	2100-0558	9	1	RES-TRMR 20K 10%	03744	3386P-Y46-203
A1 R417	2100-0558	9	1	RES-TRMR 20K 10%	03744	3386P-Y46-203
A1 R418	2100-0558	9	1	RES-TRMR 20K 10%	03744	3386P-Y46-203
A1 R419	0698-3428	1	1	RES 14.7 1%	05524	CMF-55-1, T-1
A1 R420	0698-3428	1	1	RES 14.7 1%	05524	CMF-55-1, T-1
A1 R421	0698-7221	0	1	RES 237 1% .05W	05524	CMF-50-2
A1 R422	0757-0442	9	1	RES 10K 1% .125W	05524	CMF-55-1, T-1
A1 R423*	0698-4469	2		RES 1.15K 1%	05524	CMF-55-1, T-1
A1 R424	0757-0280	3	1	RES 1K 1% .125W	05524	CMF-55-1, T-1
A1 R425	2100-3296	8	1	RES-TRMR 1K 10%	04568	67WR
A1 R426	0757-0280	3	1	RES 1K 1% .125W	05524	CMF-55-1, T-1
A1 R427*	0698-4469	2		RES 1.15K 1%	05524	CMF-55-1, T-1
A1 R428*	0698-7236	7		RES 1K 1% .05W	05524	CMF-50-2
A1 R430	0698-4444	3	1	RES 4.87K 1%	05524	CMF-55-1, T-1
A1 R431	0698-4444	3	1	RES 4.87K 1%	05524	CMF-55-1, T-1
A1 R432	0757-0273	4	1	RES 3.01K 1%	05524	CMF-55-1, T-1
A1 R433	0698-4444	3	1	RES 4.87K 1%	05524	CMF-55-1, T-1
A1 R434	0698-4444	3	1	RES 4.87K 1%	05524	CMF-55-1, T-1
A1 R435	0698-3446	3	1	RES 383 1% .125W	05524	CMF-55-1, T-1
A1 R436	0698-3226	7	1	RES 6.49K 1%	05524	CMF-55-1, T-1
A1 R437	0698-4425	0	1	RES 1.54K 1%	05524	CMF-55-1, T-1

Table A-3.
Standard HP 8116A Main Board Parts List (continued)

Reference	HP Part #	CD	Qty	Description	Manuf'r	Part #
A1 R438	0698-3155	1	1	RES 4.64K 1%	05524	CMF-55-1, T-1
A1 R439	0757-0444	1		RES 12.1K 1%	05524	CMF-55-1, T-1
A1 R440	0757-0419	0	1	RES 681 1% .125W	05524	CMF-55-1, T-1
A1 R441*	0698-3432	7	1	RES 26.1 1% .125W	00746	
A1 R445	2100-3097	7	1	RES-TRMR 100K	04568	67WR
A1 R446	0757-0449	6	1	RES 20K 1% .125W	05524	CMF-55-1, T-1
A1 R447	0698-8958	2	1	RES 511K 1%	01074	H8
A1 R449	0698-3450	9	1	RES 42.2K 1%	05524	CMF-55-1, T-1
A1 R450	2100-3214	0	1	RES-TRMR 100K	03744	3386P-Y46-104
A1 R451	0698-4486	3	1	RES 24.9K 1%	05524	CMF-55-1, T-1
A1 R452	0757-0460	1	1	RES 61.9K 1%	05524	CMF-55-1, T-1
A1 R453	0698-4498	7	1	RES 53.6K 1%	05524	CMF-55-1, T-1
A1 R454	0757-0276	7	1	RES 61.9 1%	05524	CMF-55-1, T-1
A1 R501	0698-7196	8	1	RES 21.5 1% .05W	05524	CMF-50-2
A1 R502	0757-0385	9	1	RES 22.1 1%	05524	CMF-55-1, T-1
A1 R503	0698-4392	0	1	RES 71.5 1%	05524	CMF-55-1, T-1
A1 R504	0757-0294	9	1	RES 17.8 1%	05524	CMF-55-1, T-1
A1 R505	0757-0346	2	1	RES 10 1% .125W	05524	CMF-55-1, T-1
A1 R506	0698-3440	7	1	RES 196 1% .125W	05524	CMF-55-1, T-1
A1 R507	0699-0644	9	1	RES 7.87 1%	01074	H8
A1 R508	0757-0462	3	1	RES 75K 1% .125W	05524	CMF-55-1, T-1
A1 R509	0698-4421	6	1	RES 249 1% .125W	05524	CMF-55-1, T-1
A1 R510	0757-0440	7	1	RES 7.5K 1%	05524	CMF-55-1, T-1
A1 R511	0698-3359	7	1	RES 12.7K 1%	05524	CMF-55-1, T-1
A1 R512	0698-3359	7	1	RES 12.7K 1%	05524	CMF-55-1, T-1
A1 R513	0698-3498	5	1	RES 8.66K 1%	05524	CMF-55-1, T-1
A1 R514	0698-4460	3	1	RES 649 1% .125W	05524	CMF-55-1, T-1
A1 R515	2100-0568	1	1	RES-TRMR 100 10%	03744	3386P-Y46-101
A1 R516	0757-0443	0	1	RES 11K 1% .125W	05524	CMF-55-1, T-1
A1 R517	0757-0443	0	1	RES 11K 1% .125W	05524	CMF-55-1, T-1
A1 R518	0698-4386	2	1	RES 59 1% .125W	05524	CMF-55-1, T-1

Table A-3.
Standard HP 8116A Main Board Parts List (continued)

Reference	HP Part #	CD	Qty	Description	Manuf'r	Part #
A1 R519	0698-4386	2	1	RES 59 1% .125W	05524	CMF-55-1, T-1
A1 R520	0757-0280	3	1	RES 1K 1% .125W	05524	CMF-55-1, T-1
A1 R521	0757-0280	3	1	RES 1K 1% .125W	05524	CMF-55-1, T-1
A1 R522	0757-0280	3	1	RES 1K 1% .125W	05524	CMF-55-1, T-1
A1 R523	0757-0280	3	1	RES 1K 1% .125W	05524	CMF-55-1, T-1
A1 R524	0757-0401	0	1	RES 100 1% .125W	05524	CMF-55-1, T-1
A1 R525	0757-0283	6	1	RES 2K 1% .125W	05524	CMF-55-1, T-1
A1 R526	0757-0283	6	1	RES 2K 1% .125W	05524	CMF-55-1, T-1
A1 R527	0757-0401	0	1	RES 100 1% .125W	05524	CMF-55-1, T-1
A1 R528	0698-3495	2	1	RES 866 1% .125W	05524	CMF-55-1, T-1
A1 R529	0698-3495	2	1	RES 866 1% .125W	05524	CMF-55-1, T-1
A1 R530	0757-1022	3	1	RES 1.78K 1%	05524	CMF-60-1, T-1
A1 R531	0757-1022	3	1	RES 1.78K 1%	05524	CMF-60-1, T-1
A1 R532	0757-0751	3	1	RES 7.5K 1% .25W	05524	CMF-60-1, T-1
A1 R533	0698-3429	2	1	RES 19.6 1%	05524	CMF-55-1, T-1
A1 R534	0698-3429	2	1	RES 19.6 1%	05524	CMF-55-1, T-1
A1 R535	2100-3211	7	1	RES-TRMR 1K 10%	03744	3386P-Y46-102
A1 R536	0698-7221	0	1	RES 237 1% .05W	05524	CMF-50-2
A1 R537	0698-3429	2	1	RES 19.6 1%	05524	CMF-55-1, T-1
A1 R538	0698-3429	2	1	RES 19.6 1%	05524	CMF-55-1, T-1
A1 R539	0698-8820	7	1	RES 4.64 1%	05524	CMF-55-1
A1 R540	0698-8820	7	1	RES 4.64 1%	05524	CMF-55-1
A1 R541	0698-3495	2	1	RES 866 1% .125W	05524	CMF-55-1, T-1
A1 R542	0698-3495	2	1	RES 866 1% .125W	05524	CMF-55-1, T-1
A1 R543	0757-0346	2	1	RES 10 1% .125W	05524	CMF-55-1, T-1
A1 R544	0757-0346	2	1	RES 10 1% .125W	05524	CMF-55-1, T-1
A1 R545	0757-0346	2	1	RES 10 1% .125W	05524	CMF-55-1, T-1
A1 R546	0757-0346	2	1	RES 10 1% .125W	05524	CMF-55-1, T-1
A1 R547	0766-0025	3	1	RES 101 2% 3W MO	12482	FP-3
A1 R548	0766-0025	3	1	RES 101 2% 3W MO	12482	FP-3

**Table A-3.
Standard HP 8116A Main Board Parts List (continued)**

Reference	HP Part #	CD	Qty	Description	Manuf'r	Part #
A1 R549	0757-0818	3	1	RES 825 1% .5W	05524	CMF-65-2
A1 R550	0698-4864	1	1	RES 499 1% .5W	05524	CMF-65-2
A1 R551	0757-1001	8	1	RES 56.2 1% .5W	05524	CMF-65-2
A1 R552	0757-0280	3	1	RES 1K 1% .125W	05524	CMF-55-1, T-1
A1 R553	0698-8369	9	1	RES 2.7 5% .125W	01607	BB27G5
A1 R554	0698-4367	9	1	RES 20.5 1%	05524	CMF-55-1, T-1
A1 R555	0698-4367	9	1	RES 20.5 1%	05524	CMF-55-1, T-1
A1 R556	0698-7195	7	1	RES 19.6 1% .05W	05524	CMF-50-2
A1 R558*	0698-7209	4	1	RES 75 1% .05W T	00746	CRB20
A1 R559	0757-0399	5	1	RES 82.5 1%	05524	CMF-55-1, T-1
A1 R560	0757-0399	5	1	RES 82.5 1%	05524	CMF-55-1, T-1
A1 R561*	0757-0279	0	1	RES 3.16K 1% 0.125W	00746	
A1 R590	0757-0460	1	1	RES 61.9K 1%	05524	CMF-55-1, T-1
A1 R591	0698-3226	7	1	RES 6.49K 1%	05524	CMF-55-1, T-1
A1 R592	0757-0442	9	1	RES 10K 1% .125W	05524	CMF-55-1, T-1
A1 R593	0757-0280	3	1	RES 1K 1% .125W	05524	CMF-55-1, T-1
A1 R594	0757-0280	3	1	RES 1K 1% .125W	05524	CMF-55-1, T-1
A1 S1	3101-2956	8	1	SW-PB DPDT	05912	104-02-01003
A1 TP1	0360-2264	6	1	TERM.-TEST POINT	10358	1095D
A1 TP2	0360-2264	6	1	TERM.-TEST POINT	10358	1095D
A1 TP3	0360-2264	6	1	TERM.-TEST POINT	10358	1095D
A1 TP4	0360-2264	6	1	TERM.-TEST POINT	10358	1095D
A1 U1	1826-0315	3	1	IC 348	03406	LM348N
A1 U2	1826-0315	3	1	IC 348	03406	LM348N
A1 U3	1826-0393	7	1	IC LM317T	03406	LM317T
A1 U4	1826-0527	9	1	IC LM337T	03406	LM337T
A1 U5	1826-0393	7	1	IC LM317T	03406	LM317T
A1 U6	1826-0527	9	1	IC LM337T	03406	LM337T
A1 U7	1826-0315	3	1	IC 348	03406	LM348N
A1 U100	1820-0810	1	1	IC-MC10116P	02037	MC10116P
A1 U101	1826-0346	0	1	IC 358	03406	LM358N
A1 U102	1820-0802	1	1	IC-MC10102P	02037	MC10102P

Table A-3.
Standard HP 8116A Main Board Parts List (continued)

Reference	HP Part #	CD	Qty	Description	Manuf'r	Part #
A1 U103	1820-1730	6	1	IC-SN74LS273N	01698	SN74LS273N
A1 U104	1820-1359	5	1	IC-MC10174P	02037	MC10174P
A1 U110	1820-1216	3	1	IC-SN74LS138N	01698	SN74LS138N
A1 U150	1820-1730	6	1	IC-SN74LS273N	01698	SN74LS273N
A1 U151	1826-0207	2	1	IC 318	03406	LM318N
A1 U152	1820-1546	2	1	ANLG MUXR	02037	MC14052BCL
A1 U200	1826-0600	9	1	IC 074A	01698	TL074ACN
A1 U201	1826-0955	7	1	IC 1DB6	01876	1DB6
A1 U202	1826-0111	7	1	IC 1458	03799	CA1458T
A1 U203	1820-1225	4	1	IC-MC10231P	02037	MC10231P
A1 U204	1826-0501	9	1	ANLG MUXR	02037	MC14053BCP
A1 U205	1820-1546	2	1	ANLG MUXR	02037	MC14052BCL
A1 U210	1820-1997	7	1	IC-SN74LS374N	03406	DM74LS374N
A1 U300	1826-0984	2	1	IC 1DD6	01876	1DD6-3901
A1 U301	1820-1212	9	1	IC-SN74LS112AN	01698	SN74LS112AN
A1 U302	1820-1491	6	1	IC-SN74LS367AN	01698	SN74LS367AN
A1 U400	1820-1546	2	1	ANLG MUXR	02037	MC14052BCL
A1 U401	1826-0923	9	1	IC 1DC7	01876	
A1 U501	1826-0635	0	1	IC OP-07C	02180	OP-07CP
A1 U502	1826-0635	0	1	IC OP-07C	02180	OP-07CP
A1 U503	1820-1997	7	1	IC-SN74LS374N	03406	DM74LS374N
A1 VR1	1902-0680	7	1	DIO-ZNR 1N827	02037	1N827
A1 VR2	1902-0961	7	1	DIO-ZNR 13V 5%	02037	
A1 VR3	1902-0961	7	1	DIO-ZNR 13V 5%	02037	
A1 VR200	1902-0680	7	1	DIO-ZNR 1N827	02037	1N827
A1 VR501	1902-3182	0	1	DIO-ZNR 12.1V 5%	02037	
A1 VR502	1902-3182	0	1	DIO-ZNR 12.1V 5%	02037	
A1 VR504	1902-1340	8	1	DIO-ZNR 1N5355B	02037	1N5355B
A1 VR505	1902-1340	8	1	DIO-ZNR 1N5355B	02037	1N5355B
A1 W2	8159-0005	0	1	RES 0 CWM	01339	L-2007-1

**Table A-3.
Standard HP 8116A Main Board Parts List (continued)**

Reference	HP Part #	CD	Qty	Description	Manuf'r	Part #
A1 W3	8159-0005	0	1	RES 0 CWM	01339	L-2007-1
A1 W4	8159-0005	0	1	RES 0 CWM	01339	L-2007-1
A1 W5	8159-0005	0	1	RES 0 CWM	01339	L-2007-1
A1 W7	5180-2401	6	1		28480	5180-2401
A1 W8	08116-61605	0	1		28480	08116-61605
A1 W9	08116-61607	2	1		28480	08116-61607
A1 W10	08116-61608	3	1		28480	08116-61608
A1 W11	08116-61609	4	1		28480	08116-61609
A1 W15	8159-0005	0	1	RES 0 CWM	01339	L-2007-1
A1 W16	8159-0005	0	1	RES 0 CWM	01339	L-2007-1

Control Board

Table A-4. Standard HP 8116A Control Board Parts List

Reference	HP Part #	CD	Qty	Description	Manuf'r	Part #
A2	08116-66522	0	1	BD AY-CONTROL	28480	08116-66522
A2 C1	0160-3839	9	1	CAP 2.2uF 40 V	05992	23122550
A2 C2	0160-3878	6	1	CAP 1000pF 100 V	02010	SR201C102MAAH
A2 C4	0180-2856	0	1	CAP 47uF 25 V	04200	510D058
A2 C5	0160-5746	1	1	CAP 0.1uF 50 V	06121	B37987-T5104-M11
A2 C7	0160-4386	3	1	CAP 33pF 200 V	09939	RPE121-105C0G330J200V
A2 C8	0160-4386	3	1	CAP 33pF 200 V	09939	RPE121-105C0G330J200V
A2 C9	0160-3879	7	1	CAP 0.01uF 100 V	02010	SR201C103MAAH
A2 C10	0180-2856	0	1	CAP 47uF 25 V	04200	510D058
A2 C11	0180-2856	0	1	CAP 47uF 25 V	04200	510D058
A2 C12	0160-3879	7	1	CAP 0.01uF 100 V	02010	SR201C103MAAH
A2 C14	0160-3879	7	1	CAP 0.01uF 100 V	02010	SR201C103MAAH
A2 C15	0160-3718	3	1	CAP 0.047uF 250	05992	23547350
A2 C16	0180-2856	0	1	CAP 47uF 25 V	04200	510D058
A2 C17	0160-5746	1	1	CAP 0.1uF 50 V	06121	B37987-T5104-M11
A2 C18	0160-5746	1	1	CAP 0.1uF 50 V	06121	B37987-T5104-M11
A2 C19	0160-5746	1	1	CAP 0.1uF 50 V	06121	B37987-T5104-M11
A2 C23	0160-5746	1	1	CAP 0.1uF 50 V	06121	B37987-T5104-M11
A2 C26	0160-5746	1	1	CAP 0.1uF 50 V	06121	B37987-T5104-M11
A2 C29	0160-5746	1	1	CAP 0.1uF 50 V	06121	B37987-T5104-M11
A2 CR7	1901-0535	9	1	DIO- SCHOTTKY SM	02062	50825511
A2 CR8	1901-0535	9	1	DIO- SCHOTTKY SM	02062	50825511
A2 CR9	1901-0535	9	1	DIO- SCHOTTKY SM	02062	50825511
A2 CR10	1901-0535	9	1	DIO- SCHOTTKY SM	02062	50825511
A2 CR11	1901-0535	9	1	DIO- SCHOTTKY SM	02062	50825511
A2 CR12	1901-0535	9	1	DIO- SCHOTTKY SM	02062	50825511
A2 CR20	1901-0033	2	1	DIO-GEN PRP	03406	
A2 J4	1251-3119	2	1	CONN-POST-TP-HDR	04726	3428-2002
A2 J5	1251-3119	2	1	CONN-POST-TP-HDR	04726	3428-2002
A2 K1	0490-1412	9	1	RLY-REED 1A	11263	3570.1332.053

Table A-4.
Standard HP 8116A Control Board Parts List (continued)

Reference	HP Part #	CD	Qty	Description	Manuf'r	Part #
A2 K2	0490-1412	9	1	RLY-REED 1A	11263	3570.1332.053
A2 K3	0490-1412	9	1	RLY-REED 1A	11263	3570.1332.053
A2 K4	0490-1412	9	1	RLY-REED 1A	11263	3570.1332.053
A2 Q1	1854-1028	6	1	XSTR NPN SI	02037	2N3904
A2 Q2	1853-0563	0	1	XSTR PNP SI	02037	2N3906(SEL)
A2 Q3	1854-0472	2	1	XSTR NPN SI DARL	02037	MPS-A14
A2 Q4	1854-0472	2	1	XSTR NPN SI DARL	02037	MPS-A14
A2 Q5	1853-0563	0	1	XSTR PNP SI	02037	2N3906(SEL)
A2 R1	0757-0200	7	1	RES 5.62K 1%	05524	CMF-55-1, T-1
A2 R2	2100-0554	5	1	RES-TRMR 500 10%	03744	3386P-Y46-501
A2 R3	0757-0420	3	1	RES 750 1% .125W	05524	CMF-55-1, T-1
A2 R4	2100-3210	6	1	RES-TRMR 10K 10%	03744	3386P-Y46-103
A2 R6	0698-4123	5	1	RES 499 1% .125W	05524	CMF-55-1, T-1
A2 R7	0698-4014	3	1	RES 787 1% .125W	05524	CMF-55-1, T-1
A2 R8	0757-0283	6	1	RES 2K 1% .125W	05524	CMF-55-1, T-1
A2 R9	0757-0449	6	1	RES 20K 1% .125W	05524	CMF-55-1, T-1
A2 R10	0757-0472	5	1	RES 200K 1%	05524	CMF-55-1, T-1
A2 R11	0698-8827	4	1	RES 1M 1% .125W	05524	CMF-55-1
A2 R12	0698-8827	4	1	RES 1M 1% .125W	05524	CMF-55-1
A2 R14	0698-3258	5	1	RES 5.36K 1%	05524	CMF-55-1, T-1
A2 R15	0698-4014	3	1	RES 787 1% .125W	05524	CMF-55-1, T-1
A2 R16	1810-0316	1	1	NETWORK-RES DIP	02483	761-3-R10K
A2 R17	2100-3214	0	1	RES-TRMR 100K	03744	3386P-Y46-104
A2 R18	2100-3214	0	1	RES-TRMR 100K	03744	3386P-Y46-104
A2 R19	0757-0428	1	1	RES 1.62K 1%	05524	CMF-55-1, T-1
A2 R20	0698-3446	3	1	RES 383 1% .125W	05524	CMF-55-1, T-1
A2 R21	1810-0470	8	1	NETWORK-RES DIP	02483	761-3-R2.2K
A2 R22	2100-3214	0	1	RES-TRMR 100K	03744	3386P-Y46-104
A2 R23	0757-0476	9	1	RES 301K 1%	05524	CMF-55-1, T-1
A2 R24	2100-3211	7	1	RES-TRMR 1K 10%	03744	3386P-Y46-102

Table A-4.
Standard HP 8116A Control Board Parts List (continued)

Reference	HP Part #	CD	Qty	Description	Manuf'r	Part #
A2 R25	2100-3214	0	1	RES-TRMR 100K	03744	3386P-Y46-104
A2 R26	0757-0476	9	1	RES 301K 1%	05524	CMF-55-1, T-1
A2 R27	2100-3211	7	1	RES-TRMR 1K 10%	03744	3386P-Y46-102
A2 R28	0698-4442	1	1	RES 4.42K 1%	05524	CMF-55-1, T-1
A2 R29	0757-0417	8	1	RES 562 1% .125W	05524	CMF-55-1, T-1
A2 R31	2100-0567	0	1	RES-TRMR 2K 10%	03744	3386P-Y46-202
A2 R32	2100-0567	0	1	RES-TRMR 2K 10%	03744	3386P-Y46-202
A2 R33	0757-0458	7	1	RES 51.1K 1%	05524	CMF-55-1, T-1
A2 R35	0757-0401	0	1	RES 100 1% .125W	05524	CMF-55-1, T-1
A2 R36	0757-0401	0	1	RES 100 1% .125W	05524	CMF-55-1, T-1
A2 R41	0698-6360	6	1	RES 10K .1%	05524	CMF-55-1, T-9
A2 R42	0698-6360	6	1	RES 10K .1%	05524	CMF-55-1, T-9
A2 R43	2100-3252	6	1	RES-TRMR 5K 10%	03744	3386P-Y46-502
A2 R44	0757-0465	6	1	RES 100K 1%	05524	CMF-55-1, T-1
A2 R45	0698-3155	1	1	RES 4.64K 1%	05524	CMF-55-1, T-1
A2 R46	0757-0465	6	1	RES 100K 1%	05524	CMF-55-1, T-1
A2 R47	0698-4486	3	1	RES 24.9K 1%	05524	CMF-55-1, T-1
A2 R48	0698-4487	4	1	RES 25.5K 1%	05524	CMF-55-1, T-1
A2 R50	1810-0206	8	1	NETWORK-RES SIP	02483	750-81
A2 R51	0757-0280	3	1	RES 1K 1% .125W	05524	CMF-55-1, T-1
A2 R52	0698-3452	1	1	RES 147K 1%	05524	CMF-55-1, T-1
A2 R54	0757-0277	8	1	RES 49.9 1%	05524	CMF-55-1, T-1
A2 R55	0698-3444	1	1	RES 316 1% .125W	05524	CMF-55-1, T-1
A2 R56	0698-6324	2	1	RES 187 1% .125W	05524	CMF-55-1, T-1
A2 R68	0757-0442	9	1	RES 10K 1% .125W	05524	CMF-55-1, T-1
A2 R70	0757-0410	1	1	RES 301 1% .125W	05524	CMF-55-1, T-1
A2 R71	0757-0410	1	1	RES 301 1% .125W	05524	CMF-55-1, T-1
A2 R72	0757-0410	1	1	RES 301 1% .125W	05524	CMF-55-1, T-1
A2 TP2	0360-2264	6	1	TERM.-TEST POINT	10358	1095D
A2 TP3	0360-2264	6	1	TERM.-TEST POINT	10358	1095D

Table A-4.
Standard HP 8116A Control Board Parts List (continued)

Reference	HP Part #	CD	Qty	Description	Manuf'r	Part #
A2 TP4	0360-2264	6	1	TERM.-TEST POINT	10358	1095D
A2 TP5	0360-2264	6	1	TERM.-TEST POINT	10358	1095D
A2 TP6	0360-2264	6	1	TERM.-TEST POINT	10358	1095D
A2 TP7	0360-2264	6	1	TERM.-TEST POINT	10358	1095D
A2 TP8	0360-2264	6	1	TERM.-TEST POINT	10358	1095D
A2 TP9	0360-2264	6	1	TERM.-TEST POINT	10358	1095D
A2 U1	1826-0519	9	1	IC 071	01698	TL071CP
A2 U2	1826-0519	9	1	IC 071	01698	TL071CP
A2 U3	1820-1885	2	1	IC-DM74LS173AN	03406	DM74LS173AN
A2 U4	1826-0276	5	1	IC MC78L05ACP	02037	MC78L05ACP
A2 U5	1826-0600	9	1	IC 074A	01698	TL074ACN
A2 U6	1826-0729	3	1	D/A 10-BIT	03285	AD7522JN
A2 U7	1826-0635	0	1	IC OP-07C	02180	OP-07CP
A2 U8	1826-0639	4	1	D/A 8-BIT	03285	AD7524JN
A2 U9	1826-0635	0	1	IC OP-07C	02180	OP-07CP
A2 U10	1826-0639	4	1	D/A 8-BIT	03285	AD7524JN
A2 U11	1826-0635	0	1	IC OP-07C	02180	OP-07CP
A2 U12	1826-0521	3	1	IC 072	01698	TL072CP
A2 U13	1826-0729	3	1	D/A 10-BIT	03285	AD7522JN
A2 U14	1820-1216	3	1	IC-SN74LS138N	01698	SN74LS138N
A2 U15	1820-1730	6	1	IC-SN74LS273N	01698	SN74LS273N
A2 U16	1826-0501	9	1	ANLG MUXR	02037	MC14053BCP
A2 U17	1826-0501	9	1	ANLG MUXR	02037	MC14053BCP
A2 U19	1820-1199	1	1	IC-SN74LS04N	01698	SN74LS04N
A2 U20	1820-1216	3	1	IC-SN74LS138N	01698	SN74LS138N
A2 U21	1820-1730	6	1	IC-SN74LS273N	01698	SN74LS273N
A2 U22	1820-1730	6	1	IC-SN74LS273N	01698	SN74LS273N
A2 U23	1820-1730	6	1	IC-SN74LS273N	01698	SN74LS273N
A2 U24	1826-0697	4	1	D/A 12-BIT	03285	AD7541JN
A2 U25	1826-0635	0	1	IC OP-07C	02180	OP-07CP

**Table A-4.
Standard HP 8116A Control Board Parts List (continued)**

Reference	HP Part #	CD	Qty	Description	Manuf'r	Part #
A2 U26	1826-0635	0	1	IC OP-07C	02180	OP-07CP
A2 U27	1826-0729	3	1	D/A 10-BIT	03285	AD7522JN
A2 U28	1826-0521	3	1	IC 072	01698	TL072CP
A2 U31	1826-0180	0	1	IC-NE555N	02910	NE555N
A2 U40	1820-1197	9	1	IC-SN74LS00N	01698	SN74LS00N
A2 U43	1820-1730	6	1	IC-SN74LS273N	01698	SN74LS273N
A2 VR1	1902-0786	4	1	DIO-ZNR 1N937	02688	
A2 VR2	1902-0949	1	1	DIO-ZNR 4.3V 5%	02037	
A2 W1	8159-0005	0	1	RES 0 CWM	01339	L-2007-1
A2 W2	8159-0005	0	1	RES 0 CWM	01339	L-2007-1

Microprocessor Board

Table A-5. Standard HP 8116A Microprocessor Board Parts List

Reference	HP Part #	CD	Qty	Description	Manufr	Part #
A3	08116-66535	5	1	BD AY- MICROPRC	28480	08116-66535
A3 BT1	1420-0273	2	1	BAT 3V	08709	BR-2/3AT2P
A3 C1	0160-4493	3	1	CAP 27pF 200 V	06352	FD12C0G2D270J
A3 C2	0160-4493	3	1	CAP 27pF 200 V	06352	FD12C0G2D270J
A3 C3	0160-6623	5	1	CAP 0.1uF 50 V	02010	SA115C104MAAH
A3 C4	0160-6623	5	1	CAP 0.1uF 50 V	02010	SA115C104MAAH
A3 C5	0160-6623	5	1	CAP 0.1uF 50 V	02010	SA115C104MAAH
A3 C6	0180-0229	7	1	CAP 33uF 10 V	04200	150D336X9010B2-DYS
A3 C7	0180-2207	5	1	CAP 100uF 10 V	04200	150D107X9010R2-DYS
A3 C8	0180-0229	7	1	CAP 33uF 10 V	04200	150D336X9010B2-DYS
A3 C9	0160-6623	5	1	CAP 0.1uF 50 V	02010	SA115C104MAAH
A3 C10	0160-6623	5	1	CAP 0.1uF 50 V	02010	SA115C104MAAH
A3 C11	0160-6623	5	1	CAP 0.1uF 50 V	02010	SA115C104MAAH
A3 C12	0160-6623	5	1	CAP 0.1uF 50 V	02010	SA115C104MAAH
A3 C13	0160-6623	5	1	CAP 0.1uF 50 V	02010	SA115C104MAAH
A3 C14	0160-6623	5	1	CAP 0.1uF 50 V	02010	SA115C104MAAH
A3 C15	0160-6623	5	1	CAP 0.1uF 50 V	02010	SA115C104MAAH
A3 C16	0160-6623	5	1	CAP 0.1uF 50 V	02010	SA115C104MAAH
A3 C17	0160-6623	5	1	CAP 0.1uF 50 V	02010	SA115C104MAAH
A3 C18	0160-6623	5	1	CAP 0.1uF 50 V	02010	SA115C104MAAH
A3 C19	0160-6623	5	1	CAP 0.1uF 50 V	02010	SA115C104MAAH
A3 C20	0160-6623	5	1	CAP 0.1uF 50 V	02010	SA115C104MAAH
A3 C21	0160-6623	5	1	CAP 0.1uF 50 V	02010	SA115C104MAAH
A3 C22	0160-6623	5	1	CAP 0.1uF 50 V	02010	SA115C104MAAH
A3 C23	0160-6623	5	1	CAP 0.1uF 50 V	02010	SA115C104MAAH
A3 C24	0160-6623	5	1	CAP 0.1uF 50 V	02010	SA115C104MAAH
A3 C25	0160-6623	5	1	CAP 0.1uF 50 V	02010	SA115C104MAAH
A3 C26	0160-6623	5	1	CAP 0.1uF 50 V	02010	SA115C104MAAH
A3 C27	0160-6623	5	1	CAP 0.1uF 50 V	02010	SA115C104MAAH
A3 C28	0160-6623	5	1	CAP 0.1uF 50 V	02010	SA115C104MAAH

Table A-5.
Standard HP 8116A Microprocessor Board Parts List (continued)

Reference	HP Part #	CD	Qty	Description	Manuf'r	Part #
A3 C29	0160-3877	5	1	CAP 100pF 200 V	02010	SR202C101MAAH
A3 C30	0160-6623	5	1	CAP 0.1uF 50 V	02010	SA115C104MAAH
A3 C31	0160-6623	5	1	CAP 0.1uF 50 V	02010	SA115C104MAAH
A3 C32	0160-6623	5	1	CAP 0.1uF 50 V	02010	SA115C104MAAH
A3 C33	0160-6623	5	1	CAP 0.1uF 50 V	02010	SA115C104MAAH
A3 C34	0160-6623	5	1	CAP 0.1uF 50 V	02010	SA115C104MAAH
A3 C35	0160-6623	5	1	CAP 0.1uF 50 V	02010	SA115C104MAAH
A3 C36	0160-6623	5	1	CAP 0.1uF 50 V	02010	SA115C104MAAH
A3 C37	0160-6623	5	1	CAP 0.1uF 50 V	02010	SA115C104MAAH
A3 CR1	1901-0535	9	1	DIO- SCHOTTKY SM	02062	50825511
A3 CR2	1901-0535	9	1	DIO- SCHOTTKY SM	02062	50825511
A3 CR3	1901-1098	1	1	DIO-1N4150	04486	
A3 CR4	1901-1098	1	1	DIO-1N4150	04486	
A3 CR5	1901-0535	9	1	DIO- SCHOTTKY SM	02062	50825511
A3 CR6	1901-0535	9	1	DIO- SCHOTTKY SM	02062	50825511
A3 J1	1251-8465	1	1	CONN-POST-TP-HDR	04726	3433-5202
A3 J2	1252-1979	0	1	CONN-POST-TP-HDR	04726	3627-5202
A3 J3	1251-3167	0	1	CONN-POST-TP-BDY	03418	09-50-3041
A3 J4	1251-4670	2	1	CONN-POST-TP-HDR	02946	68000-603
A3 J5	1251-4672	4	1	CONN-POST-TP-HDR	02946	68000-610
A3 MP1	1400-0824	7	1	STRAP-CABLE	04225	TY-23M
A3 MP2	1200-0654	7	1	SKT-IC-DIP	02414	DILB40P-308T
A3 MP3	1200-0654	7	1	SKT-IC-DIP	02414	DILB40P-308T
A3 MP4	1200-0861	8	1	SKT-IC-DIP	01380	2-640362-1
A3 Q1	1853-0281	9	1	XSTR PNP 2N2907A	02037	2N2907A
A3 R1	1810-0280	8	1	NETWORK-RES SIP	05524	MSP10A01
A3 R2	0698-8812	7	1	RES 1 1% .125W	05524	CMF-55-1
A3 R3	1810-0277	3	1	NETWORK-RES SIP	05524	MSP10A01
A3 R4	1810-0338	7	1	NETWORK-RES DIP	02483	761-3-R100
A3 R5	1810-0338	7	1	NETWORK-RES DIP	02483	761-3-R100

Table A-5.
Standard HP 8116A Microprocessor Board Parts List (continued)

Reference	HP Part #	CD	Qty	Description	Manufr	Part #
A3 R6	0698-3446	3	1	RES 383 1% .125W	05524	CMF-55-1, T-1
A3 R9	0757-0465	6	1	RES 100K 1%	05524	CMF-55-1, T-1
A3 R10	1810-0037	3	1	NETWORK-RES DIP	02483	761-3-R1K
A3 R11	1810-0503	8	1	NETWORK-RES DIP	02483	761-3-R3.3K
A3 R12	0757-0449	6	1	RES 20K 1% .125W	05524	CMF-55-1, T-1
A3 R13	0757-0442	9	1	RES 10K 1% .125W	05524	CMF-55-1, T-1
A3 R14	1810-0330	9	1	NETWORK-RES DIP	02483	761-3-R470 OHMS
A3 R15	1810-0280	8	1	NETWORK-RES SIP	05524	MSP10A01
A3 R16	1810-0280	8	1	NETWORK-RES SIP	05524	MSP10A01
A3 R17	0698-8812	7	1	RES 1 1% .125W	05524	CMF-55-1
A3 R19	0757-0280	3	1	RES 1K 1% .125W	05524	CMF-55-1, T-1
A3 R20	0757-0280	3	1	RES 1K 1% .125W	05524	CMF-55-1, T-1
A3 R21	0698-3162	0	1	RES 46.4K 1%	05524	CMF-55-1, T-1
A3 R22	0757-0442	9	1	RES 10K 1% .125W	05524	CMF-55-1, T-1
A3 R24	0757-0280	3	1	RES 1K 1% .125W	05524	CMF-55-1, T-1
A3 R25	0757-0442	9	1	RES 10K 1% .125W	05524	CMF-55-1, T-1
A3 R26	0757-0442	9	1	RES 10K 1% .125W	05524	CMF-55-1, T-1
A3 R27	0757-0279	0	1	RES 3.16K 1%	05524	CMF-55-1, T-1
A3 U1	1820-2099	2	1	IC-6802	02037	MC6802P
A3 U2	1820-2075	4	1	IC-SN74LS245N	01698	SN74LS245N
A3 U3	1820-2024	3	1	IC-SN74LS244N	01698	SN74LS244N
A3 U4	1820-2024	3	1	IC-SN74LS244N	01698	SN74LS244N
A3 U10	08116-10020	6	1		28480	08116-10020
A3 U12	1820-1216	3	1	IC-SN74LS138N	01698	SN74LS138N
A3 U13	1820-1216	3	1	IC-SN74LS138N	01698	SN74LS138N
A3 U14	1820-1216	3	1	IC-SN74LS138N	01698	SN74LS138N
A3 U15	1820-1414	3	1	IC-SN74LS12N	01698	SN74LS12N
A3 U16	1820-1997	7	1	IC-SN74LS374N	03406	DM74LS374N
A3 U17	1820-1216	3	1	IC-SN74LS138N	01698	SN74LS138N
A3 U18	1820-1730	6	1	IC-SN74LS273N	01698	SN74LS273N

Table A-5.
Standard HP 8116A Microprocessor Board Parts List
(continued)

Reference	HP Part #	CD	Qty	Description	Manuf'r	Part #
A3 U19	1820-1298	1	1	IC-SN74LS251N	01698	SN74LS251N
A3 U20	1820-1426	7	1	IC-SN74LS145N	01698	SN74LS145N
A3 U21	1820-2024	3	1	IC-SN74LS244N	01698	SN74LS244N
A3 U22	1820-2132	4	1	IC-INTERFACE	03799	ICM7218A
A3 U23	1820-1997	7	1	IC-SN74LS374N	03406	DM74LS374N
A3 U24	1820-1997	7	1	IC-SN74LS374N	03406	DM74LS374N
A3 U25	1820-2075	4	1	IC-SN74LS245N	01698	SN74LS245N
A3 U26	1820-2024	3	1	IC-SN74LS244N	01698	SN74LS244N
A3 U27	1826-0161	7	1	IC 324	03406	LM324N
A3 U29	1858-0053	3	1	XSTR ARY 14P-DIP	02037	
A3 U30	1820-2219	8	1	IC-68488	02037	MC68488P
A3 U31	1820-2058	3	1	IC-INTERFACE	02037	MC3448AL
A3 U32	1820-2058	3	1	IC-INTERFACE	02037	MC3448AL
A3 U33	1820-2058	3	1	IC-INTERFACE	02037	MC3448AL
A3 U34	1820-2058	3	1	IC-INTERFACE	02037	MC3448AL
A3 U35	1820-1416	5	1	IC-SN74LS14N	01698	SN74LS14N
A3 U37	1820-1195	7	1	IC-SN74LS175N	01698	SN74LS175N
A3 U39	1820-1197	9	1	IC-SN74LS00N	01698	SN74LS00N
A3 W1	1258-0141	8	1	JUMPER-REM	02946	65474-004
A3 W2	8159-0005	0	1	RES 0 CWM	01339	L-2007-1
A3 W4	5180-2469	6	1		28480	5180-2469
A3 Y1	0410-0762	2	1	XTAL 4.000 MHZ	07492	

Keyboard

Table A-6. Standard HP 8116A Keyboard Parts List

Reference	HP Part #	CD	Qty	Description	Manuf'r	Part #
A4	08116-66504	8	1	BD AY-KEY	28480	08116-66504
A4 DS1	1990-0665	3	1	LED-LMP	01542	
A4 DS2	1990-0665	3	1	LED-LMP	01542	
A4 DS3	1990-0665	3	1	LED-LMP	01542	
A4 DS4	1990-0665	3	1	LED-LMP	01542	
A4 DS5	1990-0665	3	1	LED-LMP	01542	
A4 DS6	1990-0665	3	1	LED-LMP	01542	
A4 DS7	1990-0665	3	1	LED-LMP	01542	
A4 DS8	1990-0665	3	1	LED-LMP	01542	
A4 DS11	1990-0665	3	1	LED-LMP	01542	
A4 DS12	1990-0665	3	1	LED-LMP	01542	
A4 DS13	1990-0665	3	1	LED-LMP	01542	
A4 DS14	1990-0665	3	1	LED-LMP	01542	
A4 DS15	1990-0665	3	1	LED-LMP	01542	
A4 DS17	1990-0665	3	1	LED-LMP	01542	
A4 DS18	1990-0665	3	1	LED-LMP	01542	
A4 J1	1251-6255	3	1	CONN-POST-TP-SKT	03418	22-14-2204
A4 J2	1251-6255	3	1	CONN-POST-TP-SKT	03418	22-14-2204
A4 MP1	5041-0309	5	1	CAP KEY QUARTER	28480	5041-0309
A4 MP2	5041-0309	5	1	CAP KEY QUARTER	28480	5041-0309
A4 MP7	5041-0726	0	1	KEY CAP LCL	28480	5041-0726
A4 MP8	5041-0285	6	1	KEY CAP PRL-G L	28480	5041-0285
A4 MP9	5041-0285	6	1	KEY CAP PRL-G L	28480	5041-0285
A4 MP10	5041-0285	6	1	KEY CAP PRL-G L	28480	5041-0285
A4 MP11	5041-0276	5	1	KEY CAP PRL-GRA	28480	5041-0276
A4 MP13	5041-0351	7	1	KEY CAP SRF-G L	28480	5041-0351
A4 MP14	5041-0351	7	1	KEY CAP SRF-G L	28480	5041-0351
A4 MP15	5041-0285	6	1	KEY CAP PRL-G L	28480	5041-0285
A4 MP16	5041-0285	6	1	KEY CAP PRL-G L	28480	5041-0285
A4 MP17	5041-0285	6	1	KEY CAP PRL-G L	28480	5041-0285

**Table A-6.
Standard HP 8116A Keyboard Parts List (continued)**

Reference	HP Part #	CD	Qty	Description	Manuf'r	Part #
A4 MP18	5041-0351	7	1	KEY CAP SRF-G L	28480	5041-0351
A4 MP19	5041-0351	7	1	KEY CAP SRF-G L	28480	5041-0351
A4 MP20	5041-0285	6	1	KEY CAP PRL-G L	28480	5041-0285
A4 MP21	5041-0285	6	1	KEY CAP PRL-G L	28480	5041-0285
A4 MP22	5041-0285	6	1	KEY CAP PRL-G L	28480	5041-0285
A4 MP23	5041-0285	6	1	KEY CAP PRL-G L	28480	5041-0285
A4 MP24	5041-0285	6	1	KEY CAP PRL-G L	28480	5041-0285
A4 S1	5060-9436	7	1	SW-PB SPST NO	04486	5560-9436
A4 S3	5060-9436	7	1	SW-PB SPST NO	04486	5560-9436
A4 S7	5060-9436	7	1	SW-PB SPST NO	04486	5560-9436
A4 S8	5060-9436	7	1	SW-PB SPST NO	04486	5560-9436
A4 S9	5060-9436	7	1	SW-PB SPST NO	04486	5560-9436
A4 S10	5060-9436	7	1	SW-PB SPST NO	04486	5560-9436
A4 S11	5060-9436	7	1	SW-PB SPST NO	04486	5560-9436
A4 S13	5060-9436	7	1	SW-PB SPST NO	04486	5560-9436
A4 S14	5060-9436	7	1	SW-PB SPST NO	04486	5560-9436
A4 S15	5060-9436	7	1	SW-PB SPST NO	04486	5560-9436
A4 S16	5060-9436	7	1	SW-PB SPST NO	04486	5560-9436
A4 S17	5060-9436	7	1	SW-PB SPST NO	04486	5560-9436
A4 S18	5060-9436	7	1	SW-PB SPST NO	04486	5560-9436
A4 S19	5060-9436	7	1	SW-PB SPST NO	04486	5560-9436
A4 S20	5060-9436	7	1	SW-PB SPST NO	04486	5560-9436
A4 S21	5060-9436	7	1	SW-PB SPST NO	04486	5560-9436
A4 S22	5060-9436	7	1	SW-PB SPST NO	04486	5560-9436
A4 S23	5060-9436	7	1	SW-PB SPST NO	04486	5560-9436
A4 S24	5060-9436	7	1	SW-PB SPST NO	04486	5560-9436
A4 W1	5180-2403	8	1	CBL RBN 260 MM	28480	5180-2403

Display Board

Table A-7. Standard HP 8116A Display Board Parts List

Reference	HP Part #	CD	Qty	Description	Manuf'r	Part #
A5	08116-66505	9	1	BD AY DISPLAY	28480	08116-66505
A5 DS1	1990-0486	6	1	LED-LMP	01542	HLMP-1301
A5 DS4	1990-0806	4	1	LED-LT BAR	01542	HLMP-2300(SELECTED)
A5 DS5	1990-0774	5	1	LED-LT BAR	01542	HLMP-2600(D,E,F)
A5 DS6	1990-0774	5	1	LED-LT BAR	01542	HLMP-2600(D,E,F)
A5 DS7	1990-0774	5	1	LED-LT BAR	01542	HLMP-2600(D,E,F)
A5 DS15	1990-0486	6	1	LED-LMP	01542	HLMP-1301
A5 DS16	1990-0486	6	1	LED-LMP	01542	HLMP-1301
A5 DS17	1990-0486	6	1	LED-LMP	01542	HLMP-1301
A5 DS18	1990-0806	4	1	LED-LT BAR	01542	HLMP-2300(SELECTED)
A5 DS19	1990-0486	6	1	LED-LMP	01542	HLMP-1301
A5 DS20	1990-0486	6	1	LED-LMP	01542	HLMP-1301
A5 DS21	1990-0486	6	1	LED-LMP	01542	HLMP-1301
A5 DS22	1990-0486	6	1	LED-LMP	01542	HLMP-1301
A5 DS23	1990-0486	6	1	LED-LMP	01542	HLMP-1301
A5 DS24	1990-0486	6	1	LED-LMP	01542	HLMP-1301
A5 DS25	1990-0486	6	1	LED-LMP	01542	HLMP-1301
A5 DS26	1990-0486	6	1	LED-LMP	01542	HLMP-1301
A5 DS27	1990-0486	6	1	LED-LMP	01542	HLMP-1301
A5 DS28	1990-0486	6	1	LED-LMP	01542	HLMP-1301
A5 DS33	1990-0486	6	1	LED-LMP	01542	HLMP-1301
A5 DS34	1990-0486	6	1	LED-LMP	01542	HLMP-1301
A5 DS35	1990-0486	6	1	LED-LMP	01542	HLMP-1301
A5 DS36	1990-0486	6	1	LED-LMP	01542	HLMP-1301
A5 DS37	1990-0486	6	1	LED-LMP	01542	HLMP-1301
A5 DS38	1990-0486	6	1	LED-LMP	01542	HLMP-1301
A5 DS40	1990-0486	6	1	LED-LMP	01542	HLMP-1301
A5 DS41	1990-0846	2	1	DISPLAY-NUM-SEG	01542	
A5 DS42	1990-0846	2		DISPLAY-NUM-SEG	01542	
A5 DS43	1990-0846	2		DISPLAY-NUM-SEG	01542	

**Table A-7.
Standard HP 8116A Display Board Parts List (continued)**

Reference	HP Part #	CD	Qty	Description	Manuf'r	Part #
A5 DS44	1990-0846	2		DISPLAY-NUM-SEG	01542	
A5 J1	1251-7431	9	1	CONN-POST-TP-HDR	08839	5920575
A5 J2	1251-7431	9	1	CONN-POST-TP-HDR	08839	5920575
A5 S1	3101-2529	1	1	SW-RKR DPDT	08360	326.2-01
A5 S2	3101-2529	1	1	SW-RKR DPDT	08360	326.2-01
A5 S3	3101-2529	1	1	SW-RKR DPDT	08360	326.2-01
A5 S4	3101-2529	1	1	SW-RKR DPDT	08360	326.2-01

Option 001 Parts-lists

Master List Option 001

Table A-8. Option 001 HP 8116A Master Parts List

Reference	HP Part #	CD	Qty	Description	Manuf'r	Part #
A0	8116A #0	1	1	LSSS	28480	8116A #001
A0 A2	08116-66532	2	1	BD AY-CONTR.OPT	28480	08116-66532
A0 A4	08116-66514	0	1	BD AY-KEY OPT	28480	08116-66514
A0 A5	08116-66515	1	1	BD AY-DISPL OPT	28480	08116-66515
A0 J5	1250-0083	1	1	CONN-RF BNC	05879	31-221-1020
A0 J6	1250-0083	1		CONN-RF BNC	05879	31-221-1020
A0 J7	1251-2291	9	1	CONN-TEL	11127	
A0 MP3	4040-1973	8	1	LABEL-INFO	05584	
A0 MP45	2950-0001	8	1	NUT-HEX-DBL-CHAM	04604	9002

Note



This master parts-list contains only the *alternative* parts fitted to the Option 001 instrument. Refer to the Standard master parts-list to identify the rest of the instrument's parts.

The parts lists which follow are for the three alternative assemblies fitted to the Option 001 instrument (A2, A4 & A5). They are complete, you do not need to refer to the standard parts lists.

**Control Board
Opt 001**

Table A-9. Option 001 HP 8116A Control Board Parts List

Reference	HP Part #	CD	Qty	Description	Manuf'r	Part #
A2	08116-66532	2	1	BD AY-CONTR.OPT.	28480	08116-66532
A2 C1	0160-3839	9	1	CAP 2.2uF 40 V	05992	23122550
A2 C2	0160-3878	6	1	CAP 1000pF 100 V	02010	SR201C102MAAH
A2 C4	0180-2856	0	1	CAP 47uF 25 V	04200	510D058
A2 C5	0160-5746	1	1	CAP 0.1uF 50 V	06121	B37987-T5104-M11
A2 C7	0160-4386	3	1	CAP 33pF 200 V	09939	RPE121-105C0G330J200V
A2 C8	0160-4386	3	1	CAP 33pF 200 V	09939	RPE121-105C0G330J200V
A2 C9	0160-3879	7	1	CAP 0.01uF 100 V	02010	SR201C103MAAH
A2 C10	0180-2856	0	1	CAP 47uF 25 V	04200	510D058
A2 C11	0180-2856	0	1	CAP 47uF 25 V	04200	510D058
A2 C12	0160-3879	7	1	CAP 0.01uF 100 V	02010	SR201C103MAAH
A2 C13	0160-3877	5	1	CAP 100pF 200 V	02010	SR202C101MAAH
A2 C14	0160-3879	7	1	CAP 0.01uF 100 V	02010	SR201C103MAAH
A2 C15	0160-3718	3	1	CAP 0.047uF 250	05992	23547350
A2 C16	0180-2856	0	1	CAP 47uF 25 V	04200	510D058
A2 C17	0160-5746	1	1	CAP 0.1uF 50 V	06121	B37987-T5104-M11
A2 C18	0160-5746	1	1	CAP 0.1uF 50 V	06121	B37987-T5104-M11
A2 C19	0160-5746	1	1	CAP 0.1uF 50 V	06121	B37987-T5104-M11
A2 C20	0160-3877	5	1	CAP 100pF 200 V	02010	SR202C101MAAH
A2 C21	0160-4386	3	1	CAP 33pF 200 V	09939	RPE121-105C0G330J200V
A2 C22	0160-5746	1	1	CAP 0.1uF 50 V	06121	B37987-T5104-M11
A2 C23	0160-5746	1	1	CAP 0.1uF 50 V	06121	B37987-T5104-M11
A2 C24	0160-5746	1	1	CAP 0.1uF 50 V	06121	B37987-T5104-M11
A2 C25	0160-5746	1	1	CAP 0.1uF 50 V	06121	B37987-T5104-M11
A2 C26	0160-5746	1	1	CAP 0.1uF 50 V	06121	B37987-T5104-M11
A2 C27	0160-5746	1	1	CAP 0.1uF 50 V	06121	B37987-T5104-M11
A2 C28	0160-5746	1	1	CAP 0.1uF 50 V	06121	B37987-T5104-M11
A2 C29	0160-5746	1	1	CAP 0.1uF 50 V	06121	B37987-T5104-M11
A2 C30	0160-5746	1	1	CAP 0.1uF 50 V	06121	B37987-T5104-M11
A2 CR5	1901-1098	1	1	DIO-1N4150	04486	

Table A-9.
Option 001 HP 8116A Control Board Parts List (continued)

Reference	HP Part #	CD	Qty	Description	Manuf'r	Part #
A2 CR6	1901-1098	1	1	DIO-1N4150	04486	
A2 CR7	1901-0535	9	1	DIO- SCHOTTKY SM	02062	50825511
A2 CR8	1901-0535	9	1	DIO- SCHOTTKY SM	02062	50825511
A2 CR9	1901-0535	9	1	DIO- SCHOTTKY SM	02062	50825511
A2 CR10	1901-0535	9	1	DIO- SCHOTTKY SM	02062	50825511
A2 CR11	1901-0535	9	1	DIO- SCHOTTKY SM	02062	50825511
A2 CR12	1901-0535	9	1	DIO- SCHOTTKY SM	02062	50825511
A2 CR13	1901-0535	9	1	DIO- SCHOTTKY SM	02062	50825511
A2 CR14	1901-1098	1	1	DIO-1N4150	04486	
A2 CR15	1901-1098	1	1	DIO-1N4150	04486	
A2 CR16	1901-1098	1	1	DIO-1N4150	04486	
A2 CR17	1901-1098	1	1	DIO-1N4150	04486	
A2 CR20	1901-0033	2	1	DIO-GEN PRP	03406	
A2 F1	2110-0669	4	1	FU-SUBMIN .25A	04703	R251.250T1
A2 F2	2110-0669	4	1	FU-SUBMIN .25A	04703	R251.250T1
A2 J4	1251-3119	2	1	CONN-POST-TP-HDR	04726	3428-2002
A2 J5	1251-3119	2	1	CONN-POST-TP-HDR	04726	3428-2002
A2 K1	0490-1412	9	1	RLY-REED 1A	11263	3570.1332.053
A2 K2	0490-1412	9	1	RLY-REED 1A	11263	3570.1332.053
A2 K3	0490-1412	9	1	RLY-REED 1A	11263	3570.1332.053
A2 K4	0490-1412	9	1	RLY-REED 1A	11263	3570.1332.053
A2 L1	9170-0894	0	1	CORE-SHLD BEAD	06337	56-590-65/4A6
A2 L2	9170-0894	0	1	CORE-SHLD BEAD	06337	56-590-65/4A6
A2 Q1	1854-1028	6	1	XSTR NPN SI	02037	2N3904
A2 Q2	1853-0563	0	1	XSTR PNP SI	02037	2N3906(SEL)
A2 Q3	1854-0472	2	1	XSTR NPN SI DARL	02037	MPS-A14
A2 Q4	1854-0472	2	1	XSTR NPN SI DARL	02037	MPS-A14
A2 Q5	1853-0563	0	1	XSTR PNP SI	02037	2N3906(SEL)
A2 Q6	1854-1028	6	1	XSTR NPN SI	02037	2N3904
A2 Q7	1853-0563	0	1	XSTR PNP SI	02037	2N3906(SEL)

Table A-9.
Option 001 HP 8116A Control Board Parts List (continued)

Reference	HP Part #	CD	Qty	Description	Manuf'r	Part #
A2 R1	0757-0200	7	1	RES 5.62K 1%	05524	CMF-55-1, T-1
A2 R2	2100-0554	5	1	RES-TRMR 500 10%	03744	3386P-Y46-501
A2 R3	0757-0420	3	1	RES 750 1% .125W	05524	CMF-55-1, T-1
A2 R4	2100-3210	6	1	RES-TRMR 10K 10%	03744	3386P-Y46-103
A2 R6	0698-4123	5	1	RES 499 1% .125W	05524	CMF-55-1, T-1
A2 R7	0698-4014	3	1	RES 787 1% .125W	05524	CMF-55-1, T-1
A2 R8	0757-0283	6	1	RES 2K 1% .125W	05524	CMF-55-1, T-1
A2 R9	0757-0449	6	1	RES 20K 1% .125W	05524	CMF-55-1, T-1
A2 R10	0757-0472	5	1	RES 200K 1%	05524	CMF-55-1, T-1
A2 R11	0698-8827	4	1	RES 1M 1% .125W	05524	CMF-55-1
A2 R12	0698-8827	4	1	RES 1M 1% .125W	05524	CMF-55-1
A2 R13	0698-3444	1	1	RES 316 1% .125W	05524	CMF-55-1, T-1
A2 R14	0698-3258	5	1	RES 5.36K 1%	05524	CMF-55-1, T-1
A2 R15	0698-4014	3	1	RES 787 1% .125W	05524	CMF-55-1, T-1
A2 R16	1810-0316	1	1	NETWORK-RES DIP	02483	761-3-R10K
A2 R17	2100-3214	0	1	RES-TRMR 100K	03744	3386P-Y46-104
A2 R18	2100-3214	0	1	RES-TRMR 100K	03744	3386P-Y46-104
A2 R19	0757-0428	1	1	RES 1.62K 1%	05524	CMF-55-1, T-1
A2 R20	0698-3446	3	1	RES 383 1% .125W	05524	CMF-55-1, T-1
A2 R21	1810-0470	8	1	NETWORK-RES DIP	02483	761-3-R2.2K
A2 R22	2100-3214	0	1	RES-TRMR 100K	03744	3386P-Y46-104
A2 R23	0757-0476	9	1	RES 301K 1%	05524	CMF-55-1, T-1
A2 R24	2100-3211	7	1	RES-TRMR 1K 10%	03744	3386P-Y46-102
A2 R25	2100-3214	0	1	RES-TRMR 100K	03744	3386P-Y46-104
A2 R26	0757-0476	9	1	RES 301K 1%	05524	CMF-55-1, T-1
A2 R27	2100-3211	7	1	RES-TRMR 1K 10%	03744	3386P-Y46-102
A2 R28	0698-4442	1	1	RES 4.42K 1%	05524	CMF-55-1, T-1
A2 R29	0757-0417	8	1	RES 562 1% .125W	05524	CMF-55-1, T-1
A2 R30	0757-0273	4	1	RES 3.01K 1%	05524	CMF-55-1, T-1
A2 R31	2100-0567	0	1	RES-TRMR 2K 10%	03744	3386P-Y46-202

Table A-9.
Option 001 HP 8116A Control Board Parts List (continued)

Reference	HP Part #	CD	Qty	Description	Manuf'r	Part #
A2 R32	2100-0567	0	1	RES-TRMR 2K 10%	03744	3386P-Y46-202
A2 R33	0757-0458	7	1	RES 51.1K 1%	05524	CMF-55-1, T-1
A2 R35	0757-0401	0	1	RES 100 1% .125W	05524	CMF-55-1, T-1
A2 R36	0757-0401	0	1	RES 100 1% .125W	05524	CMF-55-1, T-1
A2 R37	0757-0442	9	1	RES 10K 1% .125W	05524	CMF-55-1, T-1
A2 R38	0698-4424	9	1	RES 1.4K 1%	05524	CMF-55-1, T-1
A2 R39	0757-0442	9	1	RES 10K 1% .125W	05524	CMF-55-1, T-1
A2 R40	0757-0280	3	1	RES 1K 1% .125W	05524	CMF-55-1, T-1
A2 R41	0698-6360	6	1	RES 10K .1%	05524	CMF-55-1, T-9
A2 R42	0698-6360	6	1	RES 10K .1%	05524	CMF-55-1, T-9
A2 R43	2100-3252	6	1	RES-TRMR 5K 10%	03744	3386P-Y46-502
A2 R44	0757-0465	6	1	RES 100K 1%	05524	CMF-55-1, T-1
A2 R45	0698-3155	1	1	RES 4.64K 1%	05524	CMF-55-1, T-1
A2 R46	0757-0465	6	1	RES 100K 1%	05524	CMF-55-1, T-1
A2 R47	0698-4486	3	1	RES 24.9K 1%	05524	CMF-55-1, T-1
A2 R48	0698-4487	4	1	RES 25.5K 1%	05524	CMF-55-1, T-1
A2 R50	1810-0206	8	1	NETWORK-RES SIP	02483	750-81
A2 R51	0757-0280	3	1	RES 1K 1% .125W	05524	CMF-55-1, T-1
A2 R52	0698-3452	1	1	RES 147K 1%	05524	CMF-55-1, T-1
A2 R54	0757-0277	8	1	RES 49.9 1%	05524	CMF-55-1, T-1
A2 R55	0757-0280	3	1	RES 1K 1% .125W	05524	CMF-55-1, T-1
A2 R56	0698-6324	2	1	RES 187 1% .125W	05524	CMF-55-1, T-1
A2 R57	0757-0280	3	1	RES 1K 1% .125W	05524	CMF-55-1, T-1
A2 R58	0757-0280	3	1	RES 1K 1% .125W	05524	CMF-55-1, T-1
A2 R59	1810-0243	3	1	NETWORK-RES DIP	02483	761-3-R6.8K
A2 R60	1810-0205	7	1	NETWORK-RES SIP	02483	750-81
A2 R61	1810-0206	8	1	NETWORK-RES SIP	02483	750-81
A2 R62	1810-0203	5	1	NETWORK-RES SIP	02483	750-81
A2 R63	1810-0203	5	1	NETWORK-RES SIP	02483	750-81
A2 R64	1810-0203	5	1	NETWORK-RES SIP	02483	750-81

Table A-9.
Option 001 HP 8116A Control Board Parts List (continued)

Reference	HP Part #	CD	Qty	Description	Manuf'r	Part #
A2 R65	0698-3441	8	1	RES 215 1% .125W	05524	CMF-55-1, T-1
A2 R66	0757-0428	1	1	RES 1.62K 1%	05524	CMF-55-1, T-1
A2 R67	0757-0428	1	1	RES 1.62K 1%	05524	CMF-55-1, T-1
A2 R68	0757-0442	9	1	RES 10K 1% .125W	05524	CMF-55-1, T-1
A2 R70	0757-0410	1	1	RES 301 1% .125W	05524	CMF-55-1, T-1
A2 R71	0757-0410	1	1	RES 301 1% .125W	05524	CMF-55-1, T-1
A2 R72	0757-0410	1	1	RES 301 1% .125W	05524	CMF-55-1, T-1
A2 TP1	0360-2264	6	1	TERM.-TEST POINT	10358	1095D
A2 TP2	0360-2264	6	1	TERM.-TEST POINT	10358	1095D
A2 TP3	0360-2264	6	1	TERM.-TEST POINT	10358	1095D
A2 TP4	0360-2264	6	1	TERM.-TEST POINT	10358	1095D
A2 TP5	0360-2264	6	1	TERM.-TEST POINT	10358	1095D
A2 TP6	0360-2264	6	1	TERM.-TEST POINT	10358	1095D
A2 TP7	0360-2264	6	1	TERM.-TEST POINT	10358	1095D
A2 TP8	0360-2264	6	1	TERM.-TEST POINT	10358	1095D
A2 TP9	0360-2264	6	1	TERM.-TEST POINT	10358	1095D
A2 TP10	0360-2264	6	1	TERM.-TEST POINT	10358	1095D
A2 U1	1826-0519	9	1	IC 071	01698	TL071CP
A2 U2	1826-0519	9	1	IC 071	01698	TL071CP
A2 U3	1820-1885	2	1	IC-DM74LS173AN	03406	DM74LS173AN
A2 U4	1826-0276	5	1	IC MC78L05ACP	02037	MC78L05ACP
A2 U5	1826-0600	9	1	IC 074A	01698	TL074ACN
A2 U6	1826-0729	3	1	D/A 10-BIT	03285	AD7522JN
A2 U7	1826-0635	0	1	IC OP-07C	02180	OP-07CP
A2 U8	1826-0639	4	1	D/A 8-BIT	03285	AD7524JN
A2 U9	1826-0635	0	1	IC OP-07C	02180	OP-07CP
A2 U10	1826-0639	4	1	D/A 8-BIT	03285	AD7524JN
A2 U11	1826-0635	0	1	IC OP-07C	02180	OP-07CP
A2 U12	1826-0521	3	1	IC 072	01698	TL072CP
A2 U13	1826-0729	3	1	D/A 10-BIT	03285	AD7522JN

Table A-9.
Option 001 HP 8116A Control Board Parts List (continued)

Reference	HP Part #	CD	Qty	Description	Manuf'r	Part #
A2 U14	1820-1216	3	1	IC-SN74LS138N	01698	SN74LS138N
A2 U15	1820-1730	6	1	IC-SN74LS273N	01698	SN74LS273N
A2 U16	1826-0501	9	1	ANLG MUXR	02037	MC14053BCP
A2 U17	1826-0501	9	1	ANLG MUXR	02037	MC14053BCP
A2 U18	1820-1730	6	1	IC-SN74LS273N	01698	SN74LS273N
A2 U19	1820-1199	1	1	IC-SN74LS04N	01698	SN74LS04N
A2 U20	1820-1216	3	1	IC-SN74LS138N	01698	SN74LS138N
A2 U21	1820-1730	6	1	IC-SN74LS273N	01698	SN74LS273N
A2 U22	1820-1730	6	1	IC-SN74LS273N	01698	SN74LS273N
A2 U23	1820-1730	6	1	IC-SN74LS273N	01698	SN74LS273N
A2 U24	1826-0697	4	1	D/A 12-BIT	03285	AD7541JN
A2 U25	1826-0635	0	1	IC OP-07C	02180	OP-07CP
A2 U26	1826-0635	0	1	IC OP-07C	02180	OP-07CP
A2 U27	1826-0729	3	1	D/A 10-BIT	03285	AD7522JN
A2 U28	1826-0521	3	1	IC 072	01698	TL072CP
A2 U29	1826-0729	3	1	D/A 10-BIT	03285	AD7522JN
A2 U30	1826-0521	3	1	IC 072	01698	TL072CP
A2 U31	1826-0180	0	1	IC-NE555N	02910	NE555N
A2 U32	1820-0801	0	1	IC-MC10101P	02037	MC10101P
A2 U33	1820-1400	7	1	IC-MC10104P	02037	MC10104P
A2 U34	1820-1400	7	1	IC-MC10104P	02037	MC10104P
A2 U35	1820-0820	3	1	IC-MC10135L	02037	MC10135L
A2 U36	1820-0820	3	1	IC-MC10135L	02037	MC10135L
A2 U37	1820-1686	1	1	IC-MC10103P	02037	MC10103P
A2 U38	1820-1052	5	1	IC-MC10125L	02037	MC10125L
A2 U39	1820-1282	3	1	IC-SN74LS109AN	01698	SN74LS109AN
A2 U40	1820-1197	9	1	IC-SN74LS00N	01698	SN74LS00N
A2 U41	1820-1278	7	1	IC-SN74LS191N	01698	SN74LS191N
A2 U42	1820-1278	7	1	IC-SN74LS191N	01698	SN74LS191N
A2 U43	1820-1730	6	1	IC-SN74LS273N	01698	SN74LS273N

Table A-9.
Option 001 HP 8116A Control Board Parts List
(continued)

Reference	HP Part #	CD	Qty	Description	Manuf'r	Part #
A2 VR1	1902-0786	4	1	DIO-ZNR 1N937	02688	
A2 VR2	1902-0949	1	1	DIO-ZNR 4.3V 5%	02037	
A2 W2	8159-0005	0	1	RES 0 CWM	01339	L-2007-1
A2 W3	8159-0005	0	1	RES 0 CWM	01339	L-2007-1

**Keyboard
Opt 001**

Table A-10. Option 001 HP 8116A Keyboard Parts List

Reference	HP Part #	CD	Qty	Description	Manuf'r	Part #
A4	08116-66514	0	1	BD AY-KEY OPT	28480	08116-66514
A4 DS1	1990-0665	3	1	LED-LMP	01542	
A4 DS2	1990-0665	3	1	LED-LMP	01542	
A4 DS3	1990-0665	3	1	LED-LMP	01542	
A4 DS4	1990-0665	3	1	LED-LMP	01542	
A4 DS5	1990-0665	3	1	LED-LMP	01542	
A4 DS6	1990-0665	3	1	LED-LMP	01542	
A4 DS7	1990-0665	3	1	LED-LMP	01542	
A4 DS8	1990-0665	3	1	LED-LMP	01542	
A4 DS9	1990-0665	3	1	LED-LMP	01542	
A4 DS10	1990-0665	3	1	LED-LMP	01542	
A4 DS11	1990-0665	3	1	LED-LMP	01542	
A4 DS12	1990-0665	3	1	LED-LMP	01542	
A4 DS13	1990-0665	3	1	LED-LMP	01542	
A4 DS14	1990-0665	3	1	LED-LMP	01542	
A4 DS15	1990-0665	3	1	LED-LMP	01542	
A4 DS16	1990-0665	3	1	LED-LMP	01542	
A4 DS17	1990-0665	3	1	LED-LMP	01542	
A4 DS18	1990-0665	3	1	LED-LMP	01542	
A4 J1	1251-6255	3	1	CONN-POST-TP-SKT	03418	22-14-2204
A4 J2	1251-6255	3	1	CONN-POST-TP-SKT	03418	22-14-2204
A4 J3	1251-7410	4	1	CONN-POST-TP-SKT	03418	22-14-2054
A4 MP1	5041-0309	5	1	CAP KEY QUARTER	28480	5041-0309
A4 MP2	5041-0309	5	1	CAP KEY QUARTER	28480	5041-0309
A4 MP3	5041-0309	5	1	CAP KEY QUARTER	28480	5041-0309
A4 MP4	5041-0351	7	1	KEY CAP SRF-G L	28480	5041-0351
A4 MP5	5041-0351	7	1	KEY CAP SRF-G L	28480	5041-0351
A4 MP6	5041-0351	7	1	KEY CAP SRF-G L	28480	5041-0351
A4 MP7	5041-0726	0	1	KEY CAP LCL	28480	5041-0726
A4 MP8	5041-0285	6	1	KEY CAP PRL-G L	28480	5041-0285

Table A-10.
Option 001 HP 8116A Keyboard Parts List (continued)

Reference	HP Part #	CD	Qty	Description	Manuf'r	Part #
A4 MP9	5041-0285	6	1	KEY CAP PRL-G L	28480	5041-0285
A4 MP10	5041-0285	6	1	KEY CAP PRL-G L	28480	5041-0285
A4 MP11	5041-0276	5	1	KEY CAP PRL-GRA	28480	5041-0276
A4 MP12	5041-0276	5	1	KEY CAP PRL-GRA	28480	5041-0276
A4 MP13	5041-0351	7	1	KEY CAP SRF-G L	28480	5041-0351
A4 MP14	5041-0351	7	1	KEY CAP SRF-G L	28480	5041-0351
A4 MP15	5041-0285	6	1	KEY CAP PRL-G L	28480	5041-0285
A4 MP16	5041-0285	6	1	KEY CAP PRL-G L	28480	5041-0285
A4 MP17	5041-0285	6	1	KEY CAP PRL-G L	28480	5041-0285
A4 MP18	5041-0351	7	1	KEY CAP SRF-G L	28480	5041-0351
A4 MP19	5041-0351	7	1	KEY CAP SRF-G L	28480	5041-0351
A4 MP20	5041-0285	6	1	KEY CAP PRL-G L	28480	5041-0285
A4 MP21	5041-0285	6	1	KEY CAP PRL-G L	28480	5041-0285
A4 MP22	5041-0285	6	1	KEY CAP PRL-G L	28480	5041-0285
A4 MP23	5041-0285	6	1	KEY CAP PRL-G L	28480	5041-0285
A4 MP24	5041-0285	6	1	KEY CAP PRL-G L	28480	5041-0285
A4 S1	5060-9436	7	1	SW-PB SPST NO	04486	5560-9436
A4 S2	5060-9436	7	1	SW-PB SPST NO	04486	5560-9436
A4 S3	5060-9436	7	1	SW-PB SPST NO	04486	5560-9436
A4 S4	5060-9436	7	1	SW-PB SPST NO	04486	5560-9436
A4 S5	5060-9436	7	1	SW-PB SPST NO	04486	5560-9436
A4 S6	5060-9436	7	1	SW-PB SPST NO	04486	5560-9436
A4 S7	5060-9436	7	1	SW-PB SPST NO	04486	5560-9436
A4 S8	5060-9436	7	1	SW-PB SPST NO	04486	5560-9436
A4 S9	5060-9436	7	1	SW-PB SPST NO	04486	5560-9436
A4 S10	5060-9436	7	1	SW-PB SPST NO	04486	5560-9436
A4 S11	5060-9436	7	1	SW-PB SPST NO	04486	5560-9436
A4 S12	5060-9436	7	1	SW-PB SPST NO	04486	5560-9436
A4 S13	5060-9436	7	1	SW-PB SPST NO	04486	5560-9436
A4 S14	5060-9436	7	1	SW-PB SPST NO	04486	5560-9436

Table A-10.
Option 001 HP 8116A Keyboard Parts List (continued)

Reference	HP Part #	CD	Qty	Description	Manuf'r	Part #
A4 S15	5060-9436	7	1	SW-PB SPST NO	04486	5560-9436
A4 S16	5060-9436	7	1	SW-PB SPST NO	04486	5560-9436
A4 S17	5060-9436	7	1	SW-PB SPST NO	04486	5560-9436
A4 S18	5060-9436	7	1	SW-PB SPST NO	04486	5560-9436
A4 S19	5060-9436	7	1	SW-PB SPST NO	04486	5560-9436
A4 S20	5060-9436	7	1	SW-PB SPST NO	04486	5560-9436
A4 S21	5060-9436	7	1	SW-PB SPST NO	04486	5560-9436
A4 S22	5060-9436	7	1	SW-PB SPST NO	04486	5560-9436
A4 S23	5060-9436	7	1	SW-PB SPST NO	04486	5560-9436
A4 S24	5060-9436	7	1	SW-PB SPST NO	04486	5560-9436
A4 W1	5180-2403	8	1		28480	5180-2403

**Display Board
Opt 001**

Table A-11. Option 001 HP 8116A Display Board Parts List

Reference	HP Part #	CD	Qty	Description	Manuf'r	Part #
A5	08116-66515	1	1	BD AY-DISPL OPT	28480	08116-66515
A5 DS1	1990-0486	6	1	LED-LMP	01542	HLMP-1301
A5 DS2	1990-0774	5	1	LED-LT BAR	01542	HLMP-2600(D,E,F)
A5 DS3	1990-0774	5	1	LED-LT BAR	01542	HLMP-2600(D,E,F)
A5 DS4	1990-0774	5	1	LED-LT BAR	01542	HLMP-2600(D,E,F)
A5 DS5	1990-0774	5	1	LED-LT BAR	01542	HLMP-2600(D,E,F)
A5 DS6	1990-0774	5	1	LED-LT BAR	01542	HLMP-2600(D,E,F)
A5 DS7	1990-0774	5	1	LED-LT BAR	01542	HLMP-2600(D,E,F)
A5 DS8	1990-0806	4	1	LED-LT BAR	01542	HLMP-2300(SELECTED)
A5 DS15	1990-0486	6	1	LED-LMP	01542	HLMP-1301
A5 DS16	1990-0486	6	1	LED-LMP	01542	HLMP-1301
A5 DS17	1990-0486	6	1	LED-LMP	01542	HLMP-1301
A5 DS18	1990-0806	4	1	LED-LT BAR	01542	HLMP-2300(SELECTED)
A5 DS19	1990-0486	6	1	LED-LMP	01542	HLMP-1301
A5 DS20	1990-0486	6	1	LED-LMP	01542	HLMP-1301
A5 DS21	1990-0486	6	1	LED-LMP	01542	HLMP-1301
A5 DS22	1990-0486	6	1	LED-LMP	01542	HLMP-1301
A5 DS23	1990-0486	6	1	LED-LMP	01542	HLMP-1301
A5 DS24	1990-0486	6	1	LED-LMP	01542	HLMP-1301
A5 DS25	1990-0486	6	1	LED-LMP	01542	HLMP-1301
A5 DS26	1990-0486	6	1	LED-LMP	01542	HLMP-1301
A5 DS27	1990-0486	6	1	LED-LMP	01542	HLMP-1301
A5 DS28	1990-0486	6	1	LED-LMP	01542	HLMP-1301
A5 DS29	1990-0486	6	1	LED-LMP	01542	HLMP-1301
A5 DS30	1990-0486	6	1	LED-LMP	01542	HLMP-1301
A5 DS31	1990-0486	6	1	LED-LMP	01542	HLMP-1301
A5 DS32	1990-0486	6	1	LED-LMP	01542	HLMP-1301
A5 DS33	1990-0486	6	1	LED-LMP	01542	HLMP-1301
A5 DS34	1990-0486	6	1	LED-LMP	01542	HLMP-1301
A5 DS35	1990-0486	6	1	LED-LMP	01542	HLMP-1301

Table A-11.
Option 001 HP 8116A Display Board Parts List (continued)

Reference	HP Part #	CD	Qty	Description	Manuf'r	Part #
A5 DS36	1990-0486	6	1	LED-LMP	01542	HLMP-1301
A5 DS37	1990-0486	6	1	LED-LMP	01542	HLMP-1301
A5 DS38	1990-0486	6	1	LED-LMP	01542	HLMP-1301
A5 DS39	1990-0486	6	1	LED-LMP	01542	HLMP-1301
A5 DS40	1990-0486	6	1	LED-LMP	01542	HLMP-1301
A5 DS41	1990-0846	2	1	DISPLAY-NUM-SEG	01542	
A5 DS42	1990-0846	2		DISPLAY-NUM-SEG	01542	
A5 DS43	1990-0846	2		DISPLAY-NUM-SEG	01542	
A5 DS44	1990-0846	2		DISPLAY-NUM-SEG	01542	
A5 J1	1251-7431	9	1	CONN-POST-TP-HDR	08839	5920575
A5 J2	1251-7431	9	1	CONN-POST-TP-HDR	08839	5920575
A5 J3	1251-7429	5	1	CONN-POST-TP-HDR	08839	5905575
A5 S1	3101-2529	1	1	SW-RKR DPDT	08360	326.2-01
A5 S2	3101-2529	1	1	SW-RKR DPDT	08360	326.2-01
A5 S3	3101-2529	1	1	SW-RKR DPDT	08360	326.2-01
A5 S4	3101-2529	1	1	SW-RKR DPDT	08360	326.2-01

Backdating

Backdating information is only required for instruments with a serial number *lower* than that shown on the front page of this manual.

Introduction

This appendix contains backdating information to adapt this manual for instruments with a serial number *lower* than that shown on the title page. There are two series of serial numbers, a “G” series and an “A” series. Only the digits following the letter are important when deciding which changes apply to your instrument. If your instrument has a higher serial number than that shown on the title page, refer to Appendix C instead.

To adapt this manual for an earlier instrument, look up your serial number in Table B-1 and implement the changes from the **latest** back to the earliest change which applies to your instrument.

Where changes to components occur, modify the appropriate schematic and component layout accordingly.

Note



Some components may have been changed more than once during the production of the HP 8116A. Therefore Hewlett-Packard suggests you make the modifications to the manual in pencil as you work through the changes for your instrument.

Table B-1. Backdating Changes

Instrument Serial No.		Implement Changes From 76 to:	Instrument Serial No.		Implement Changes From 76 to:	
G Series	A Series		G Series	A Series		
G00129,118,117, 116,109 and lower	A00101 to 324	1	G03171 to 3220	A01536 to 1955 A01956 to 3614 A03615 to 4478 A04479 to 5450 A05451 to 8235	38	
G00130 to 140		2	G03221 to 3222		39	
G00141 to 160		3	G03223 to 3395		40	
G00161 to 170		4	G03396 to 3545		41	
and			G03546 to 3570		42	
194,189,180,176			G03571 to 3745		43	
G00195 to 285		5	G03746 to 3920		44	
G00286 to 365		6	G03921 to 4045		45	
G00366 to 405		7	G04046 to 4120		46	
G00406 to 505		8	G04121 to 4377		47	
G00506 to 565		9	G04378 to 4420		48	
G00566 to 635		10	G04421 to 4445		49	
G00636 to 695		11	G04445 to 4620		50	
G00696 to 755		12	G04621 to 4795		51	
G00756 to 815		13	G04796 to 5070		52	
G00816 to 1035		14	G05071 to 5095		53	
G01036 to 1085		15	G05096 to 5170		54	
G01086 to 1185		16	G05171 to 5195		55	
G01186 to 1235		17	G05196 to 5420		56	
G01236 to 1285		18	G05421 to 5445		57	
G01286 to 1335		19	G05446 to 5470		58	
G01336 to 1485		20	G05471 to 5545		59	
G01486 to 1735		21	G05546 to 5645		60	
G01736 to 1905		22	G05646 to 6295		61	
G01906 to 1940		23	G06296 to 6395		62	
G01941 to 2085		24	G06396 to 6495		63	
G02086 to 2145		25	G06496 to 6945		64	
G02146 to 2295		26	G06946 to 7495		65	
G02296 to 2345		27	G07496 to 7545		66	
G02346 to 2495		28	G07546 to 7595		67	
		A00325 to 1535	29		G07596 to 7795	68
G02496 to 2545			30		G07796 to 7895	69
G02546 to 2570			31		G07896 to 8595	70
G02571 to 2620			32		G08596 to 8645	71
G02621 to 2645			33		G08646 to 8720	72
G02645 to 2670			34		G08721 to 10470	73
G02671 to 2845	35					
G02846 to 2895	36					
G02896 to 3120	37					
G03121 to 3170						

Note



From serial number 2901G10771 onward, any changes made to circuit board assemblies were indicated by an *Engineering Date Code* (EDC) Label on the relevant board.

Table B-2. Backdating Changes

Instrument Serial No. G Series	Board EDC Label	Implement Changes From 76 to:
G10471 to 10770	A-3119	74
G10771 to 11345	A-3119	75
G11346 to 11520	A-3127	76

Change 1

For instruments with serial numbers 2124G00129, 118, 117, 116, 109 and lower, make the following changes to the parts-list for the Main Board assembly A1 (Table A-3):

	Reference	Description	HP Part #
A1 08116-66501	VR200	DIO ZNR 5.11 V 5%	1902-0041
	R226	RES 1.62K 1%	0757-0428
	R240	RES 3.32K 1%	0757-0433
	R243	RES 2.05K 1%	0698-4431
	R411	RES 1.47K 1%	0757-1094

Change 2

For instruments with serial numbers 2124G00140 and lower, make the following changes to the appropriate parts-lists:

Main Board In Table A-3 *modify*:

	Reference	Description	HP Part #
A1 08116-66501	C406	CAP 100 pF	0160-4389
	C407	CAP 100 pF	0160-4389
	C525	CAP 4.7 pF	0160-3873
	C527	CAP 33 pF	0160-4386
	C532	CAP 22 pF	0160-3875
	R123*	RES 511 Ω 1%	0757-0416
	R228	RES 11 Ω 1%	0757-0378
	R309*	RES 51.1K 1%	0757-0394
	R412	RES 511 Ω	0698-7229
	R421	RES 1K	0698-7236
	W1	Jumper	8159-0005
	W2	Jumper	8159-0005

In Table A-3 *add*:

Reference	Description	HP Part #
R557	RES 56.2 Ω	0698-7206
L506	CORE MAG	9170-0894
L507	CORE MAG	9170-0894

In Table A-3 *delete*:

	Reference	Description	HP Part #
A1 08116-66501	C539 F1,F2 R558 - 560		

Control Board In Table A-4 *delete*:

	Reference	Description	HP Part #
A2 08116-66502	C29		

In Table A-9 *delete*:

	Reference	Description	HP Part #
A2 08116-66502	C27 - 30 L1,2		

Change 3

For instruments with serial number 2124G00160 and lower, make the following changes to the appropriate parts-lists:

Main Board In Table A-3:

	Reference	Description	HP Part #
A1 08116-66501	C501	CAP 0.1 μ F 20%	0160-0576

Change 4

1. For instruments with serial number 2124G00194 and lower, make the following changes to the appropriate parts-lists:

Instrument In Table A-2:

	Reference	Description	HP Part #
A0 08116	A1	BD AY-MAIN	08116-66501

Main Board In Table A-3 *modify*:

	Reference	Description	HP Part #
A1 08116-66501	R528	RES 825 Ω 1%	0757-0428
	R529	RES 825 Ω 1%	0757-0428
	R541	RES 825 Ω 1%	0757-0428
	R542	RES 825 Ω 1%	0757-0428
	R513	RES 5.25K 1%	0698-7258
	R422	RES 6.19K 1%	0757-0290

In Table A-3 *delete*:

	Reference	Description	HP Part #
A1 08116-66501	R445 - 453	RES	

Control Board In Table A-4 and Table A-9 *add*:

	Reference	Description	HP Part #
A2 08116-66502	R49	RES-VAR 2K 10%	2100-0567

2. Change the following steps in the Shaper Adjustment Procedure:

- 5 Adjust A1R410 until the measured voltage is 5.060 V \pm 30 mV.
- 7 Check that the measured voltage is > 8.06 V.
- 9 Adjust A2R49 until the measured voltage is 0.506 V \pm 3 mV.
- 18 Check that the measured voltage is > 4.64 V.
- 33 Adjust A1R418 until the measured voltage is 3.532 V \pm 10 mV.
- 35 Check that the measured voltage is 0.354 V \pm 5 mV.
- 52 Check that the measured voltage is 0.510 V \pm 5 mV.
- 60 Check that the harmonics are < -27 dB in both cases.

3. Change the following steps in the Offset Adjustment Procedure:

- 4 Adjust A2R43 until the measured voltage is 7.95 V \pm 50 mV.
- 6 Check that the measured voltage is -7.95 V \pm 50 mV.

Change 5

For instruments with serial number 2124G00285 and lower, make the following changes to the appropriate parts-lists:

Main Board In Table A-3 *modify*:

	Reference	Description	HP Part #
A1 08116-66511	C216	CAP 15 pF 200 V	0160-4385
	R226	RES 2.15K 1%	0698-0084

Control Board In Table A-4 and Table A-9 *delete*:

	Reference	Description	HP Part #
A2 08116-66502	R70	RES 150 Ω 1%	0757-0284
	R71	RES 150 Ω 1%	0757-0284
	R72	RES 150 Ω 1%	0757-0284

Change 6

For instruments with serial number 2124G00365 and lower, make the following changes to the appropriate parts-lists:

Instrument In Table A-2:

	Reference	Description	HP Part #
A0 08116	MP2	SHAFT PWR SW	08112-43701

Main Board In Table A-3 *modify*:

	Reference	Description	HP Part #
A1 08116-66511	R205	RES 196 Ω 1%	0698-7219
	R206	RES 100 Ω 1%	0698-7212
	R415	RES 75 Ω 1%	0698-7209
	R421	RES 511 Ω 1%	0698-7229
	R588	RES 51.1 Ω 1%	0698-7205
	C401	CAP 4700 pF 20%	0160-0573

In Table A-3 *add*:

	Reference	Description	HP Part #
A1 08116-66511	Q400	XSTR SEL PAIR	5180-2409
	MP400	COVER TRAINS	0340-0530

In Table A-3 *delete*:

	Reference	Description	HP Part #
A1 08116-66511	R437	RES 1.54K 1%	0698-4425
	C231		
	Q401		
	W9		
	MP4		
	L261		
	C262		

Microprocessor Board In Table A-5 *delete*:

	Reference	Description	HP Part #
A3 08116-66503	C9	CAP 0.1 μ F 20%	0160-0567

Change 7

For instruments with serial number 2124G00405 and lower, make the following changes to the appropriate parts-lists:

Instrument In Table A-2:

	Reference	Description	HP Part #
A0 08116	MP8	FRAME REAR	5020-8814

Control Board In Table A-4 and Table A-9 *delete*:

	Reference	Description	HP Part #
A2 08116-66502	C31	CAP 0.1 μ F 20%	0160-0576

In Table A-4 and Table A-9 *modify*:

	Reference	Description	HP Part #
A2 08116-66502	R30	RES 3.83K 1%	0698-3153
	U24	IC LIN D/A CONV	1826-0874

Change 8

For instruments with serial number 2124G00505 and lower, make the following changes to the appropriate parts-lists:

Instrument In Table A-2 *modify*:

	Reference	Description	HP Part #
A0 08116	MP9	PNL REAR	08116-60253

Main Board In Table A-3 *modify*:

	Reference	Description	HP Part #
A1 08116-66511	R157	RES 4.75K 1%	0757-0437
	R508	RES 64.9K 1%	0698-4502

Control Board In Table A-4 & Table A-9:

	Reference	Description	HP Part #
A2 08116-66502	R45	RES 4.22K 10%	0698-3154

Change 9

For instruments with serial number 2124G00565 and lower, make the following changes to the appropriate parts-lists:

Main Board In Table A-3 *modify*:

	Reference	Description	HP Part #
A1 08116-66511	R123	RES 442 Ω 1%	0698-3488

In Table A-3 *delete*:

	Reference	Description	HP Part #
A1 08116-66511	R428	RES 14.7K 1%	0698-7264

Display Board In Table A-7 and Table A-11 *modify*:

	Reference	Description	HP Part #
A5 08116-66505	DS41	DISPLAY NUM	1990-0531
(08116-66515)	DS42	DISPLAY NUM	1990-0531
	DS43	DISPLAY NUM	1990-0531
	DS40	DISPLAY	1990-0649

Change 10

For instruments with serial number 2124G00635 and lower (2334A00324 and lower), make the following changes to the appropriate parts-lists:

Main Board In Table A-3 *modify*:

	Reference	Description	HP Part #
A1 08116-66511	R220	RES 2.37K 1%	0698-3150
	R223	RES 2.37K 1%	0698-3150
	R242	RES 1.1K 1%	0757-0424

In Table A-3 *delete*:

	Reference	Description	HP Part #
A1 08116-66511	C264	CAP 1 nF 100 V	0160-3878

Change 11

For instruments with serial number 2124G00695 and lower (2334A00324 and lower), make the following changes to the appropriate parts-lists:

Main Board In Table A-3 *delete*:

	Reference	Description	HP Part #
A1 08116-66511	R429	RES 31.6K 1%	0698-7272
	RT1	THMS 5K	0837-0035
	R235	RES 1M 10%	0698-4073
	R236	RES 1M 10%	0698-4073
	R237	RES 1M 10%	0698-4073
	R238	RES 1M 10%	0698-4073
	R239	RES 1M 10%	0698-4073

In Table A-3 *modify*:

Reference	Description	HP Part #
MP200	HEAT SINK	1205-0018
C502	CAP 68 pF 200 V	0160-4512

Microprocessor Board

Make the following changes to the schematic for the microprocessor board in Chapter 10.3 :

1. U13 Pin 9: Change from ground to \overline{EVMA} .
2. U13 Pin 7: Change from VMA to +5 V.
3. U12 Pins 4, 5: Change from ground to \overline{EVMA} .
4. U12 Pin 6: Change from VMA to +5 V.

Change 12

For instruments with serial number 2124G00755 and lower (2334A00324 and lower), make the following changes to the appropriate parts-lists:

Main Board In Table A-3 *delete*:

	Reference	Description	HP Part #
A1 08116-66511	C408	CAP 0.1 μ F 20%	0160-0576
	C540	CAP 0.1 μ F 20%	0160-0576

Change 13

For instruments with serial number 2124G00815 and lower (2334A00324 and lower), make the following changes to the appropriate parts-lists:

Main Board In Table A-3 *add*:

	Reference	Description	HP Part #
A1 08116-66511	R429	RES 31.6K 1%	0698-7272
	RT1	THMS 5K	0837-0035

In Table A-3 *modify*:

	Reference	Description	HP Part #
	R439	RES 6.2K 1%	0757-0447

Change 14

For instruments with serial number 2124G01035 and lower (2334A00324 and lower), make the following changes to the appropriate parts-lists:

Main Board In Table A-3 *delete*:

	Reference	Description	HP Part #
A1 08116-66511	Q504	XSTR SI 2N4209	1853-0405

In Table A-3 *modify*:

	Reference	Description	HP Part #
	Q503	XSTR MATCH.PAIR	5080-1083

Change 15

For instruments with serial number 2124G01085 and lower (2334A00324 and lower), make the following changes to the appropriate parts-lists:

Main Board In Table A-3 *modify*:

	Reference	Description	HP Part #
	Q504	XSTR SI 2N4209	1853-0405
	C502	CAP 68 pF 200 V	0160-4350

Control Board In Table A-4 and Table A-9 *modify*:

	Reference	Description	HP Part #
A2 08116-66502	VR2	DIO ZNR 6.2 V	1902-0953

Change 16

For instruments with serial number 2124G01185 and lower (2334A00324 and lower), make the following changes to the appropriate parts-lists:

Main Board In Table A-3 *modify*:

	Reference	Description	HP Part #
A1 08116-66511	C502	CAP 120 pF 200 V	0160-4512
	C525	CAP 6.8 pF 200 V	0160-4383
	C527	CAP 39 pF 200 V	0160-4494
	R553	RES 21.5 Ω 2%	0698-7196
	U401	IC SHAPER	5180-2416
	F1/F2	FUSE 0.5 A	2110-0538

Control Board In Table A-4 and Table A-9 *modify*:

	Reference	Description	HP Part #
A2 08116-66502	R43	RES VAR 2K 10%	2100-0567

Microprocessor Board In Table A-5 *modify*:

	Reference	Description	HP Part #
A3 08116-66503	U35	IC SN74LS04	1820-1199

Change 17

Note



For instruments with serial numbers 2124G01235 and lower (2334A00324 and lower) you must perform the following check:

1. Switch HP 8116A on.
2. Select E.WID mode and sine output (This will give an error condition).
3. Switch the instrument off and on again.
4. Select pulse output.
5. Select the WID parameter.

If the displayed value is 100 μ s, you must implement this backdating change as the instrument still has its original ROMs fitted.

If the displayed value is 500 μ s, ignore this backdating change as the instrument has had its original ROMs replaced.

Microprocessor Board

1. In Table A-5 *modify*:

	Reference	Description	HP Part #
A3 08116-66503	U5	ROM B	08116-10001
	U6	ROM A	08116-10002
	U7	ROM 9	08116-10003
	U8	ROM 8	08116-10004
	U9	ROM 7	08116-10005
	U38	ROM 6	08116-10006

2. In “Introduction” in Chapter 6 change the text to:

- It is not necessary to put a comma between commands, a space will do.
- The HP 8116A understands upper and lower case commands.
- The HP 8116A processes commands in the order in which they are received.

The HP 8116A can be programmed into an error condition in the same ways as when using the front panel. To avoid causing error conditions, and hence SRQs, you must make sure that each command received by the HP 8116A is compatible with its current settings.

For example, assume that the instrument is currently set for HIL = 2 V and LOL = 0 V, and you want to program HIL = 4 V and LOL = 2.5 V.

You *must* put the HIL 4 V command first in the programming message, otherwise the LOL of 2.5 V will be incompatible with the current HIL of 2 V.

Refer to “Error, Fault and Status Reporting” in Chapter 6 for a details of error, fault and status reporting in via the HP-IB.

3. In “Timing Error (Bit 0)” in Chapter 6 change the text to:

IERR Description	Comments
WIDTH ERROR	<ul style="list-style-type: none"> ■ This error occurs if you request an invalid combination of frequency and pulse width so that: $WID > 1/FRQ$. ■ The instrument’s output changes. ■ You can use the SR0 command to stop this error generating a timing error and an SRQ. To re-enable it, use the SR1 command. The response to IERR is not affected.
TIMING ERROR	<ul style="list-style-type: none"> ■ This error can only occur with Opt 001 in I.BUR mode. ■ This error occurs if you request an invalid combination of frequency, burst number and repeat time so that: $BUR \times 1/FRQ > RPT$. ■ The instrument’s output changes. ■ You can use the SR0 command to stop this error generating a timing error and an SRQ. To re-enable it, use the SR1 command. The response to IERR is not affected.

4. In “Autovernier” in Chapter 6 change the table to:

Action	Mnemonic
Switch off autovernier	A0
Switch on autovernier	A1
Most significant digit up	MU
Second significant digit up	SU
Least significant digit up	LU
Most significant digit down	MD
Second significant digit down	SD
Least significant digit down	LD
Range up	RU
Range down	RD

5. Make sure that the text in Chapter 10.7 on trouble-shooting the ROM has been modified as given in “Change 61”. Then change Table 10.7-5 to:

Table 10.7-5 ROM signatures 08116-1000X Series

ROM:	U5	U6	U7	U8	U9	U38
Start/Stop:	TP6	TP5	TP4	TP3	TP2	TP1
Pin						
9	H66F	2790	125A	9UF6	UU53	313C
10	24PF	7AUA	60H2	26F4	8F34	4UUP
11	HH90	047F	F631	355U	7012	46P0
13	50PH	CC4H	449C	C825	A6U5	8H90
14	143P	U42C	18UF	C8H6	8U8U	UP5F
15	961F	5453	0P45	70U4	H204	7079
16	5U79	4U95	22FA	94P3	1AF7	3AA8
17	C92H	79FF	FF08	3981	77A3	UF58
24	P254	P254	P254	P254	P254	P254

Change 18

For instruments with serial number 2124G01285 and lower (2334A00324 and lower), make the following changes to the appropriate parts-lists:

Main Board In Table A-3 *modify*:

	Reference	Description	HP Part #
A1 08116-66511	R215	RES 681 1%	0757-0419

Change 19

For instruments with serial number 2124G01335 and lower (2334A00324 and lower):

1. Make the following changes to the appropriate parts-lists:

Main Board In Table A-3 *modify*:

	Reference	Description	HP Part #
A1 08116-66511	Q210	XSTR SI 2N3904	1854-0215
	C502	CAP 68 PF 200 V	0160-4350
	R445	RES VAR 200K 1%	2100-3213
	R447	RES 23.7K 1%	0698-3158

In Table A-3 add:

	Reference	Description	HP Part #
A1 08116-66511	R448	RES VAR 500K 10%	2100-0580

2. Figure B-1 shows R448's location in the circuit and on the main board. Modify Figure 9-8, Figure 10.4-9 and Figure 10.4-4 accordingly.

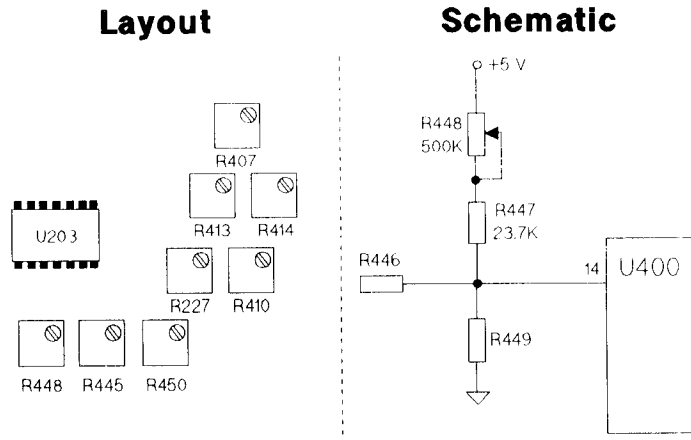

Figure B-1. R448

3. Change or add the following steps in the Shaper Adjustment procedure:
- 33 Adjust A1R448 until the measured voltage is $3.532\text{ V} \pm 1\text{ mV}$. If A1R448 is too sensitive to achieve optimum adjustment, turn A1R418 clockwise a little.
 - 40b Connect the HP 8116A's main output via a $50\ \Omega$ feedthrough terminator to the DVM.
 - 40c Set up the HP 8116A as follows:

FRQ	1.00 kHz
AMP	16.0 V
 - 40d Readjust A1R448 until the measured voltage is $5.660\text{ V} \pm 1\text{ mV}$.

Change 20

For instruments with serial number 2124G01485 and lower (2334A00324 and lower):

1. Make the following changes to the appropriate parts-lists:

Main Board

In Table A-3 *modify*:

	Reference	Description	HP Part #
A1 08116-66511	C221	CAP .1 μ F CER 20%	0160-0576
	C222	CAP .1 μ F CER 20%	0160-0576

In Table A-3 *delete*:

	Reference	Description	HP Part #
A1 08116-66511	CR513	DIODE PWR 1 kV 1A	1901-0732
	CR514	DIODE PWR 1 kV 1A	1901-0732
	R561	RES 3.16K .125 W 1%	0757-0279

2. In “Power Supply “& Preliminary Adjustments” in Chapter 9, step 2, modify the table entry for A1R19 to read:

Testpoint	Adjust	Result
A1-23 V	A1R19	-23.000 V \pm 50 mV

3. Change -24 V to -23 V throughout the manual.

Change 21

For instruments with serial number 2124G01735 and lower (2334A00324 and lower):

1. Make the following changes to the appropriate parts-lists:

Main Board

In Table A-3 *modify*:

	Reference	Description	HP Part #
A1 08116-66511	U200	IC-TL 074 ACN	1826-0600

Control Board

In Table A-4 and Table A-9 *modify*:

	Reference	Description	HP Part #
A2 08116-66502	U5	IC-TL 074 ACN	1826-0600

Microprocessor Board In Table A-5 *modify*:

	Reference	Description	HP Part #
A3 08116-66503	U5	ROM B	08116-10011
	U6	ROM A	08116-10012
	U7	ROM 9	08116-10013
	U8	ROM 8	08116-10014
	U9	ROM 7	08116-10015
	U38	ROM 6	08116-10016

2. Make sure that the text in Chapter 10.7 on trouble-shooting the ROM has been modified as given in "Change 61". Then change Table 10.7-5 to:

Table 10.7-5 ROM signatures 08116-1001X Series

ROM:	U5	U6	U7	U8	U9	U38
Start/Stop:	TP6	TP5	TP4	TP3	TP2	TP1
Pin						
9	278A	P726	873U	A4P3	HHU5	55FU
10	6A4H	PPAC	4H66	AC35	001P	384F
11	4731	U658	H178	7H9P	FA3H	H52H
13	U9H8	H7A7	30A9	9H70	936H	PH16
14	6344	CP5F	459U	61U7	64PA	6517
15	PCC0	9P52	2F1A	3061	A738	01FC
16	8P11	A30C	9C95	FH3C	PC47	P77H
17	9A08	H5UU	3719	C0C9	C5CF	HCH4
24	P254	P254	P254	P254	P254	P254

Change 22

For instruments with serial number 2124G01905 and lower (2334A00324 and lower), make the following changes to the appropriate parts-lists:

Control Board In Table A-4 and Table A-9:

	Reference	Description	HP Part #
A2 08116-66502	R30	RES 3.83K 1%	0698-3153
	R33	RES 4.87K 1%	0698-4444
	VR2*	DIO-ZNR 6.2 V	1902-0952

Change 23

For instruments with serial number 2124G01940 and lower (2334A00324 and lower):

1. Make the following changes to the appropriate parts-lists:

Main Board

In Table A-3 *modify*:

Reference	Description	HP Part #
R123	RES 402 Ω .125 W 1%	0698-4453

In Table A-3 *delete*:

	Reference	Description	HP Part #
A1 08116-66511	C235 C264 R130		

2. In Table 9-1 add the following:

Procedure	Reference	Range	Description
VCO	A1R123	383 Ω – 536 Ω	Decreasing the value decreases the HF duty cycle

3. Change or add the following steps in the Voltage Controlled Oscillator Adjustment Procedure:

- 49 Set up the HP 8116A as follows:

Waveform	Square
FRQ	10.0 MHz

- 50 Check that the duty cycle is < 60%. If not, change the value of A1R123 (Refer to Table 9-1).

Change 24

For instruments with serial number 2124G02085 and lower (2334A00324 and lower), make the following changes to the appropriate parts-lists:

Main Board In Table A-3 *modify*:

	Reference	Description	HP Part #
	C235	CAP 68 PF 200 V	0160-4350

Microprocessor Board In Table A-5 *delete*:

	Reference	Description	HP Part #
A3 08116-66503	TP8	TERM TEST POINT	0360-0535
	W2	JUMPER	8159-0005

Change 25

For instruments with serial number 2124G02145 and lower (2334A00324 and lower), make the following changes to the appropriate parts-lists:

Microprocessor Board In Table A-5 *modify*:

	Reference	Description	HP Part #
A3 08116-66503	R15,16	NETWORK-RES 47K	1810-0378

Change 26

For instruments with serial number 2124G02295 and lower (2334A00324 and lower):

1. Make the following changes to the appropriate parts-lists:

Control Board In Table A-4 and Table A-9 *add*:

	Reference	Description	HP Part #
A2 08116-66502	C31	CAP 0.1 UF 20%	0160-0576

- Figure B-2 shows the location of C31 in the circuit and on the control board. Modify Figure 10.5-6 and Figure 10.5-8 accordingly.

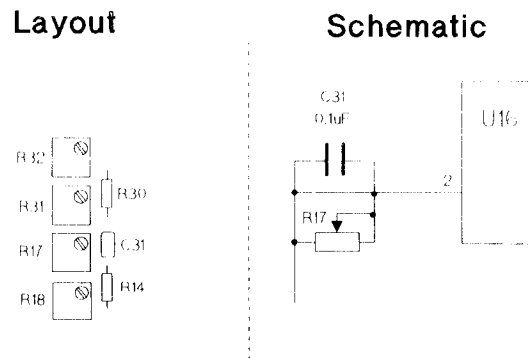

Figure B-2. C31

Change 27

For instruments with serial number 2124G02345 and lower (2334A00324 and lower), make the following changes to the appropriate parts-lists:

Main Board In Table A-3 *modify*:

	Reference	Description	HP Part #
A1 08116-66511	R404	RES 261 Ω .125 W 1%	0698-3132
	R408	RES 261 Ω .125 W 1%	0698-3132
	R405	RES 1.62K 1%	0757-0428
	R406	RES 1.62K 1%	0757-0428
	C502	CAP 120 pF 5%	0160-4512
	C530	CAP 1 pF 200 V	0160-4380
	C531	CAP 2.2 pF 200 V	0160 3872
	CR505	DIO SI 15 V 75 ns	1901-0179
	CR506	DIO SI 15 V 75 ns	1901-0179
	Q510	XSTR NPN 2N3866A	1854-0784
	Q512	XSTR NPN 2N3866A	1854-0784
	Q511	XSTR PNP 2N5160	1853-0312
	Q513	XSTR PNP 2N5160	1853-0312

In Table A-3 *add*:

	Reference	Description	HP Part #
A1 08116-66511	C525	CAP 1.5 pF 200 V 1%	0160-4381
	C538	CAP 1.5 pF 200 V 1%	0160-4381
	C540	CAP .1 μ F 20%	0160-0576
	R556	RES 237 Ω .05 W 1%	0698-7221

Note



These components were deleted in “Change 30” and “Change 46”, therefore you need to restore them in Figure 10.4-8 and Figure 10.4-9. You must also restore them in the schematic Figure 10.4-5 and components list *with the above values*.

In Table A-3 *delete*:

	Reference	Description	HP Part #
A1 08116-66511	C541	CAP .01 μ F 100 V	0160-3879

Change 28

For instruments with serial number 2124G02495 and lower (2334A00324 and lower), make the following changes to the appropriate parts-lists:

Main Board

In Table A-3 *modify*:

	Reference	Description	HP Part #
A1 08116-66511	R536	RES 261 Ω .05 W 1%	0698-7222

Change 29

For instruments with serial number 2124G02545 and lower (2334A00324 and lower), make the following changes to the appropriate parts-lists:

Main Board

In Table A-3 *modify*:

	Reference	Description	HP Part #
A1 08116-66511	R220	RES 2.74 K 1%	0757-0281
	R223	RES 2.74 K 1%	0757-0281

Change 30

For instruments with serial number 2124G02570 and lower (2334A00324 and lower), make the following changes to the appropriate parts-lists:

Main Board In Table A-3 *modify*:

	Reference	Description	HP Part #
A1 08116-66511	C105	CAP 0.1 μ F CER 20%	0160-0576
	C530	CAP 1.5 pF 200 V	0160-4381

In Table A-3 *delete*:

	Reference	Description	HP Part #
A1 08116-66511	C525*	CAP 6.8 pF	0160-5738
	C538	CAP 1.5 pF	0160-4381
	R556	RES 19.6 Ω	0698-7195

Change 31

For instruments with serial number 2124G02620 and lower (2334A00324 and lower), make the following changes to the appropriate parts-lists:

Control Board In Table A-4 and Table A-9 *add*:

	Reference	Description	HP Part #
A2 08116-66502	R70 - 72	RES 150 Ω .125 W 1%	0757-0284

Note



R70 - 72 were deleted in "Change 60", therefore you need to restore them in layout Figure 10.5-8, in the schematic Figure 10.5-5 and in the components list *with the above value*.

Microprocessor Board In Table A-5 *modify*:

	Reference	Description	HP Part #
A3 08116-66503	U17	IC-SN74LS138N	1820-1216

Change 32

For instruments with serial number 2124G02645 and lower (2334A00324 and lower), make the following changes to the appropriate parts-lists:

Main Board In Table A-3 *modify*:

	Reference	Description	HP Part #
A1 08116-66511	C112,113	CAP 6.8 μ F TA 35 V	0180-0116

Change 33

For instruments with serial number 2124G02670 and lower (2334A00324 and lower), make the following changes to the appropriate parts-lists:

Main Board In Table A-3 *modify*:

	Reference	Description	HP Part #
A1 08116-66511	R226	RES 2.05K 1%	0698-4431

Change 34

For instruments with serial number 2124G02845 and lower (2334A00324 and lower), make the following changes to the appropriate parts-lists:

Main Board In Table A-3 *modify*:

	Reference	Description	HP Part #
A1 08116-66511	R406	RES 1.3 K 1%	0757-0426
	R408	RES 267 1%	0698-4446

Change 35

For instruments with serial number 2124G02895 and lower (2334A00324 and lower):

1. Make the following changes to the appropriate parts-lists:

Microprocessor Board

In Table A-5 *modify*:

	Reference	Description	HP Part #
A3 08116-66503	U5	ROM B	08116-10021
	U6	ROM A	08116-10022
	U7	ROM 9	08116-10023
	U8	ROM 8	08116-10024
	U9	ROM 7	08116-10025
	U38	ROM 6	08116-10026

Change 36

For instruments with serial number 2124G03120 and lower (2334A00324 and lower), make the following changes to the appropriate parts-lists:

Main Board

In Table A-3 *delete*:

	Reference	Description	HP Part #
A1 08116-66511	C409	CAP 22 pF 200 V 5%	0160-3875
	CR401	DIO-SCHOTTKY SM	1901-0518
	CR402	DIO-SCHOTTKY SM	1901-0518
	R454	RES 61.9 Ω .125 W 1%	0757-0276

Change 37

For instruments with serial number 2124G03170 and lower (2334A00324 and lower), make the following changes to the appropriate parts-lists:

Main Board

In Table A-3 *modify*:

	Reference	Description	HP Part #
A1 08116-66511	R219	RES 7.5K .125 W 1%	0757-0440
	R222	RES 7.5K .125 W 1%	0757-0440

Change 38

For instruments with serial number 2124G03220 and lower (2334A00324 and lower):

1. Make the following changes to the appropriate parts-lists:

Main Board

2. In Table A-3 *modify*:

	Reference	Description	HP Part #
A1 08116-66511	C306	CAP .01 μ F 100 V	0160-3879
	R310*	RES 2K .125% 1%	0757-0283

In Table A-3 *delete*:

	Reference	Description	HP Part #
A1 08116-66511	C307		
	CR303		
	CR304		
	R311		

In Table A-3 *add*:

	Reference	Description	HP Part #
A1 08116-66511	C305	CAP 0.1 μ F CER 20%	0160-0576

Note



- C305 replaces C307 on the component layout Figure 10.4-8.
- C305 also replaces C307 on the schematic Figure 10.3-7, but connected between pins 23 and 24 of U300 instead of between pin 24 and ground.

-
- Change the following steps in the Width Adjustment procedure:
 - Adjust A2R32 until the measured time is $98.0 \mu\text{s} +2/-1 \mu\text{s}$.
 - Adjust A1R304 until the measured time is $980 \mu\text{s} +20/-10 \mu\text{s}$.
 - Adjust A2R31 until the measured time is $99.9 \text{ ns} \pm 1 \text{ ns}$.

Change 39

For instruments with serial number 2124G03222 and lower (2334A00324 and lower):

1. Make the following changes to the appropriate parts-lists:

Main Board In Table A-3 *modify*:

	Reference	Description	HP Part #
A1 08116-66511	Q210	XSTR SI 2N5088	1854-0392
	R202	NETWORK-RES 680 Ω	1810-0332
	R215	RES 3.48K 1%	0698-3152

In Table A-3 *delete*:

	Reference	Description	HP Part #
A1 08116-66511	Q216		
	R273		
	R274		
	R275		
	R276		
	R277		

Change 40

For instruments with serial number 2124G03395 and lower (2334A00324 and lower), make the following changes to the appropriate parts-lists:

Main Board In Table A-3 *modify*:

	Reference	Description	HP Part #
A1 08116-66511	Q401	XSTR SI PNP	1853-0075

Change 41

For instruments with serial number 2124G03545 and lower (2334A00324 and lower):

1. Make the following changes to the appropriate parts-lists:

Microprocessor Board In Table A-5 *modify*:

	Reference	Description	HP Part #
A3 08116-66503	U10	IC RAM 444C	1818-1330

In Table A-5 *delete*:

	Reference	Description	HP Part #
A3 08116-66503	R21		
	U39		

In Table A-5 *add*:

	Reference	Description	HP Part #
A3 08116-66503	U11	IC RAM 444C	1818-1330

2. Figure B-3 shows the location of the RAMs U10 and U11 on the microprocessor board 08116-65503. Modify Figure 10.7-9 accordingly.

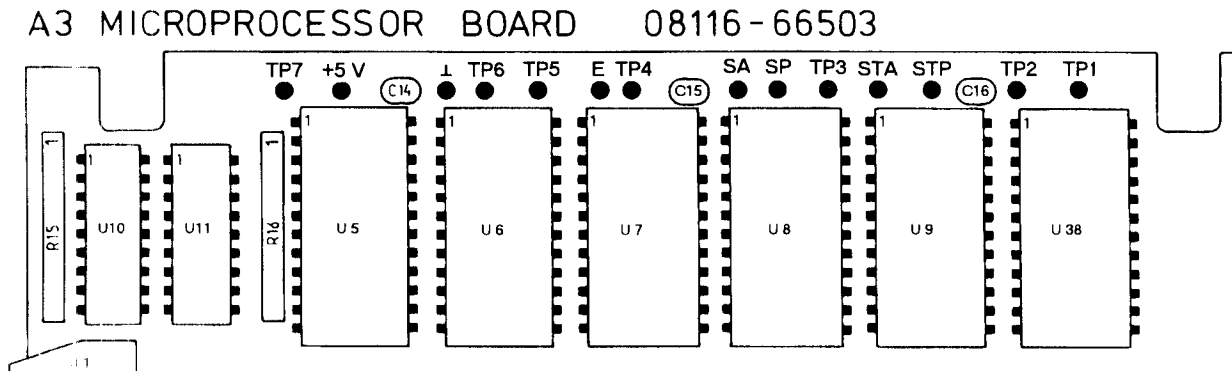

Figure B-3. 08116-66503: U10, U11 layout

3. Figure B-4 shows the RAM circuit on the microprocessor board 08116-65503. Modify Figure 10.7-5 accordingly.

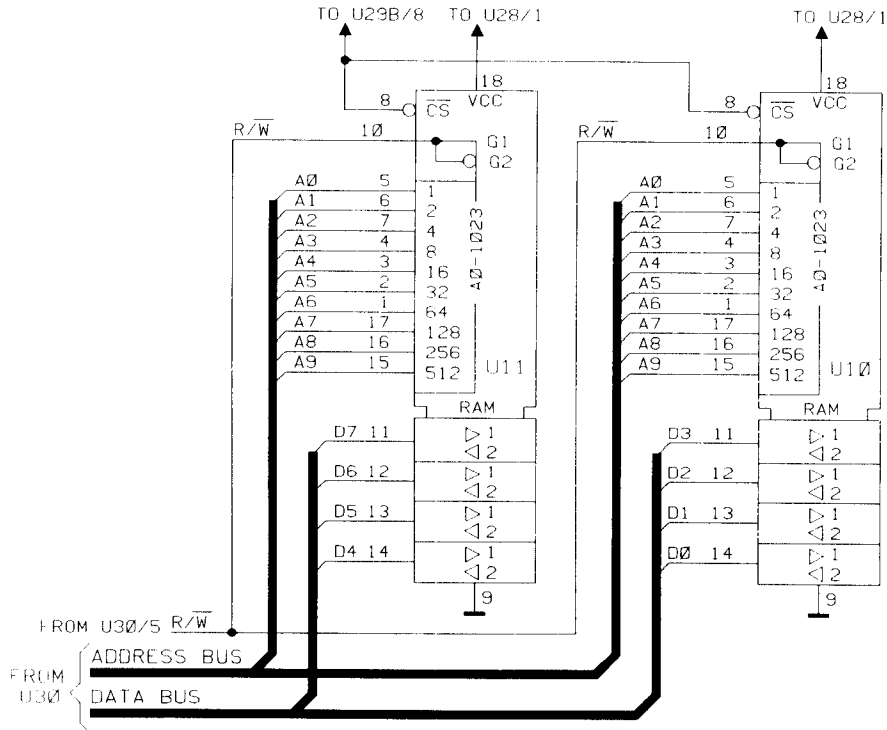

Figure B-4. 08116-66503: U10, U11 schematic

Change 42

For instruments with serial number 2124G03570 and lower (2334A00324 and lower), make the following changes to the appropriate parts-lists:

Main Board In Table A-3 *modify*:

	Reference	Description	HP Part #
A1 08116-66511	R400	RES 15.4K 1%	0698-3540
	R436	RES 5.36K 1%	0698-3258

Change 43

For instruments with serial number 2334G03745 and lower (2516A01535 and lower), make the following changes to the appropriate parts-lists:

Instrument In Table A-2:

	Reference	Description	HP Part #
A0 08116	MP4	PANEL SUB	08116-00202
	MP7	FRAME FRONT	5020-8813
	MP8	FRAME REAR	08116-21103
	MP12	SIDE STRUT 17 IN	5020-8831
	MP13	SIDE STRUT 17 IN	5020-8831
	MP17	COVER BOTOM	08112-04158
	MP18	COVER TOP 31/2#M	08116-04101

Change 44

For instruments with serial number 2520G03920 and lower (2537A01955 and lower):

1. Make the following changes to the appropriate parts-lists:

Instrument In Table A-2 *modify*:

	Reference	Description	HP Part #
A0 08116	A3	BD AY-MICROPROCESSOR	08116-66503

Microprocessor Board In Table A-5 *delete*:

	Reference	Description	HP Part #
A3 08116-66503	W5		8159-0005

Change 45

For instruments with serial number 2520G04045 and lower (2537A01955 and lower), make the following changes to the appropriate parts-lists:

Main Board In Table A-3 *modify*:

	Reference	Description	HP Part #
A1 08116-66511	R242	RES 1.15K 1%	0698-4469

Change 46

For instruments with serial number 2520G04120 and lower (2537A01955 and lower), make the following changes to the appropriate parts-lists:

Main Board In Table A-3 *modify*:

	Reference	Description	HP Part #
A1 08116-66511	C406	CAP 120 pF 5%	0160-4512
	C409*	CAP 22 pF 200 V 5%	0160-3875

In Table A-3 *delete*:

	Reference	Description	HP Part #
A1 08116-66511	C410		
	C540		

Change 47

For instruments with serial number 2520G04377 and lower (2537A01955 and lower):

1. Make the following changes to the appropriate parts-lists:

Instrument In Table A-2 *modify*:

	Reference	Description	HP Part #
A0 08116	A2	BD AY-CONTR	08116-66502

**Instrument
(Option 001)**

In Table A-8 *modify*:

	Reference	Description	HP Part #
A0 08116	A2	BD AY-CONTR	08116-66512

Control Board

In Table A-4 and Table A-9 *modify*:

	Reference	Description	HP Part #
A2 08116-66522	K1 - 4	RELAY-REED 1 A	0490-1137

In Table A-9 *delete*:

	Reference	Description	HP Part #
A2 08116-66522	R68 CR20		

In Table A-9 *add*:

	Reference	Description	HP Part #
A2 08116-66522	CR1 - 4	DIO-SWIT 1N4150	1901-1098

- Figure B-5 shows the location of CR1 - 4 in the circuit and on the control board. Modify Figure 10.5-5 and Figure 10.5-8 accordingly.

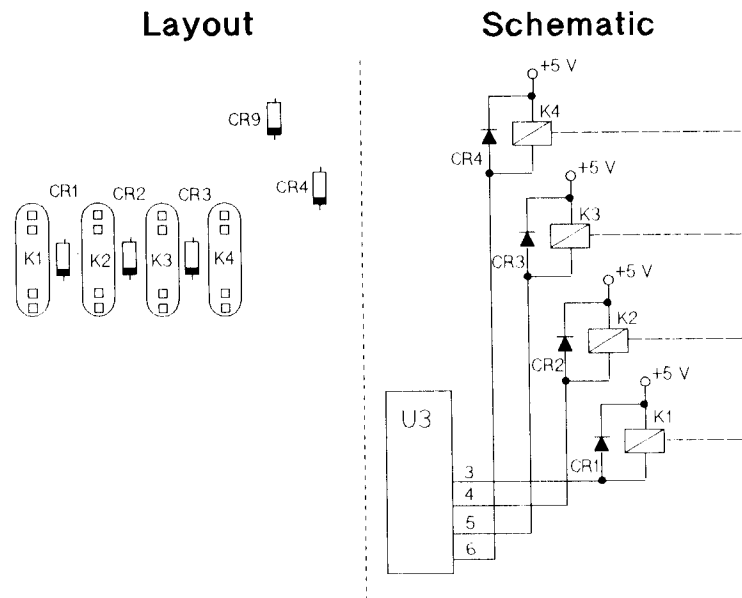

Figure B-5. CR1 - 4

Change 48

For instruments with serial number 2520G04420 and lower (2537A01955 and lower), make the following changes to the appropriate parts-lists:

Main Board In Table A-3 *modify*:

	Reference	Description	HP Part #
A1 08116-66511	L502	CORE MAGNETIC	9170-0894

Change 49

For instruments with serial number 2520G04445 and lower (2537A01955 and lower), make the following changes to the appropriate parts-lists:

Main Board In Table A-3 *modify*:

	Reference	Description	HP Part #
A1 08116-66511	R220*	RES 2.74K 1%	0757-0281

Change 50

For instruments with serial number 2520G04620 and lower (2537A01955 and lower):

1. Make the following changes to the appropriate parts-lists:

Instrument In Table A-2 *modify*:

	Reference	Description	HP Part #
A0 08116	A2	BD AY-MAIN	08116-66511
	MP18	COVER TOP	08116-04102

Main Board In Table A-3 *modify*:

	Reference	Description		HP Part #
A1 08116-66511	K201	RELAY-REED	1 A	0490-1137
	K202	RELAY REED	1 A	0490-1137
	K501 - 506	RELAY-REED	1 A	0490-1137
	CR513,514	DIO-PWR 1 kV	1 A	1901-0732
	C409*	CAP 22 pF 200 V	5%	0160-3875
	C502	CAP 150 pF 200 V	5%	0160-4547
	R19	RES-TRMR 1K	10%	2100-3211
	R24	RES-VAR 500 Ω .5 W	10%	2100-0554

In Table A-3 *delete*:

	Reference	Description	HP Part #
A1 08116-66511	CR515,516		
	VR504 - 507		
	W12 - 14		
	C551 - 554		
	L506,507		
	R593,594		

In Table A-3 *add*:

	Reference	Description		HP Part #
A1 08116-66511	CR201,202	DIO-SWIT 1N4150		1901-1098
	CR507 - 512	DIO-SWIT 1N4150		1901-1098
	R20	RES 3.65K	1%	0757-0434

- Figure B-6 shows CR201's location in the circuit and on the main board. Modify Figure 10.3-6 and Figure 10.4-8 accordingly.

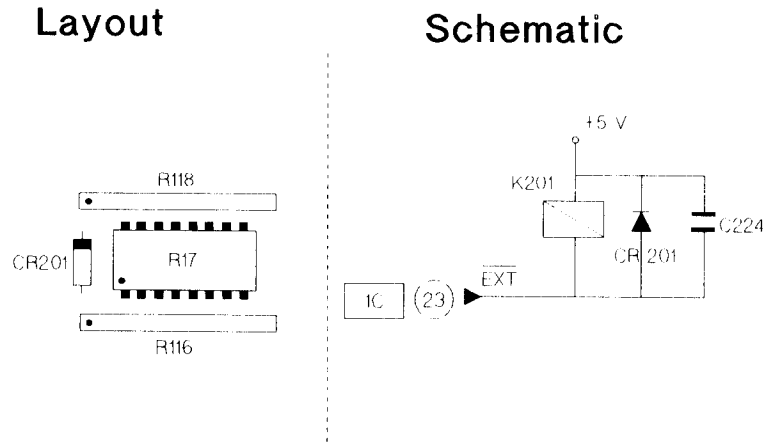

Figure B-6. CR201

- Figure B-7 shows CR202's location in the circuit and on the main board. Modify Figure 10.3-5 and Figure 10.4-8 accordingly.

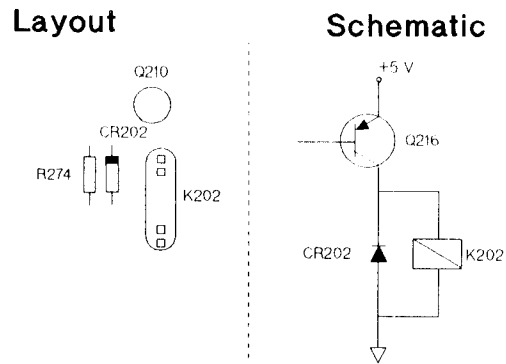

Figure B-7. CR202

4. Figure B-8 shows the location of CR507 - 512 in the circuit and on the main board. Modify Figure 10.4-4 and Figure 10.4-8 accordingly.

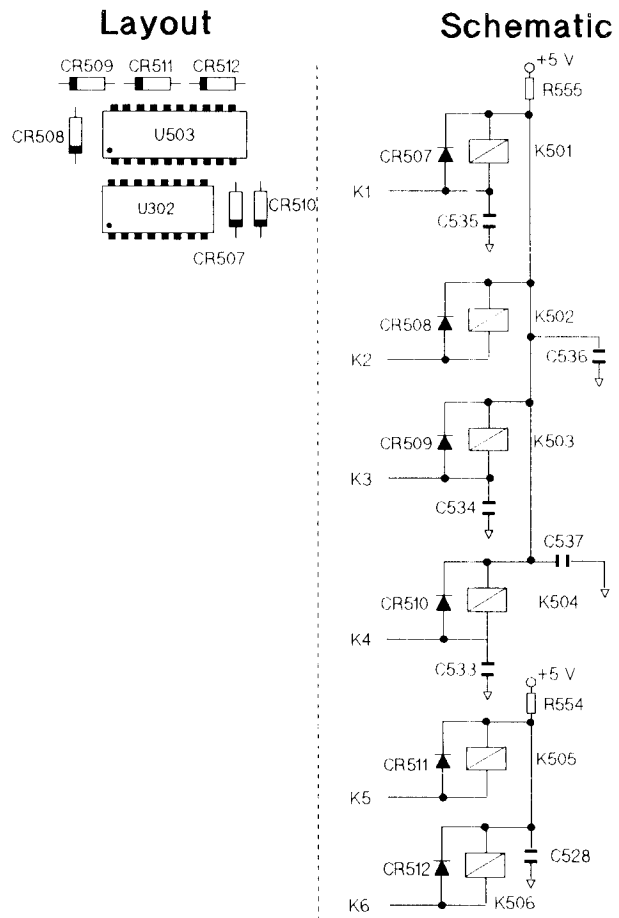

Figure B-8. CR507

5. Figure B-9 shows the location of R20 in the circuit and on the main board. Modify Figure 10.2-3 and Figure 10.4-8 accordingly.

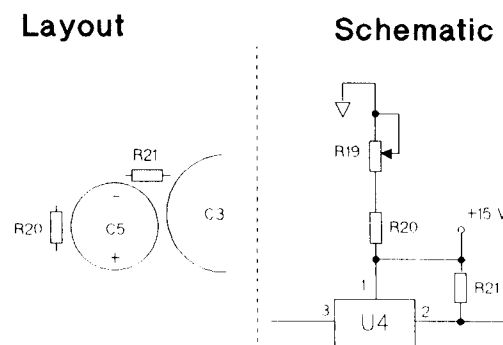

Figure B-9. R20

Change 51

For instruments with serial number 2520G04795 and lower (2537A01955 and lower):

1. Make the following changes to the appropriate parts-lists:

Main Board In Table A-3 *modify*:

	Reference	Description	HP Part #
A1 08116-66521	C409*	CAP 15 pF 200 V 5%	0160-5736
	C502*	CAP 100 pF 200 V 5%	0160-4389
	C539*	CAP 100 pF 5%	0160-4389

In Table A-3 *delete*:

	Reference	Description	HP Part #
A1 08116-66521	C555*		

In Table A-3 *add*:

	Reference	Description	HP Part #
A1 08116-66521	C553	CAP 1.5 pF 200 V	0160-4381

Note



C553 was deleted in “Change 70”, therefore you need to restore it in layout Figure 10.4-8, in the schematic Figure 10.4-5 and in the components list *with the above value*.

Change 52

For instruments with serial number 2520G05070 and lower (2708A03614 and lower), make the following changes to the appropriate parts-lists:

Main Board In Table A-3 *modify*:

	Reference	Description	HP Part #
A1 08116-66521	MP501	HT-SINK SGL	1205-0329

Microprocessor Board

In Table A-5 *delete*:

	Reference	Description	HP Part #
A3 08116-66513	CR5 Q2 R22,23		8159-0005

Change 53

For instruments with serial number 2520G05095 and lower (2708A03614 and lower):

1. Make the following changes to the appropriate parts-lists:

Main Board

In Table A-3 *modify*:

	Reference	Description	HP Part #
A1 08116-66521	L260	COIL-CHOKE .39 μ H	9100-2254

In Table A-3 *add*:

	Reference	Description	HP Part #
A1 08116-66521	L261	CORE MAGNETIC	9170-0894

2. Figure B-10 shows the location of L261 in the circuit and on the main board. Modify Figure 10.4-5 and Figure 10.4-8 accordingly.

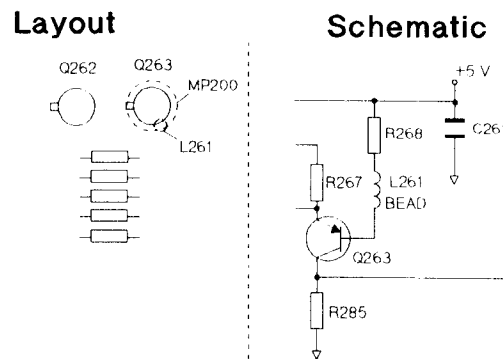

Figure B-10. L261

Change 54

For instruments with serial number 2520G05170 and lower (2708A03614 and lower), make the following changes to the appropriate parts-lists:

Main Board In Table A-3 *modify*:

	Reference	Description	HP Part #
A1 08116-66521	J2	CONN 20 PIN RBN	1251-3119

Microprocessor Board In Table A-5 *modify*:

	Reference	Description	HP Part #
A3 08116-66513	J1	CONN 50 PIN RBN	1251-3141
	J2	CONN 34 PIN RBN	1251-0541

Change 55

For instruments with serial number 2520G05195 and lower (2708A03614 and lower), make the following changes to the appropriate parts-lists:

Instrument In Table A-2 *modify*:

	Reference	Description	HP Part #
A0 08116	MP8	FRAME REAR	5021-0512

Main Board In Table A-3 *modify*:

	Reference	Description	HP Part #
A1 08116-66521	C300*	CAP 10 pF 200 V	0160-3874
	R309*	RES 100 Ω .125 W 1%	0757-0401

Change 56

For instruments with serial number 2520G05420 and lower (2708A04478 and lower), make the following changes to the appropriate parts-lists:

Instrument In Table A-2 *modify*:

	Reference	Description	HP Part #
A0 08116	A1	BD AY-MAIN	08116-66521

Main Board In Table A-3 *modify*:

	Reference	Description	HP Part #
A1 08116-66521	R423*	RES 147 Ω .125 W 1%	0698-3438
	R427*	RES 147 Ω .125 W 1%	0698-3438
	R226	RES 1.87K 1%	0698-4429
	R436	RES 7.5K 1%	0698-0440

Change 57

For instruments with serial number 2520G05445 and lower (2708A04478 and lower), make the following changes to the appropriate parts-lists:

Main Board In Table A-3 *modify*:

	Reference	Description	HP Part #
A1 08116-66531	C525*	CAP 6.8 pF	0160-5738
	R423	RES 1.1K .125 W 1%	0757-0424
	R427	RES 1.1K .125 W 1%	0757-0424

Change 58

For instruments with serial number 2520G05470 and lower (2708A04478 and lower), make the following changes to the appropriate parts-lists:

Instrument In Table A-2 *modify*:

	Reference	Description	HP Part #
A0 08116	MP8	FRAME REAR	5021-5814

Change 59

For instruments with serial number 2520G05545 and lower (2708A04478 and lower), make the following changes to the appropriate parts-lists:

Main Board In Table A-3 *modify*:

	Reference	Description	HP Part #
A1 08116-66531	R219*	RES 10K .125 W 1%	0757-0442
	R222*	RES 10K .125 W 1%	0757-0442
	C531*	CAP 2.7 pF 200 V	0160-3568
	C406	CAP 100 pF	0160-5730

Change 60

For instruments with serial number 2520G05645 and lower (2708A04478 and lower), make the following changes to the appropriate parts-lists:

Instrument In Table A-2:

	Reference	Description	HP Part #
A0 08116	MP4	PNL-SUB	08116-00204

Main Board In Table A-3 *delete*:

	Reference	Description	HP Part #
A1 08116-66531	RC556*		

Control Board In Table A-9 *delete*:

	Reference	Description	HP Part #
A2 08116-66522	R70 - 72		

Change 61

For instruments with serial number 2520G06295 and lower (2816A05450 and lower):

1. Make the following changes to the appropriate parts-lists:

Instrument In Table A-2 and Table A-5:

	Reference	Description	HP Part #
A0 08116	A3	BD AY-MICROPRCR	08116-66513

Microprocessor Board In Table A-5 *modify*:

	Reference	Description	HP Part #
A3 08116-66513	BT1	BAT NI-CAD	1420-0251
	U10	RAM	1818-1768

In Table A-5 *delete*:

	Reference	Description	HP Part #
A3 08116-66513	CR6		
	R24		
	U40		
	W3		

In Table A-5 add:

	Reference	Description	HP Part #
A3 08116-66513	C14	CAP .1 μ F CER 20%	0160-5746
	Q2	XSTR NPN 2N3904	1854-1028
	R7	RES 200 Ω .125 W 1%	0757-0407
	R8	RES 100K .125 W 1%	0757-0465
	R18	RES 1K .125 W 1%	0757-0280
	RT1	THMS 1K DIS	0837-0050
	U5	ROM B	1818-3103
	U6	ROM A	1818-3104
	U7	ROM 9	1818-3105
	U8	ROM 8	1818-3106
	U9	ROM 7	1818-3107
	U38	ROM 6	1818-3108
	U28	XSTR QUAD PNP	1858-0058
	W5	RES-ZERO OHMS	8159-0005

2. Figure B-11 shows the location of the ROMs on microprocessor board 66513, modify Figure 10.7-9 accordingly.

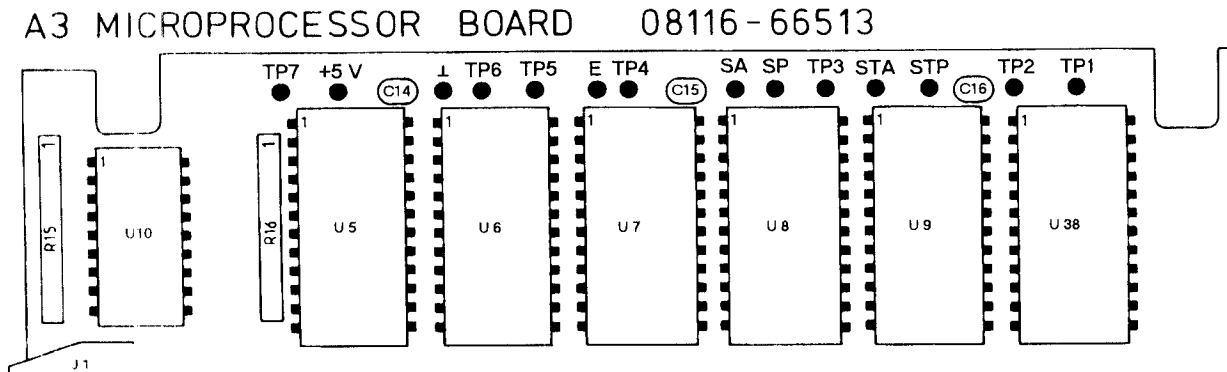

Figure B-11. 08116-66513: ROM layout

3. Figure B-12 shows the change to Figure 10.7-5 for addressing six ROMs.

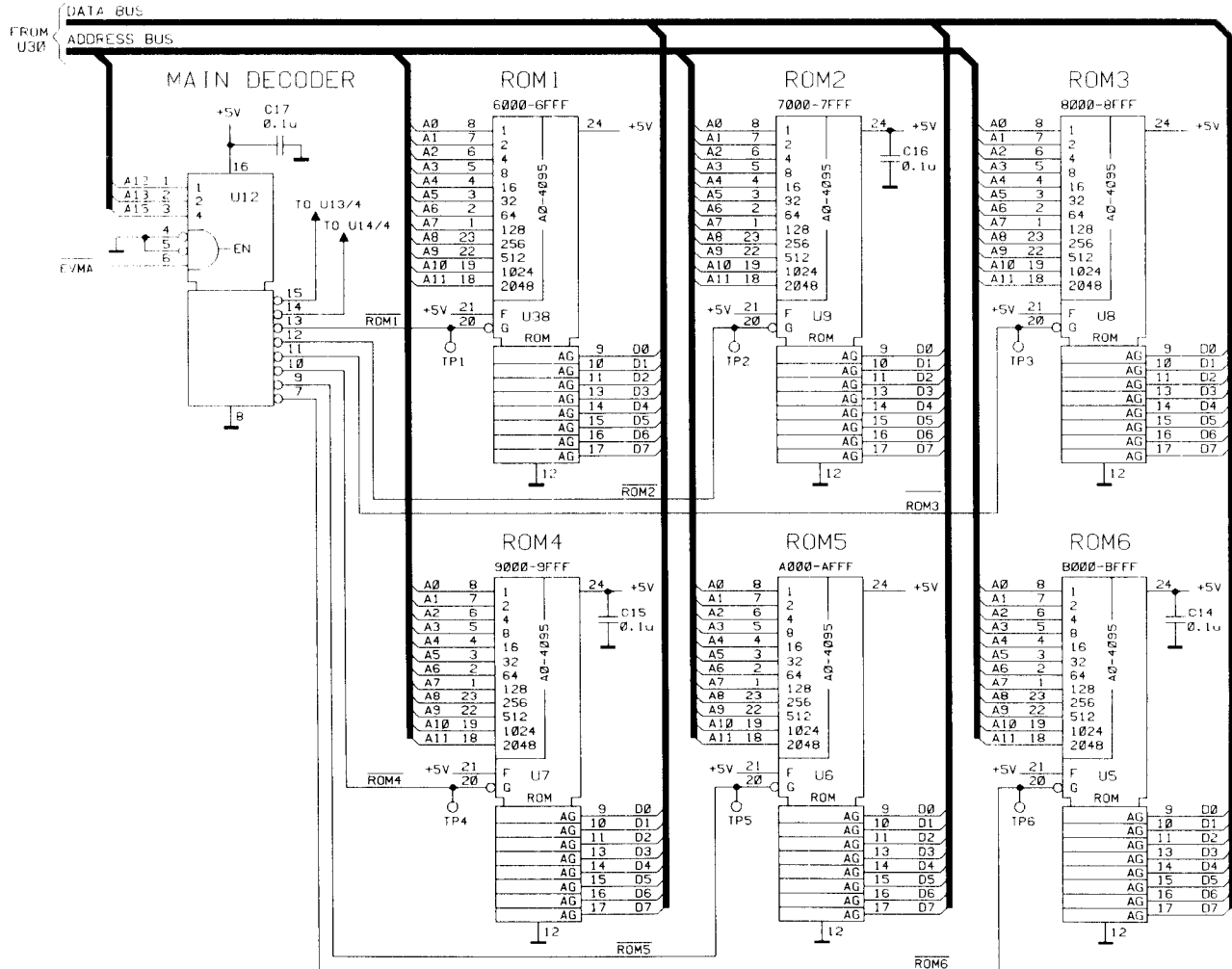

Figure B-12. 08116-66513: ROM schematic

4. Figure B-13 shows the location of U39 and R21 on microprocessor board 66513, modify Figure 10.7-9 accordingly.

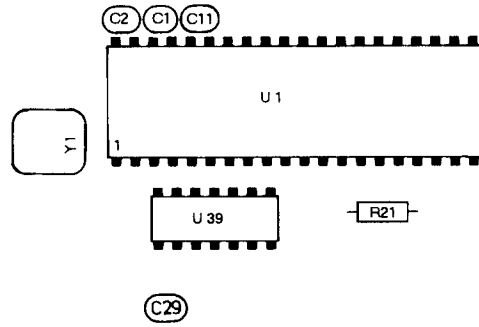

Figure B-13. 08116-66513: U39 and R21

5. Figure B-14 shows the location of U28 and other additional components, modify Figure 10.7-9 accordingly.

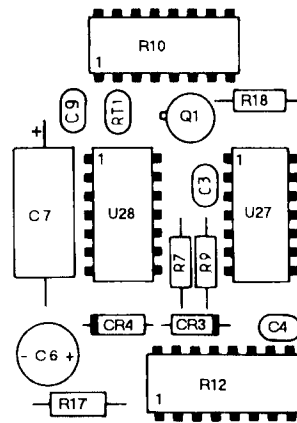

Figure B-14. 08116-66513: U28 layout

6. Figure B-15 shows the RAM battery supply circuit on microprocessor board 66513, modify Figure 10.7-5 accordingly.

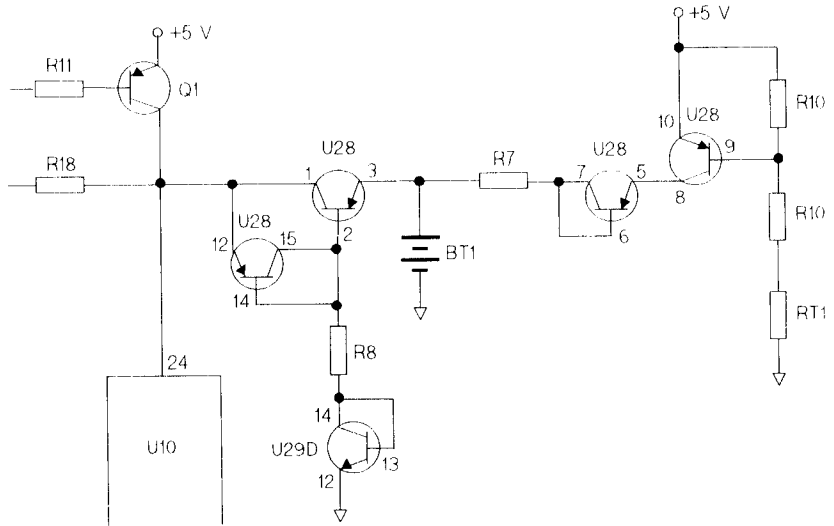

Figure B-15. 08116-66513: U28 schematic

7. Modify the schematic Figure 10.7-4 as shown in Figure B-16.

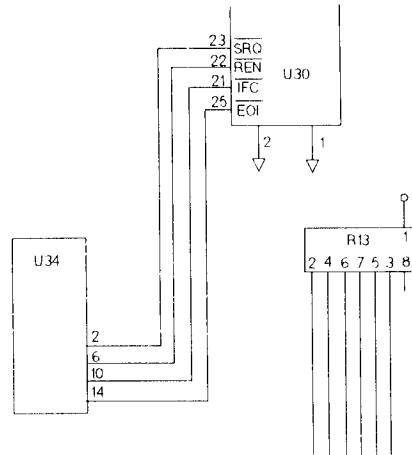

Figure B-16. 08116-66513: Deletion of W3

8. Figure B-17 shows the microprocessor reset circuit on microprocessor board 66513, modify the schematic Figure 10.7-5 accordingly.

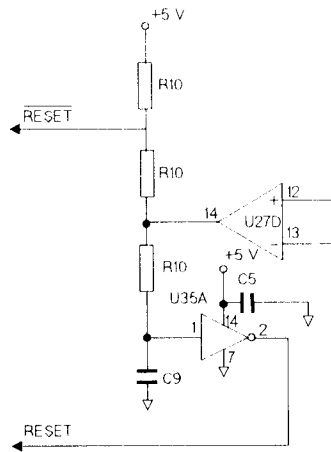

Figure B-17. 08116-66513: Reset circuit

9. In Chapter 10.7 modify the section on trouble-shooting the ROM as follows:

ROM The ROMs can be checked using signature analysis:

1. Set the microprocessor to free-run as described in “Free Running Signature Analysis” in Chapter 10.7 and connect the signature analyzer probes as given in Table 10.7-4.

**Table 10.7-4
Signature Analyzer Probe connections for ROM Test**

Probe	Trigger	Connect to
Start	\	See Table 10.7-5
Stop	/	See Table 10.7-5
Clock	\	TP “E”
Ground		Ground

2. Connect the data probe to the +5 V supply and check that the signature is P254. If not, the microprocessor is not free-running.

3. For each ROM in Table 10.7-5 connect the start and stop probes to the indicated test point and use the data probe to check the signature at the listed pins:

**Table 10.7-5 ROM signatures
08116-1002X/310X Series**

ROM:	U5	U6	U7	U8	U9	U38
Start/Stop:	TP6	TP5	TP4	TP3	TP2	TP1
Pin						
9	278A	P726	752H	1P19	HHU5	55FU
10	6A4H	PPAC	2537	AC35	001P	384F
11	4731	U658	6064	F764	FA3H	H52H
13	U9H8	H7A7	431U	9H70	936H	PH16
14	6344	CP5F	9415	61U7	64PA	6517
15	PCC0	9P52	1F93	3061	A738	01FC
16	8P11	A30C	0059	FH3C	PC47	P77H
17	9A08	H5UU	8H81	C0C9	C5CF	HCH4
24	P254	P254	P254	P254	P254	P254

Changing the ROM

If the ROMs are changed, the data saved in the RAM has to be made compatible with the new ROMs. This can be done by setting the HP 8116A to an error condition (E.WID and SINE waveform, for example) and turning the instrument off and on again.

If the instrument becomes totally inoperable switch it off and disconnect the RAM back-up battery for at least 30 seconds. This will destroy the stored RAM data. Re-connect the RAM back-up battery and switch the instrument on. The Standard Parameter Set is now loaded into the RAM.

Change 62

For instruments with serial number 2520G06395 and lower (2816A05450 and lower), make the following changes to the appropriate parts-lists:

Main Board

In Table A-3 *modify*:

	Reference	Description	HP Part #
A1 08116-66531	R441*	RES 26.1 Ω 1%	0698-3432

Change 63

For instruments with serial number 2520G06495 and lower (2816A05450 and lower), make the following changes to the appropriate parts-lists:

Main Board In Table A-3 *modify*:

	Reference	Description	HP Part #
A1 08116-66531	S1	SW-PB	3101-2091

Change 64

For instruments with serial number 2833G06945 and lower (2816A05450 and lower), make the following changes to the appropriate parts-lists:

Main Board In Table A-3 *modify*:

	Reference	Description	HP Part #
A1 08116-66531	C523,524	CAP 270 μ F 40 V	0180-2455
	C525*	CAP 10 pF	0160-3874
	C538*	CAP 1.5 pF 200 V	0160-4381
	C502	CAP 100 pF 200 V 5%	0160-5730
	C551	CAP 6.8 pF	0160-5738
	Q505	XSTR PNP	1853-0312
	Q506	XSTR NPN	1854-0784

In Table A-3 *delete*:

	Reference	Description	HP Part #
A1 08116-66531	C557*		
	W15,16		

In Table A-3 *add*:

	Reference	Description	HP Part #
A1 08116-66531	F1,2	FUSE 5 A 125 V	2110-0297
	MP500	XSTR HEATSINK 08116-04151	

Note



F1 replaces W15 and F2 replaces W16 in Figure 10.2-3 and Figure 10.4-8.

Change 65

For instruments with serial number 2901G07495 and lower (2816A05450 and lower):

1. Make the following changes to the appropriate parts-lists:

Instrument In Table A-2 *modify*:

	Reference	Description	HP Part #
A0 08116	MP17	COVER-BOTTOM	5001-0438
	MP18	COVER-TOP	08116-04103
	MP20	TRIM STRIP	5001-0438
	MP21	TRIM STRIP	5040-7203
	MP22	FOOT	5040-7201
	MP23	PNL REAR STD	5040-7221
	MP24	FOOT-REAR N-SKI	5040-7222
	B1	FAN-TBAX	3160-0266

In Table A-2 *add*:

	Reference	Description	HP Part #
A0 08116	B2	MOD MOTOR CON	3160-0310

Change 66

For instruments with serial number 2901G07545 and lower (2816A05450 and lower), make the following changes to the appropriate parts-lists:

Control Board In Table A-4 and Table A-9 *modify*:

	Reference	Description	HP Part #
A2 08116-66522	R24	RES-TRMR 500 Ω .5 W 10%	2100-0554
	R27	RES-TRMR 500 Ω .5 W 10%	2100-0554

Change 67

For instruments with serial number 2901G07595 and lower (2816A05450 and lower), make the following changes to the appropriate parts-lists:

Main Board In Table A-3 *modify*:

	Reference	Description	HP Part #
A1 08116-66531	R226	RES 2.05K 1%	0698-4431
	R227	RES-TRMR 500 Ω .5 W 10%	2100-0554

Change 68

For instruments with serial number 2901G07795 and lower (2816A05450 and lower), make the following changes to the appropriate parts-lists:

Microprocessor Board In Table A-5 *modify*:

	Reference	Description	HP Part #
A3 08116-66534	U17	IC 74F138	1820-2861

Change 69

For instruments with serial number 2901G07895 and lower (2816A05450 and lower), make the following changes to the appropriate parts-lists:

Main Board In Table A-3 *modify*:

	Reference	Description	HP Part #
A1 08116-66531	C230*	CAP 33 pF 200 V 5%	0160-4386
	C235*	CAP 39 pF 200 V 10%	0160-4494
	R422	RES 9.09K .125 W 1%	0757-0288

Change 70

For instruments with serial number 2901G08595 and lower, make the following changes to the appropriate parts-lists:

Main Board In Table A-3 *add*:

	Reference	Description	HP Part #
A1 08116-66531	C539	CAP 100 PF 5%	0160-5730

In Table A-3 *delete*:

	Reference	Description	HP Part #
A1 08116-66531	C553		

Change 71

For instruments with serial number 2901G08645 and lower, make the following changes to the appropriate parts-lists:

Main Board In Table A-3 *modify*:

	Reference	Description	HP Part #
A1 08116-66531	R157	RES 4.64 K	0698-3155
	R441	RES 14.7	0698-3428

Change 72

For instruments with serial number 2901G08720 and lower, make the following changes to the appropriate parts-lists:

Microprocessor Board In Table A-5 *modify*:

	Reference	Description	HP Part #
A3 08116-66534	U40	ROM 1	08116-10017

Change 73

For instruments with serial number 2901G10470 and lower:

1. Make the following changes to the appropriate parts-lists:

Main Board In Table A-3 *modify*:

	Reference	Description	HP Part #
A1 08116-66531	R401	RES-TRMR 100K 10%	2100-3214
A1 08116-66531	R402	RES-TRMR 100K 10%	2100-3214
A1 08116-66531	R403	RES-TRMR 100K 10%	2100-3214
A1 08116-66531	R407	RES-TRMR 1K 10%	2100-3211
A1 08116-66531	R425	RES-TRMR 2K 10%	2100-0567
A1 08116-66531	R445	RES-TRMR 100K 10%	2100-3214

Change 74

For instruments with serial number 2901G10770 and lower (A1 EDC label < A-3119):

1. Make the following changes to the appropriate parts-lists:

Main Board In Table A-3 *modify*:

	Reference	Description	HP Part #
A1 08116-66531	R219*	RES 9.09K 1% .12	0757-0288
A1 08116-66531	R222*	RES 9.09K 1% .12	0757-0288

In Table A-3 *delete*:

	Reference	Description	HP Part #
A1 08116-66531	R247	RES-TRMR 10K	0698-7260
A1 08116-66531	R248	RES-TRMR 10K	0698-7260
A1 08116-66531	CR201	DIO SCHOTTKY	1901-0535
A1 08116-66531	CR202	DIO SCHOTTKY	1901-0535

Change 75

For instruments with serial number 2901G11345 and lower (A1 EDC label < A-3127):

1. Make the following changes to the appropriate parts-lists:

Main Board In Table A-3 *modify*:

	Reference	Description	HP Part #
A1 08116-66531	C300*	CAP 15pF 200V	0160-4385

In Table A-3 *delete*:

	Reference	Description	HP Part #
A1 08116-66531	R20	RES 147 1%	0698-3438

Change 76

For instruments with serial number 3127G11520 and lower:

1. Make the following changes to the appropriate parts-lists:

Instrument In Table A-2 *modify*:

	Reference	Description	HP Part #
A0 08116	A1	BD AY-MAIN	08116-66531
	A3	BD AY-MICROPRCR	08116-66534
	MP8	FRAME REAR 2	5021-5814
	MP11	HEATSINK POWER	08112-21105
	MP14	KEEPER	08112-04154
	MP25	FUSEHOLDER BODY	2110-0564

In Table A-2 *add*:

	Reference	Description	HP Part #
A0 08116	A6	BD AY-HP1B	08116-66506
	MP5	BRACKET FAN	08112-04156
	MP6	BRACKET XFMR	08112-04153
	MP9	PANEL REAR	5061-2116
	MP10	HEATSINK REAR	08112-21101
	MP12	SIDE STRUT 1/2M	5021-5831
	MP13	SIDE STRUT 1/2M	5021-5831
	MP17	COVER BOTTOM	5001-1233
	MP18	COVER TOP	08116-04113
	MP23	FOOT REAR	5041-8821
	MP32	STDF-HEX .327-IN	0380-0644
	MP41	WSHR-LK INTL T	2190-0016
	MP61	WASHER, LOCK	2190-0074

In Table A-2 *delete*:

	Reference	Description	HP Part #
A0 08116	C1	CAP 0.047uF 0 V	0160-4323
	MP50	CHASSIS	08116-60101
	MP51	BRACKET-XFMR	08116-01203
	MP52	BRACKET-XFMR	08116-01201
	MP54	SCR-TPG 8-16	0624-0413
	MP55	COVER	08116-04123

Instrument (Option 001) In Table A-8 *add*:

	Reference	Description	HP Part #
A0 08116	MP9	PANEL REAR	08116-60254

Microprocessor Board In Table A-5 *modify*:

	Reference	Description	HP Part #
A3	08116-66534	08116-66534	
	C3	0160-5746	CAP 0.1uF 50 V
	C4	0160-5746	CAP 0.1uF 50 V
	C5	0160-5746	CAP 0.1uF 50 V
	C6	0180-2856	CAP 47uF 25 V
	C8	0180-2856	CAP 47uF 25 V
	C9	0160-5746	CAP 0.1uF 50 V
	C11	0160-5746	CAP 0.1uF 50 V
	C12	0160-5746	CAP 0.1uF 50 V
	C13	0160-5746	CAP 0.1uF 50 V
	C15	0160-5746	CAP 0.1uF 50 V
	C16	0160-5746	CAP 0.1uF 50 V
	C17	0160-5746	CAP 0.1uF 50 V
	C18	0160-5746	CAP 0.1uF 50 V
	C19	0160-5746	CAP 0.1uF 50 V
	C20	0160-5746	CAP 0.1uF 50 V
	C21	0160-5746	CAP 0.1uF 50 V
	C22	0160-5746	CAP 0.1uF 50 V
	C23	0160-5746	CAP 0.1uF 50 V
	C24	0160-5746	CAP 0.1uF 50 V
	C25	0160-5746	CAP 0.1uF 50 V
	C26	0160-5746	CAP 0.1uF 50 V
	C27	0160-5746	CAP 0.1uF 50 V
	C28	0160-5746	CAP 0.1uF 50 V
	C30	0160-5746	CAP 0.1uF 50 V
	C31	0160-5746	CAP 0.1uF 50 V
	C32	0160-5746	CAP 0.1uF 50 V
	C33	0160-5746	CAP 0.1uF 50 V
	C34	0160-5746	CAP 0.1uF 50 V
	C36	0160-5746	CAP 0.1uF 50 V
	J2	1251-8930	CONN-POST-TP-HDR
	R6	0757-0412	RES 365 1% .125W
	R12	1810-0316	NETWORK-RES DIP
	R13	1810-0206	NETWORK-RES SIP
	R22	0757-0442	RES 10K 1% .125W
	U40	08116-10018	ROM 1
	W1	1258-0124	SHUNT-PROGRAM
	W4	5180-2405	CBL RBN 350 MM

In Table A-5 *delete*:

	Reference	Description	HP Part #
A3 08116-66534	C10	CAP 0.1uF 50 V	0160-6623
	C14	CAP 0.1uF 50 V	0160-6623
	C37	CAP 0.1uF 50 V	0160-6623
	J4	CONN-POST-TP-HDR	1251-4670
	J5	CONN-POST-TP-HDR	1251-4672
	R25	RES 10K 1% .125W	0757-0442
	R26	RES 10K 1% .125W	0757-0442
	R27	RES 3.16K 1%	0757-0279

In Table A-5 *add*:

	Reference	Description	HP Part #
A3 08116-66534	R23	RES 301K 1% .125W	0757-0442
	TP8	TERM.-TEST POINT	0360-2264
	W3	RES-ZERO OHMS	8159-0005

Main Board In Table A-3 *modify*:

	Reference	Description	HP Part #
A1 08116-66531	MP1	HEAT SINK	08112-21104

In Table A-3 *add*:

	Reference	Description	HP Part #
A1 08116-66531	CR515	DIO-SWITCHING	1901-0050
	CR516	DIO-SWITCHING	1901-0050
	VR506	DIO-ZNR 1N5355B	1902-1340
	VR507	DIO-ZNR 1N5355B	1902-1340
	W12	RES-ZERO OHMS	8159-0005
	W13	RES-ZERO OHMS	8159-0005
	W14	RES-ZERO OHMS	8159-0005

In Table A-3 *delete*:

	Reference	Description	HP Part #
A1 08116-66531	CR20	CAP 1uF 50 V	0160-3508
	C21	CAP 0.01uF 100V	0160-3879
	CR10	DIO-SWITCHING	1901-0050
	CR11	DIO-SWITCHING	1901-0050
	CR12	DIO-SWITCHING	1901-0050
	R30	RES 20K 1% .125W	0757-0449
	R31	RES 20K 1% .125W	0757-0449
	R32	RES 20K 1% .125W	0757-0449
	R33	RES 20K 1% .125W	0757-0449
	R34	RES 215K 1%	0698-3454
	R35	RES 2 1% 3W PWI	0811-2455
	R36	RES 2 1% 3W PWI	0811-2455
	R37	RES 5.11K 1%	0757-0438
	R38	RES 215K 1%	0698-3454
	R39	RES 147K 1%	0698-3452
	R40	RES 31.6K 1%	0698-3160
	R41	RES 5.11K 1%	0757-0438
	R42	RES 5.11K 1%	0757-0438
	R43	RES 31.6K 1%	0698-3160
	R44	RES 31.6K 1%	0698-3160
	R45	RES 100K 1%	0757-0465
	R46	RES 10K 1% .125W	0757-0442
	R47	RES 147K 1%	0698-3452
	R48	RES 100K 1%	0757-0465
	VR2	DIO-ZNR 1N937	1902-0786
	VR3	DIO-ZNR 4.3V 5%	1902-0949
	Q7	XSTR	1854-1028
	Q8	XSTR	1853-0563
	U7	IC OP-07C	1826-0635

2. Add the following figure to the section "Instruments Covered by This Manual" in Chapter 1:



Figure B-18. Serial Number Plate (US)

3. In the section "General" in Chapter 10, correct the last sentence to read:

The **six** board assemblies contained in the HP 8116A are listed in Table 10-1 which lists the servicing chapters applicable to each board.

4. Add the following line to Table 10-1 in Chapter 10:

HP-IB Connector Board	A6	10.7
-----------------------	----	------

5. In the section “Troubleshooting” in Chapter 10.1, delete the following note:

Note



Flashing of the frontpanel lamps indicates a fault related to the ± 24 V supplies. Refer to ± 24 V supplies in Chapter 10.2.

6. In the section “Preparing the HP 8116A for servicing” in Chapter 10.1, replace the procedure with the following text:
 1. Remove all four feet at the rear of the instrument by unscrewing the fastening screws.
 2. Remove the single screw holding the instrument’s top cover to the rear panel.
 3. Remove the cover by sliding it backwards.
 4. Remove the four screws securing the microprocessor board.
 5. Lift the microprocessor board and stand it vertically by placing the cut-outs on the edge of the board over the locating lugs on the inside of the right-hand side-panel (as seen from the front of the instrument).
 6. Remove the screen covering the control board.
 7. Lift the control board and stand it vertically by placing the cut-outs on the edge of the board over the locating lugs on the inside of the left-hand side-panel (as seen from the front of the instrument).
7. Replace Figure 10.2-1 in Chapter 10.2 with the following figure:

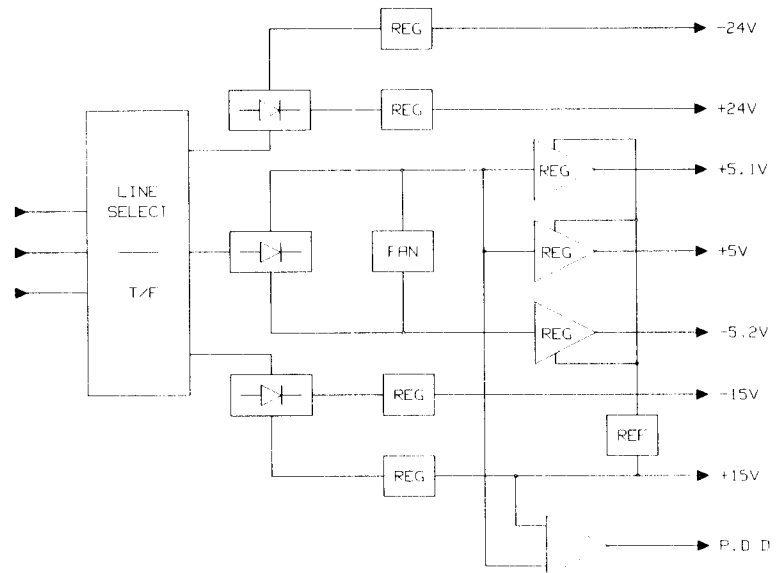

Figure B-19. Power Supply block diagram

8. In the section “Voltage and Current Sensing Circuits” in Chapter 10.2 delete the sub-section heading “ ± 24 V supplies” and the following text:

If the current drawn through R35/R36 becomes excessive, the normally negative output of U7A switches towards the positive supply. C20 then charges through R37 until the threshold of the Schmitt trigger U7B is reached. The output of U7B goes negative, switching on Q8 which withdraws the -24 V output of U4. Similarly, the output of U7C goes positive, switching on Q7 which withdraws the +24 V output of U3. In addition, the output of U7D goes positive for approximately 1 ms and a Power Down Detected signal is generated.

The Power Down Detected signal resets the microprocessor, however when the ± 24 V supplies are withdrawn the excessive current in R35/36 is removed and the current-sensing circuits re-enable the supplies. The microprocessor restarts and runs the instrument self-test, beginning with the frontpanel lamp-test, until the current becomes excessive again.

This cycle repeats continuously and therefore the frontpanel lamps flash, as the self-test is never completed before the microprocessor resets again. Refer to the Troubleshooting part of this chapter for more information.

9. Delete the following text from the section “Power-down Detection” in Chapter 10.2:

The Power Down Detected signal is also generated by the ± 24 V supply current-sensing circuits, as described in “ ± 24 V supplies” in Chapter 10.2 above.

10. In “Troubleshooting the Power Supply” in Chapter 10.2 delete the sub-sections “Removing the Fan”, “Re-fitting the Fan”, and “ ± 24 V supplies”. Replace these sections with the following:

Starting with the instrument in its servicing position (as described in “Preparing the HP 8116A for servicing” in Chapter 10.1) and referring to Figure B-20:

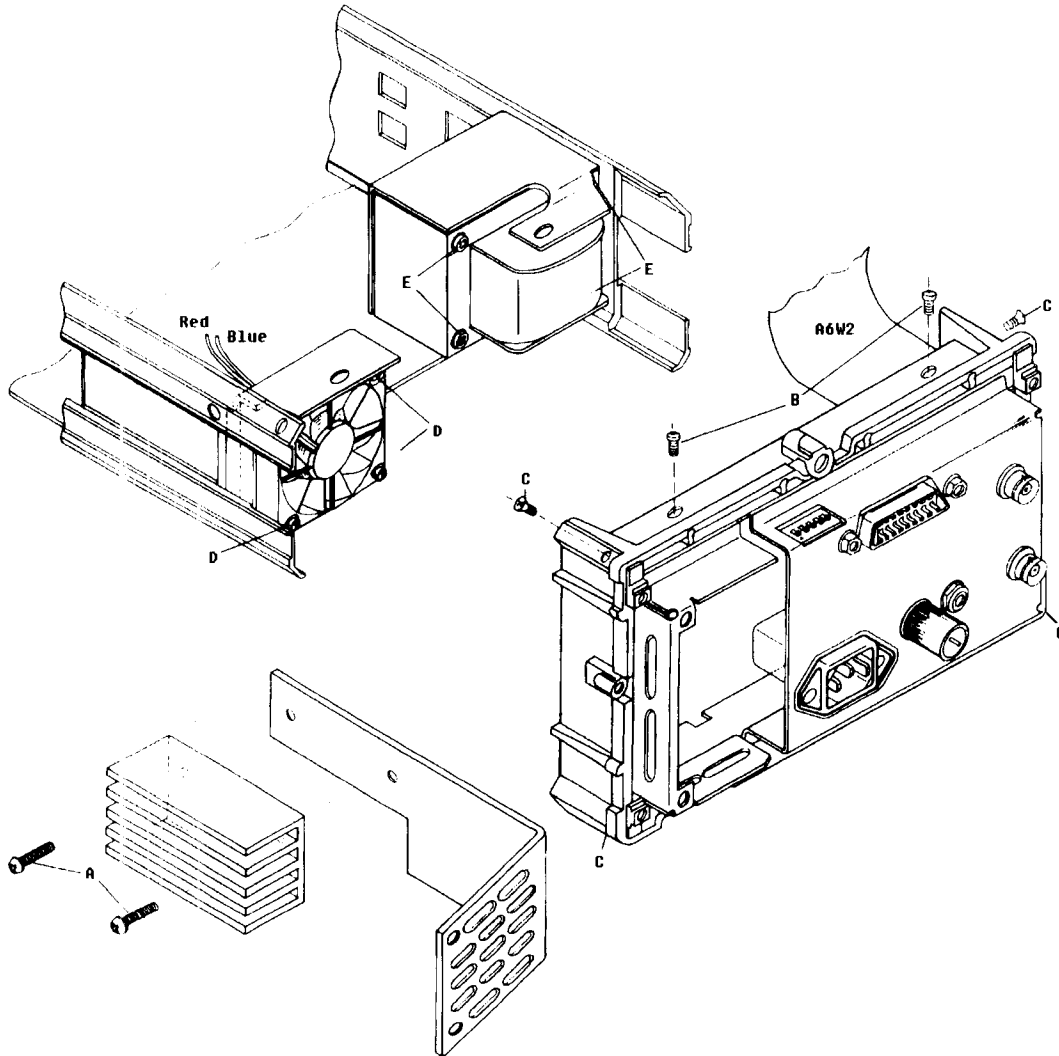

Figure B-20. Exploded view of HP 8116A rear frame

1. Turn off the instrument and disconnect the power cord.
2. Disconnect and remove the microprocessor board A3 and the control board A2 (Note which cables connect to which connectors/pins in order to make re-assembly simple).
3. Remove the bottom cover from the instrument.

Remove the heatsink, located in front of the fan, by unscrewing the two screws A.

4. Remove the two screws B, holding the rear frame to the brackets.
5. Remove the four screws C, holding the rear frame to the side frames.
6. Remove the rear frame by pulling it gently backwards.

If necessary, the fan can be removed by unscrewing screws D. Similarly, the transformer can be removed by unscrewing screws E.

11. Delete the following text from the section “Switching On” in Chapter 4:

If the frontpanel LEDs continue to flash, the instrument power supply is overloaded, refer to “±24 V supplies” in Chapter 10.2.

12. In the section “Rear Panel” in Chapter 4, delete Figure 4-14 and the section “HP-IB Connector”. Replace them with the following figure and text:

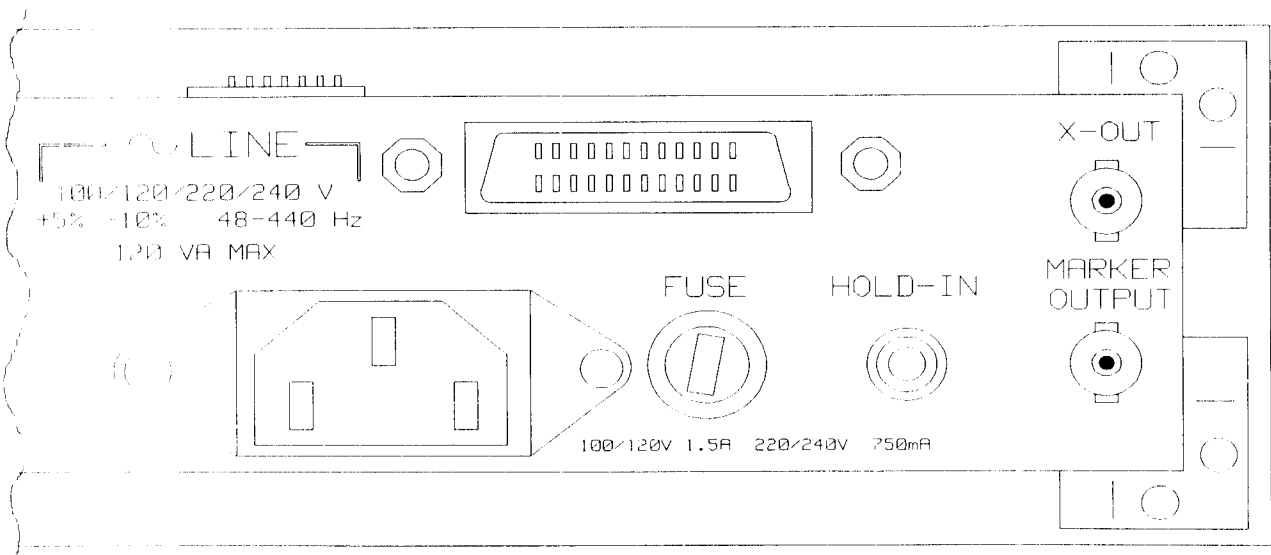

Figure B-21. Rear panel

When the instrument is switched on it determines its HP-IB address from the address switches on the rear panel. The address switches are preset at the factory to 16 decimal:



Figure B-22. HP-IB Address Switch (Factory setting)

To change the address, change the bit settings on the rear panel switch, then press the **LCL** key or switch the instrument off and on again.

Pressing the **LCL** key will display the current HP-IB address in decimal on the front panel digital display.

HP-IB Connector

Refer to Figure 3-3 for a definition of the HP-IB connector pins.

13. Delete the text in the section “Setting the HP-IB Address” in Chapter 6, and replace it with the following text:

The HP 8116A’s HP-IB address is read from the address switch on the rear panel when the instrument is switched on. The address switch is set at the factory to 16 decimal.

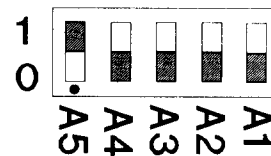

Figure B-23. HP-IB Address Switch (Factory setting)

Note



- Pressing the **LCL** key displays the current address while the key is depressed.
- When allocating addresses ensure that no two instruments on the bus have the same address.

To change the instrument’s address:

1. Change the address on the rear-panel address-switch.
 2. Press the **LCL** key or switch the instrument off and on again.
14. In Chapter 10.2 make the following change to the schematic diagram for the Main Board A1, Figure 10.2-2 as follows:
Delete the capacitor C1 (0.047 μ F) from the outputs of the line filter.
 15. Delete the following components, involved in ± 24 V power-down detection, from the Main Board schematic diagram, Figure 10.2-3:
 - CR10,CR11
 - C20,C21
 - Q7
 - R30,R31,R32,R33,R34,R35,R36,R37,R38,R39,
R40,R41,R42,R43,R44,R45,R46,R47
 - U7A/B/C/D
 - VR2

16. In Chapter 10.7 replace the component location diagram for the Microprocessor Board, Figure 10.7-9, with the following:

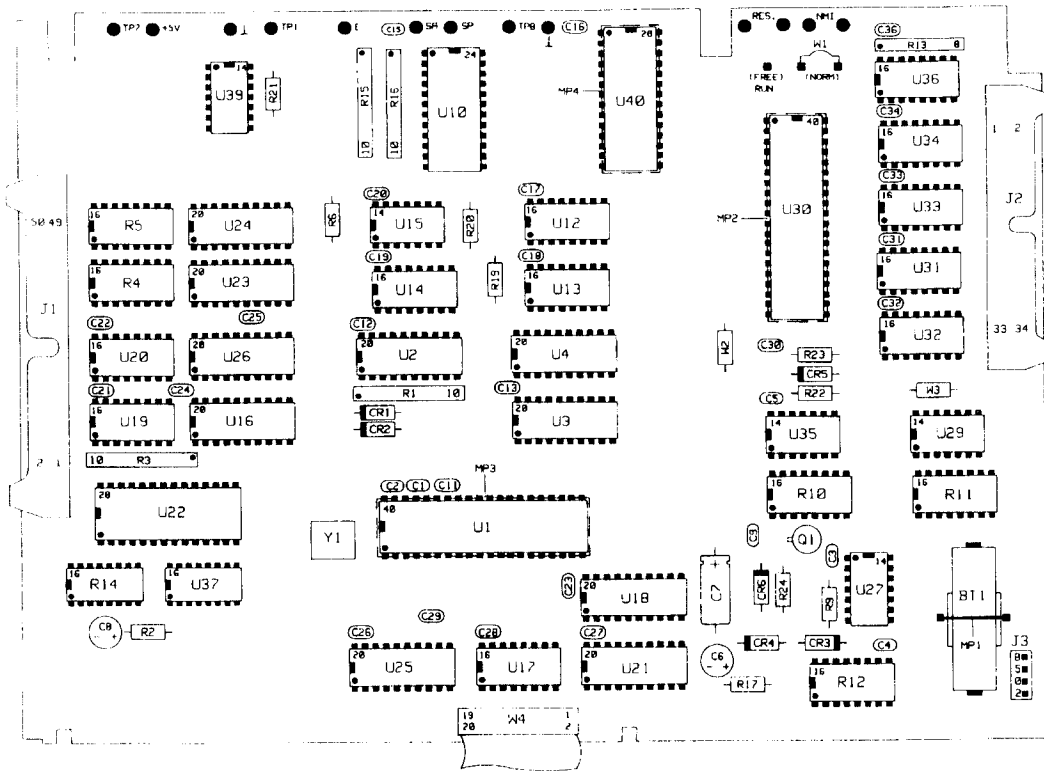

Figure B-24. Microprocessor Board A3 Component Layout and Locator

17. In Appendix A delete Figure A-1 and Figure A-2 and add the following two figures:

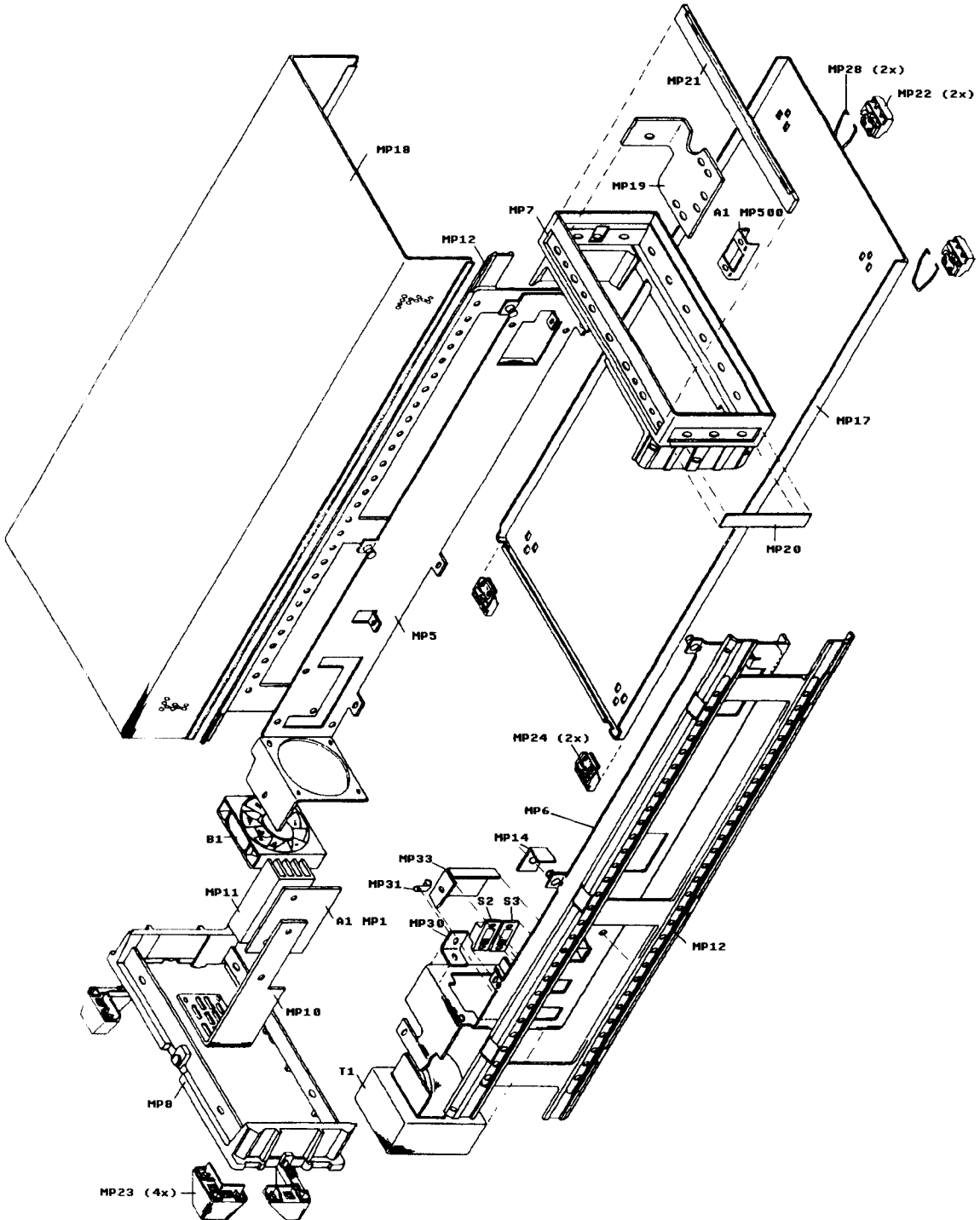

Figure B-25. Mechanical Parts - 1

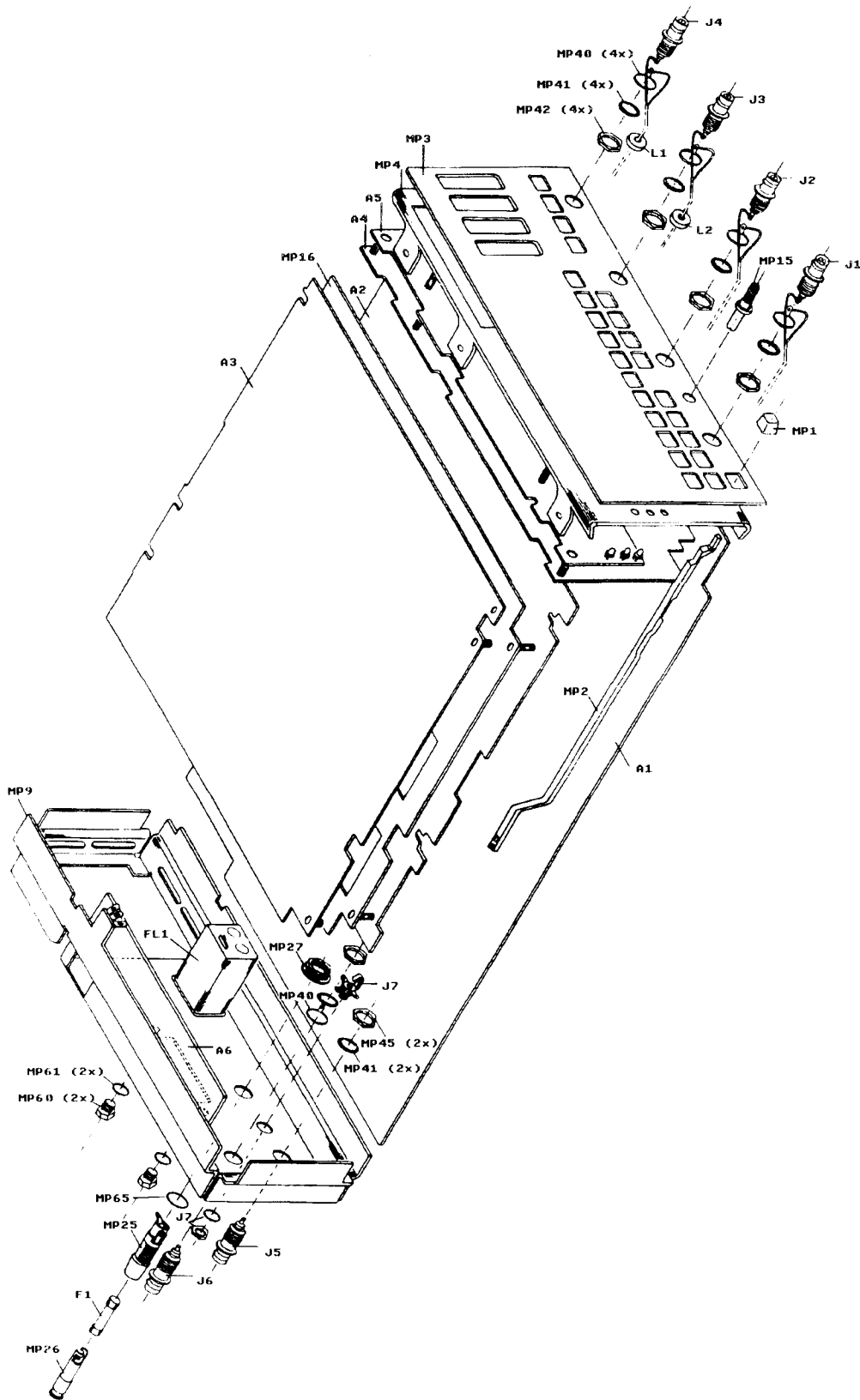

Figure B-26. Mechanical Parts - 2

Updating

Introduction

This appendix contains information to correct errors in the manual, and to update the manual for instruments with a serial number *higher* than that shown on the title page.

Sales and Service Offices

Information

Hewlett-Packard products are sold and supported worldwide through local HP Offices.

To contact the closest sales and service office, check your telephone directory, or contact one of the Headquarters listed below.

Asia

Hewlett-Packard Asia Ltd.
22/F, Bond Center
West Tower, 89 Queensway, Central, **Hong Kong**
G.P.O. Box 863, Hong Kong
Telephone: 5-848 7777, Telex: 76793 HPA HX, Cable: HPASIAL TD

Canada

Hewlett-Packard (Canada) Ltd.
6877 Goreway Drive, **Mississauga**, Ontario L4V 1M8, Canada
Telephone: (416) 678-9430, Telex: 069-8644, Fax: (416) 678-9421

Eastern Europe

Hewlett-Packard Ges.m.b.H
Lieblgasse 1
P.O. Box 72, A-1222 **Vienna**, Austria
Telephone: (222) 2500-0, Telex: 13 4425 HEPA A

Northern Europe

Hewlett-Packard S.A.
V.D. Hooplaan 241
P.O. Box 999, NL-118 LN 15 **Amstelveen**, The Netherlands
Telephone: 20 547 9999, Telex: 189 19 hpner

South East Europe

Hewlett-Packard S.A.
World Trade Center
110 Avenue Louis-Casai, 1215 Cointrin **Geneva**, Switzerland
Telephone: (022) 98 96 51, Telex: 27225 hpser
Mail Address:
P.O. Box CH-1217 Meyrin 1, **Geneva**, Switzerland

**Middle East and Central
Africa**

Hewlett-Packard S.A.
International Sales Branch
Middle East/Central Africa Sales H.Q.
7, Rue du Bois-du-Lan
P.O. Box 364, CH-1217 Meyrin 1, Geneva, Switzerland
Telephone: (022) 83 12 12, Telex: 27835 hmea, Cable:
HEWPACKSA Geneve, Fax: 783 7535

European Operations
Hewlett-Packard S.A.
150, Route du Nante d'Avril
CH-1217 Meyrin 2 Geneva, Switzerland
Telephone: (41/22) 780.8111, Fax: 780 8542

United Kingdom

Hewlett-Packard Ltd.
Nine Mile Ride, Wokingham, Berkshire, RG11 3LL
Telephone: 0344 773 100, Telex: 848805, Fax: (44/344) 763526

**United States of
America**

Customer Information Center
(800) 752-0900
6.00AM to 5PM Pacific Time

Eastern USA

Hewlett-Packard Co.
4 Choke Cherry Road, Rockville, MD 20850
Telephone: (301) 670-4300

Midwestern USA

Hewlett-Packard Co.
5201 Tollview Drive, Rolling Meadows, IL 60008
Telephone (312) 255-9800

Southern USA

Hewlett-Packard Co.
2015 South Park Place, Atlanta, GA 30339
Telephone: (404) 955-1500

Western USA

Hewlett-Packard Co.
5161 Lankershim Boulevard, North Hollywood, CA 91601
Telephone: (818) 505-5600

**Other International
Areas**

Hewlett-Packard Co.
Intercontinental Headquarters
3495 Deer Creek Road, Palo Alto, CA 94304
Telephone: (415) 857-5027, Telex: 034-8300, Cable: HEWPACK

Hewlett-Packard Trading S.A.
Bureau de Liaison/Bureau de Support
Ville des Lions, 9, Hai Galloul. **DZ-BORDJ EL BAHRI**
Telephone: 76 02 07, Fax: 281 0387

Index

- A**
 - A0 - A1, 6-8
 - Accessories, 1-3
 - AC line voltage, 3-2
 - Adjustment, 9-1
 - AM, 4-8
 - AMP, 4-12, 6-6
 - Autovernier
 - Operating, 4-14
 - Programming, 6-8
 - Status, 6-16

- B**
 - BUR, 4-12, 6-7

- C**
 - C0 - C1, 6-10
 - Calibration, 9-1
 - Connector
 - HP-IB, 3-5
 - Control Input, 2-10
 - Control mode, 2-8
 - AM, 4-8
 - FM, 4-8
 - Programming, 6-5
 - PWM, 4-9
 - Selecting, 4-7
 - VCO, 4-10
 - CST, 6-11
 - CT0 - CT4, 6-5

- D**
 - D0 - D1, 6-10
 - DCL, 6-17
 - Dimensions, 2-13
 - DTY, 4-12, 6-6
 - Duty cycle
 - Specification, 2-2

E E01, 10.1-5
E11, 10.1-5
E21, 10.1-5
E31, 10.1-5
E41, 10.1-7
E42, 10.1-7
E51, 10.1-7
E52, 10.1-7
E53, 10.1-7
E54, 10.1-7
E55, 10.1-9
E56, 10.1-9
E57, 10.1-9
E58, 10.1-9
E59, 10.1-11
E60, 10.1-11
E62, 10.1-11
Environmental characteristics, 2-13
Error
 Programming, 6-15
 reporting, 6-13
 Syntax, 6-15
 Timing, 6-14
External Input, 2-10
External Trigger Controls, 4-6

F Fault
 0, 10.1-5
 E01, 10.1-5
 E11, 10.1-5
 E21, 10.1-5
 E31, 10.1-5
 E41, 10.1-7
 E42, 10.1-7
 E51, 10.1-7
 E52, 10.1-7
 E53, 10.1-7
 E54, 10.1-7
 E55, 10.1-9
 E56, 10.1-9
 E57, 10.1-9
 E58, 10.1-9
 E59, 10.1-11
 E60, 10.1-11
 E61, 10.1-11
 E62, 10.1-11
Fault reporting, 6-13, 10.1-3
FM, 4-8
Frequency
 Specification, 2-2
FRQ, 4-12, 6-6

- G** General characteristics, 2-13
 - GET, 6-17
 - GTL, 6-17

- H** H0 - H1, 6-5
 - HIL, 4-12, 6-6
 - Hold Input, 2-10, 4-16
 - HP-IB, 2-12
 - Address, 6-1
 - connector, 3-5
 - logic levels, 3-5
 - Status byte, 6-13
 - Universal commands, 6-17

- I** IERR, 6-13, 6-14, 6-15
 - Inputs, 2-10
 - Inspection, 3-1
 - Installation, 3-1

- K** Keys
 - 1 CYCLE, 4-6
 - 90°, 4-11
 - AUTO, 4-14
 - COMPL, 4-15
 - DISABLE, 4-15
 - LCL, 6-2
 - LIMIT, 4-15
 - MAN, 4-6
 - VERNIER, 4-13

- L** L0 - L1, 6-10
 - LD, 6-8
 - LLO, 6-17
 - Local lockout, 6-2
 - Local mode, 6-2
 - LOL, 4-12, 6-6
 - LU, 6-8

- M** M1 - M8, 6-4
 - Marker Output, 2-11, 4-16
 - MD, 6-8
 - MRK, 4-12, 6-7
 - MU, 6-8

- O**
 - OFS, 4-12, 6-6
 - Operating, 4-1
 - Operating characteristics, 2-6
 - Options, 1-2
 - Output, 2-10
 - Specification, 2-4
 - Output Amplifier, 10.4-3
 - Output mode
 - Programming, 6-10
 - Selecting, 4-15
 - Outputs, 2-10

- P**
 - Parameter
 - Programming, 6-6
 - Reading, 6-9, 6-11
 - Setting, 4-12
 - Performance Tests, 8-1
 - Power
 - cable, 3-3
 - requirements, 3-2
 - Requirements, 2-13
 - Power on, 4-2
 - Power Supply, 10.2-1
 - Programming, 6-1
 - Examples, 7-1
 - Programming error, 6-15
 - Pulse width
 - Specification, 2-3
 - PWM, 4-9

- R**
 - Recalibration, 2-13, 9-1
 - Remote mode, 6-2
 - Replaceable Parts
 - Control Board A2 (Option 001), A-41
 - Control Board A2 (Standard), A-27
 - Display Board A5 (Option 001), A-51
 - Display Board A5 (Standard), A-38
 - Instrument (Option 001), A-40
 - Instrument (Standard), A-5
 - Keyboard A4 (Option 001), A-48
 - Keyboard A4 (Standard), A-36
 - Main Board A1, A-7
 - Microprocessor Board A3, A-32
 - RPT, 4-12, 6-7

- S**
 - SD, 6-8
 - SDC, 6-17
 - Servicing, 10-1
 - Control Board, 10.5-1
 - Control Input, 10.3-2
 - Display, 10.7-5
 - Introduction, 10-1
 - Keyboard, 10.7-5
 - Microprocessor, 10.7-1
 - Option 001, 10.6-1
 - Output Amplifier, 10.4-1
 - Overview, 10.1-1
 - Power Supply, 10.2-1
 - Self-test, 10.1-3
 - Shaper, 10.4-1
 - Trigger Input, 10.3-1
 - VCO, 10.3-1
 - Width Generator, 10.3-1
 - Servicing position, 10.1-3
 - Shaper IC, 10.1-1, 10.4-1
 - Signature Analysis, 10.7-17
 - Slope Generator IC, 10.1-1
 - Slope IC, 10.3-3
 - SPD, 6-17
 - SPE, 6-17
 - Specifications, 2-1
 - SRQ, 6-13, 6-16
 - STA, 4-12, 6-7
 - Standard Parameter Set, 4-3
 - Status byte, 6-13
 - Status reporting, 6-13
 - STP, 4-12, 6-7
 - SU, 6-8
 - Switching on, 4-2
 - SWT, 4-12, 6-7
 - Syntax error, 6-15
 - System Failure, 6-15

- T**
 - T1 - T3, 6-4
 - Test
 - Recommended test equipment, 1-3
 - Self-test, 4-2, 6-15, 10.1-3
 - Testing
 - Self-test, 7-4
 - Timing error, 6-14
 - Timing IC, 10.1-1, 10.3-5
 - Trigger Controls, 4-6
 - Trigger mode, 2-6
 - Programming, 6-4
 - Selecting, 4-4
 - Trigger Output, 2-10, 4-6
 - Troubleshooting, 10.1-3
 - Control Board, 10.5-13
 - Keyboard, 10.7-19

- Microprocessor, 10.7-17
- Option 001, 10.6-7
- Output Amplifier, 10.4-13
- Power Supply, 10.2-9
- Shaper, 10.4-11
- Trigger Input, 10.3-13
- VCO, 10.3-13
- Width Generator, 10.3-16

U UNL, 6-17
UNT, 6-17

V VCO, 4-10
VCO IC, 10.1-1, 10.3-3
Verification Tests, 8-1

W W0 - W4, 6-5
Waveform
 programming, 6-5
 selecting, 4-11
Waveforms
 Specifications, 2-5
Weight, 2-13
WID, 4-12, 6-6

X X-Output, 2-11, 4-16

8116A-07A

S E R V I C E N O T E

SUPERSEDES: 8116A-07

HP 8116A Pulse/Function Generator 50 MHz

Serial Numbers: 0000A00000 / 2901G11520

Solving EOI Problems

To Be Performed By: HP-Qualified Personnel

Situation:

Some customers have indicated that the HP-IB hangs up/front panel locks up when the HP 8116A is under HP-IB control and the used terminators are 'CRLF' and 'EOI'. The instrument is designed to operate with messages terminated by 'CRLF' or 'END'!

Solution/Action:

Use correct terminator and/or hardware change.

A) Correct terminator

It is recommended to use 'CRLF' as terminator! This is easily accomplished as HP Basic normally terminates a message with 'CRLF' (the default end-of-line sequence) only, e.g.:

OUTPUT 716;B\$ Outputs a string followed by 'CRLF'. The
'EOI' line is not pulled.

Continued

DATE: 11 August 1992

ADMINISTRATIVE INFORMATION

SERVICE NOTE CLASSIFICATION:		
MODIFICATION AVAILABLE		
ACTION CATEGORY:	AGREEABLE TIME	<input checked="" type="checkbox"/> PERFORMANCE ENHANCEMENT <input type="checkbox"/> SERVICE/RELIABILITY ENHANCEMENT
LOCATION CATEGORY:	<input type="checkbox"/> CUSTOMER INSTALLABLE <input type="checkbox"/> ON-SITE <input checked="" type="checkbox"/> HP LOCATION	AVAILABLE UNTIL:
AUTHOR: PW	ENTITY: B1000	ADDITIONAL INFORMATION:

© 1992 HEWLETT-PACKARD COMPANY
PRINTED IN U.S.A.



However, if 'EOI' (end-or-identify) is to be used instead of 'CRLF', the statement should be followed by 'END', e.g.:

OUTPUT 716;B\$ END Pulls the 'EOI' line during the last character B\$, suppresses 'CRLF'.

Caution

Boards are sensitive to electrostatic discharge (ESD). Please use standard ESD precautions whenever the unit's covers are removed!

- B) Hardware change Users of some non-HP versions of Basic may experience difficulty in terminating with 'CRLF' alone, 'EOI' cannot (easily) be turned off. If this is so, hardware changes have to be done.

The following is a summation of the steps necessary depending of the instruments serial number.

1. With the instrument switched OFF, unscrew and remove the four rear frame feet of the instrument.
2. Unscrew and remove the cover top (MP18).

Instruments with serial number 0000G00000 to 2520G05070, and instruments with serial number 0000A00000 to 2537Axxxxx

3. Take the CPU Board A3 out of the instrument. Cut the track from U34 pin 14 to U30 pin 25 (component side of A3). Solder a pull-up resistor (10K, 0757-0442) on the non-component side between U30 pin 25 and pin 20 (+5V).

Instruments with serial number 2632G05071 to 2632G06295, and instruments with serial number 2708Axxxxx to 2816Axxxxx

3. These instruments have the 'EOI' line cut and a 10 k pull-up resistor between pin 25 and pin 20 of U30.

If customers need the 'EOI' line reconnected:

Delete A3R23, R-FXD 10K, from U30 pin 25 to pin 20 (+5V). Connect U34 pin 14 to U30 pin 25. Connect U34 pin 13 to A3J2 pin 25.

Instruments with serial number 2752G06296 to 2901G11520, and instruments with serial number 2816Axxxxx to 3001Axxxxx

3. Transfer the Jumper A3W3 (rear center of A3) from the factory-setting position "EOI" to position "3".
4. Reassemble the cover top and the rear frame feet.
5. Run the Performance Tests.

MANUAL CHANGES **April, 98**

Manual for Model Number	8116A
Manual printed on	September 1993
	E0993
Manual Part Number	08116-90014

Make all ERRATA corrections.

Check the following table for your instrument serial prefix/serial number/EDC and make the listed changes to your manual

New Item

Serial Prefix or Serial Number	Manual Changes
-----------------------------------	-------------------

ERRATA

3134G11546	1
3134G12596	2
3134G12746	3
3134G12896	4
3134G13446	5
3134G15496	6
3134G15771	7
3134G17821	8

MODEL 8116A

INDEX OF MANUAL CHANGES

MANUAL CHANGE ERRATA	FRAME	A1	A2	A3	A4	A5	
1		R20 C300* R436* U300					
2	MP60 W1	C407,531 C555 R228					
3		C18,19 C102,105 C110,213 C226,227 C240,402 C404,503 C504,507 C508,519- C522					
4.				U40			
5.				J3,W3			
6.				U10			
7.		C217*					
8						DS4,18,8 DS5,6,7,2, DS3,4	

MODEL 8116A

ERRATA

On Page A-21, change the Table of Replaceable Parts to read:

A1	R407	0100-3296	R-VAR 1K 10%
A1	R425	2100-3091	R-VAR 2K 10%

On Page 10.4-7, Schematic (1F), change to read:

R407 1K / R425 2K

On Page A-18, change the Table of Replaceable Parts to read:

A1	R219*,222*	0757-3519	R-FXD 12,4K
ADD:	R247*,248*	0698-7260	R-FXD 10,0K

On Page A-11 add:

A1	*,202*	1901-0535	DIO SCHOTTKY
----	--------	-----------	--------------

ANODE CR201 IS CONNECTED TO R247; CATHODE CR201 IS CONNECTED TO THE CONNECTION POINT OF R221 AND R219; THE OTHER END OF R248 IS CONNECTED TO CONNECTION POINT OF R219 AND R220. (BACKLOADED IN PARALLEL TO R219).

CATHODE CR202 IS CONNECTED TO R248; ANODE CR202 IS CONNECTED TO THE CONNECTION POINT OF R224 AND R222; THE OTHER END OF R248 IS CONNECTED TO CONNECTION POINT OF R222 AND R223. (BACKLOADED IN PARALLEL TO R222).

ON THE SECOND PAGE OF MANUAL CHANGE INSTRUMENT SERIAL NUMBER TO:

3134G11521 !

On Page A-34/35, Replaceable Parts List, change to read:

A3	U10	1LJ6-0001	IC RAM 2K
add A3	U40	08116-90020	EPROM

page after the front page:

SERIAL NUMBERS

Change to read:

This manual applies directly to instrument serial numbers

3134G11521....

page 1-1. Introduction

Instruments Covered by This Manual

Figure 1-1: Serial Number Plate

Change to read:

3134G11521

page 1-3. Introduction

Accessories

Change to read:

>>> see next page <<<

MODEL 8116A

Item	HP Part Number	Description
Carrying handle	5062-4001	Bail Handle Kit
Rack mounting a single unit	5062-3972	Rack Mounting Flange and Filler Panel Kit
Rack mounting a single unit on a shelf	5062-3996 +5062-4022 +08116-68703	Support Shelf Filler Panel Special Mounting Kit
Rack slide mounting of a single unit	5062-3996 +5062-4022 +1494-0015 +08116-68703	Support Shelf Filter Panel Rack Slide Kit Special Mounting Kit
Rack mounting of two units side by side	5062-3974 +5061-9694	Rack Flange Kit Lock Link Kit
Rack mounting of two units side by side on a shelf	5062-3996 +2x 08116-68703	Support Shelf Special Mounting Kit
Rack slide mounting of two units side by side	5062-3996 +1494-0015 +2x 08116-68703	Support Shelf Rack Slide Kit Special Mounting Kit
Linking with an HP 8116A, s/n 3127G11520 and lower, or all "A" s/n, a special linking kit is required	08116-68704	Special Linking Kit

page 1-4 Introduction

Table 1-1: Recommended Test Equipment

Instrument Counter Change	Recommended HP 5335A	Required 50 MHz, Start/Stop	Alternative HP 5334A/B	Use P,A
	HP 5370B	TI A -> B	HP 5370A	P,A
Change Digital Multimeter	HP 3458A	HP 3478A	...
	HP 5335A	50 MHz, Start/Stop	HP 5334A/B	P,A
Add Pulse Generator	HP 8112A	50 Mhz, variable width	HP 8161A	
Delete Attenuator	HP 33340C	20 dB, 2 W		

page 10.5-9, Schematic 2B

Figure 10.5-6:

Change to read:

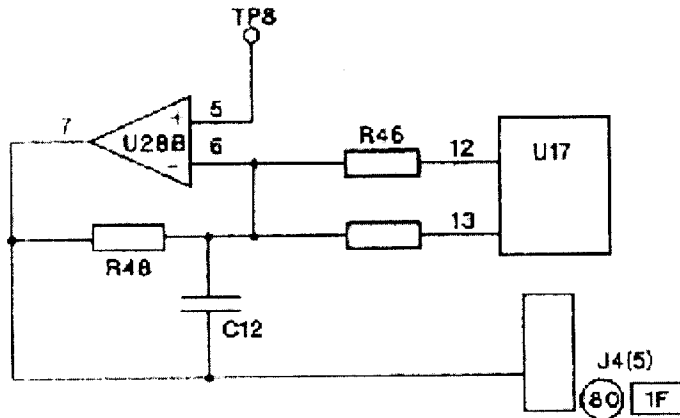

page 10.7-9, Schematic 3B

Figure 10.7-5:

change to read:

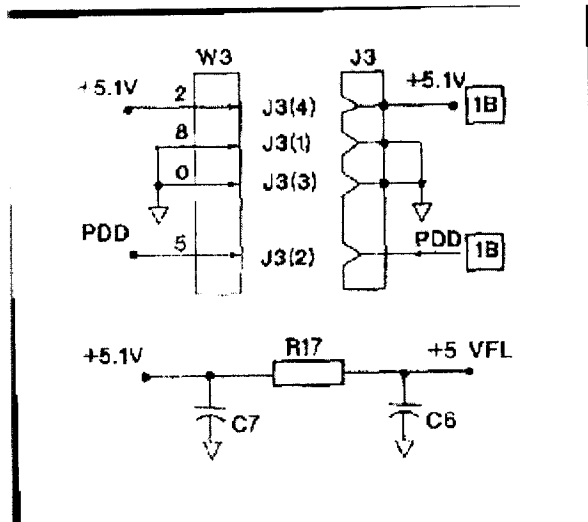

page A-2, Repl. Parts

ADD as a title:

MASTER PARTS:

page A-3, Replaceable Parts

Add as a title to the upper two figures:

MASTER PARTS (continued):

Add as a title to the third figure:

KEYBOARD PARTS (including Option 001):

MODEL 8116A

page A-5. Replaceable Parts

Table A-2:

Change to read / add:

Reference	HP Part No	CD	Qty	Description	Manufacturer	Part No
A0	8116A		1.00	Pulse/Func Gen	28480.00	8116A
A0 MP8	03478-88304	5.00	1.00	Bezel Rear		
A0 MP25	2110-0514	8.00	1.00	Fuse Holder Body		

page 8-17 "Procedure" shown in step 3. needs the limits changed to read:

HP 8116A Offset	Voltmeter reading
+ 7.95 V	+ 7.870 to 8.030 V
+ 5.00 V	+ 4.935 to 5.065 V
+ 2.00 V	+ 1.950 to 2.050 V
0.00 V	- 0.040 to + 0.040 V
- 2.00 V	- 2.050 to - 1.950 V
- 5.00 V	- 5.065 to - 4.935 V
- 7.95 V	- 8.030 to - 7.780 V.

page 8-39 "DC Output" change to read:

Offset	Minimum	MEASURED	Maximum	Uncertainty
+ 7.95 V	+ 7.870 V		8.030 V	
+ 5.00 V	+ 4.935 V		5.065 V	
+ 2.00 V	+ 1.950 V		2.050 V	
0.00 V	- 0.040 V		+ 0.040 V	
- 2.00 V	- 2.050 V		- 1.950 V	
- 5.00 V	- 5.065 V		- 4.935 V	
- 7.95 V	- 8.030 V		- 7.870 V	

page 9-5, Adjustment Procedures

step 22.

change to read:

Turn A1 R445 fully anti-clockwise and then adjust it to achieve an output amplitude of 1 V (5 divisions).

pages 8-22, and 8-24, Testing Performance

Exchange the figures between these pages.

Figure 8-13 should show the test setup with the oscilloscope.

Figure 8-14 should show the test setup with the spectrum analyzer.

page 9-18, Adjustment Procedures

Amplitude Modulator Adjustment:

Figure 9-4 is missing the test setup with the spectrum analyzer, as Figure 8-14, corrected above, shows.

Figure 9-4 should show both figures:

- A) As Figure 8-14 shows, a test setup with the spectrum analyzer
- B) As Figure 9-4 already shows, a test setup with the oscilloscope

page 2-13, Specifications add:

General
Characteristics
Capitel 2

DECLARATION OF CONFORMITY

(similar to ISO/IEC Guide 22)

Manufacturer: Hewlett-Packard GmbH
Boeblingen Instruments Division
Herrenberger Str. 130
D-71034 Boeblingen
Germany

we declare that the product

HP 8116A Pulse Generator

conforms to the following standards:

Safety: IEC 348 (1978)

EMC : EN 55011 (1991) / CISPR 11 Group 1, Class A
EN 50082-1 (1991)
IEC 801-2 ESD: 4kV cd, 8kV ad
IEC 801-3 Radiated Immunity: 3V/m
IEC 801-4 Fast Transients: 0.5kV, 1kV

Supplementary Information:

During the measurements against EN 55011, the I/O ports were terminated with their nominal impedance, the HP-IB connection was terminated with the cable HP 10833B. When the product is connected to other devices, the user must ensure that the connecting cables and the other devices are adequately shielded to prevent radiation.

Boeblingen, 25th August 1993
Hans Baisch
Product Regulations Consultant

On Figure 10.7-5, Schematic 3B, change to read:

Pin numbers of the inputs of U39D have to be exchanged

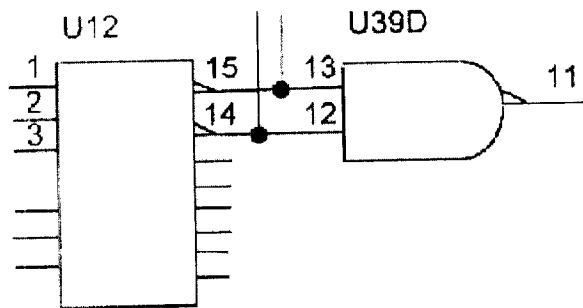

Pin numbers of R11 have to be changed to:

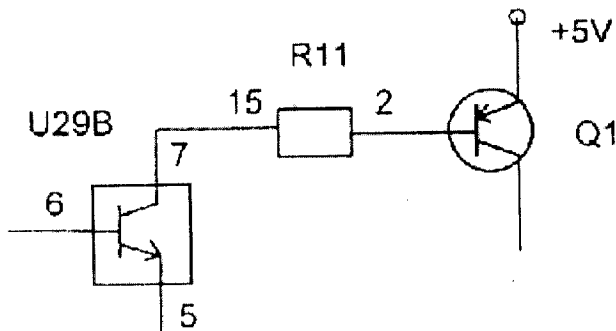

Page A-13, Replaceable Parts add

A1

MP211, 300, 401

1200-0541

IC SOCKET, 24PIN

MODEL 8116A

MANUAL CHANGE 1

On Page A-9, Replaceable Parts List, change to read:

EDC-LBL A-3135	A1	C300*	0160-5736	C-FXD 22PF
-------------------	----	-------	-----------	------------

On Page A-16, Replaceable Parts List, add:

A1	R20	0698-3438	R-FXD 147 1%
----	-----	-----------	--------------

NOTE: ONE SIDE OF R15 HAS TO BE SOLDERED INTO THE BOARD. INTO THE OTHER R15-HOLE R20 HAS TO BE SOLDERED. THE OTHER ENDS OF THE TWO RESISTORS HAS TO BE FIXED BY THE EYELET AND SOLDERED TOGETHER, FORMING A TEEPEE. Δ INSTEAD OF -5.2V POWER SUPPLY VOLTAGE -5.4V IS REQUIRED

On Page 9-3, Adjustment Procedures
in step 3:

Delete:	A1 -5.2V	A1R12	-5.250V \pm 10mV
Add:	A1 -5.4V	A1R12	-5.400V \pm 10mV

On Page A-21, change the Table of Replaceable Parts to read:

A1	R436*	0757-0200	R-FXD 5.62kohm
----	-------	-----------	----------------

On Page A-25, change the Table of Replaceable Parts to read:

A1	U300	1DD6-0002	IC 1DD6
----	------	-----------	---------

NOTE: EDC-LBL:Engineering Date Code
Label = Board Revision
+ Date Code

MODEL 8116A

MANUAL CHANGE 2

On Page A-6 Replaceable Parts change to read:

ADD:	MP60	0380-0643	SCREW,HPIB
	W1	5180-2471	HP-IB-ASSY

On Page's A-9/10/11/19 Replaceable Parts List change to read:

A-3213	Δ1	C406	0160-4547	CF 150pF
	Δ1	C531	0160-3872	CAP 2.2pF
	Δ1	C555	0160-4385	CAP 15pF
	Δ1	R228	0757-0346	RES 10 1%

MANUAL CHANGE 3

On Page A-7/A-8/A-9/A-10, Replaceable Parts to read:

Δ1	C18,C19,C102, C105,C110, C213,C226 C227,C240	0160-3097	CAP 0.47uF 50V
	C402,C404, C503,C504, C507,C508, C519-C522		

MANUAL CHANGE 4

On Page A-35, Replaceable Parts List, change to read:

A-3225	A3	U40	08116-10027	EPROM
--------	----	-----	-------------	-------

MODEL 8116A

MANUAL CHANGE 5

On Page A-33, change the Table of Replaceable Parts, Delete:

A3	J3	1251-3167	CONN-POST-TB
----	----	-----------	--------------

On Page A-35, change the Table of Replaceable Parts, ADD:

A3	W3	08116-61693	CBL BD AY's
----	----	-------------	-------------

On 8116A Manual Page 10.7-9 upper right corner correct Schematic as follows:

Color Signal W3 (J3) Pin	J3 from A1 Main Board
gray ground V-----> 1	>--V ground
green PDD -----> 2	>--- page 1B
black ground V-----> 3	>. V ground
red +5.1V O-----> 4	>--- +5.1V

MANUAL CHANGE 6

On Page A-34, Repl.Parts List change to read:

A-3405	A3	U10	1818-1768	IC HM6116LP-3
--------	----	-----	-----------	---------------

MANUAL CHANGE 7

On Page A-8 Repl.Parts List change to read:

A-3419	A1	*C217	0160-4380	CAP 1pF
--------	----	-------	-----------	---------

MANUAL CHANGE 8

On Repl.Parts List A-38, Table A-7 Parts List, change to read:

A-3550	A5	DS4,18	1990-1840	LED-LT BAR
		DS5,6,7	1990-1841	LED-LT BAR

On Repl.Parts List A-51, Table A-11 Parts List, change to read:

B-3550	A5	DS8,18	1990-1840	LED-LT BAR
		DS2,3,4,5,6,7	1990-1841	LED-LT BAR