

Fisher and Paykel washing machine motors for electricity generation

Applications:

- Wind generators
- Microhydroelectric generators
- Exercise bike generator
- Motor driven generator
- Scalelectric set generator
- Electric motor drive

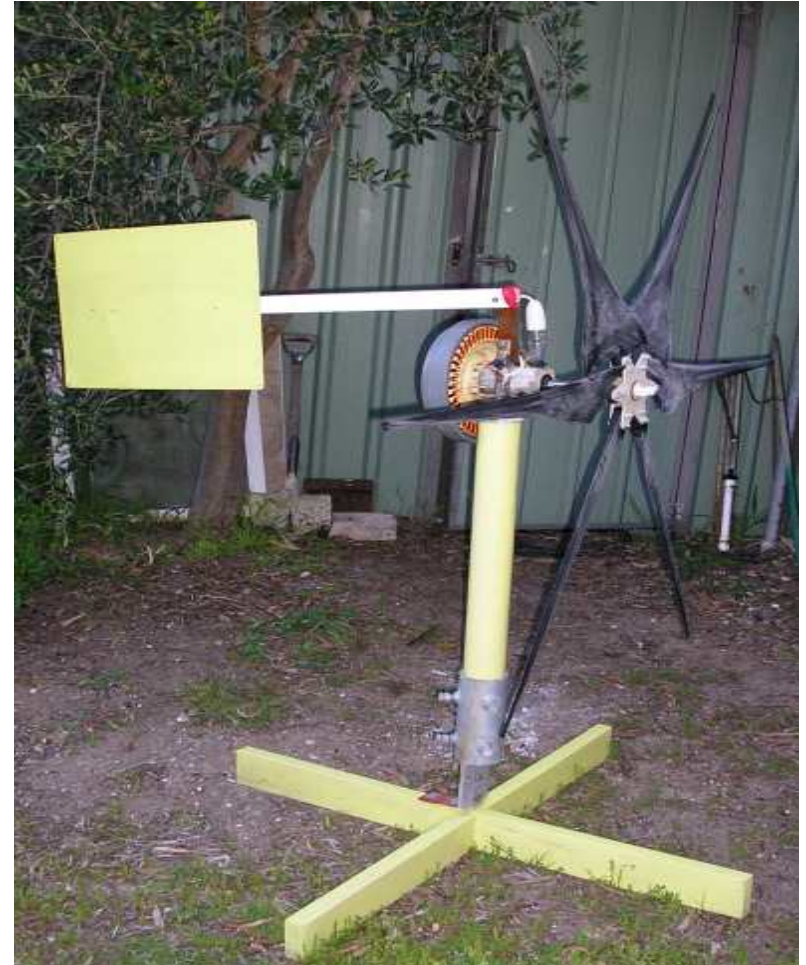

Generator using a Fisher and Paykel washing machine motors

- The Fisher and Paykel smart drive motor is a permanent magnet motor.
- Most electric motors used in household equipment do not have permanent magnets.
- The permanent magnets mean that these motors make good electricity generators.
- The motor generates 3 phase 150 V AC electricity (this can easily be altered with some rewiring).
- A 3 phase rectifier can be added to the motor output to make 150 V DC.
- Most household electric motors (brushed motors) will run on DC quite well.
- Induction motors like those in household fans will not run on DC.

Three phase rectifier added to generator from discarded Fisher and Paykel (FP) washing machine motor

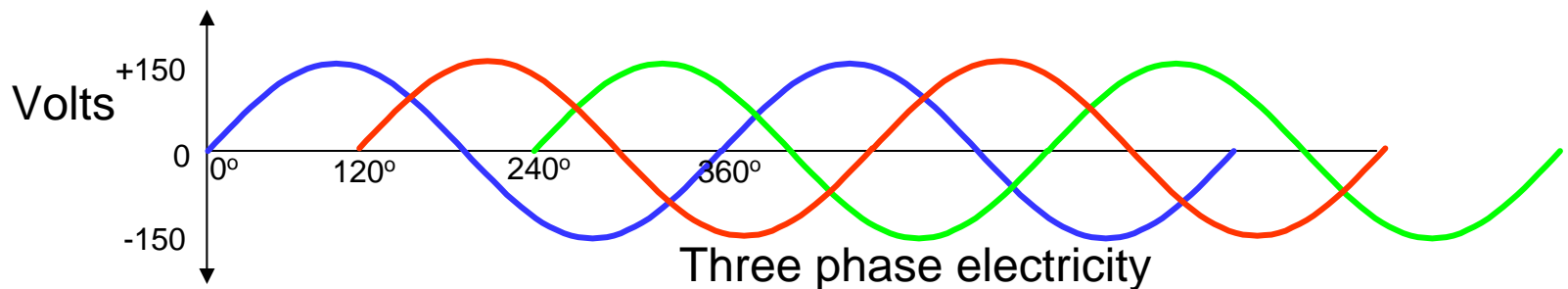
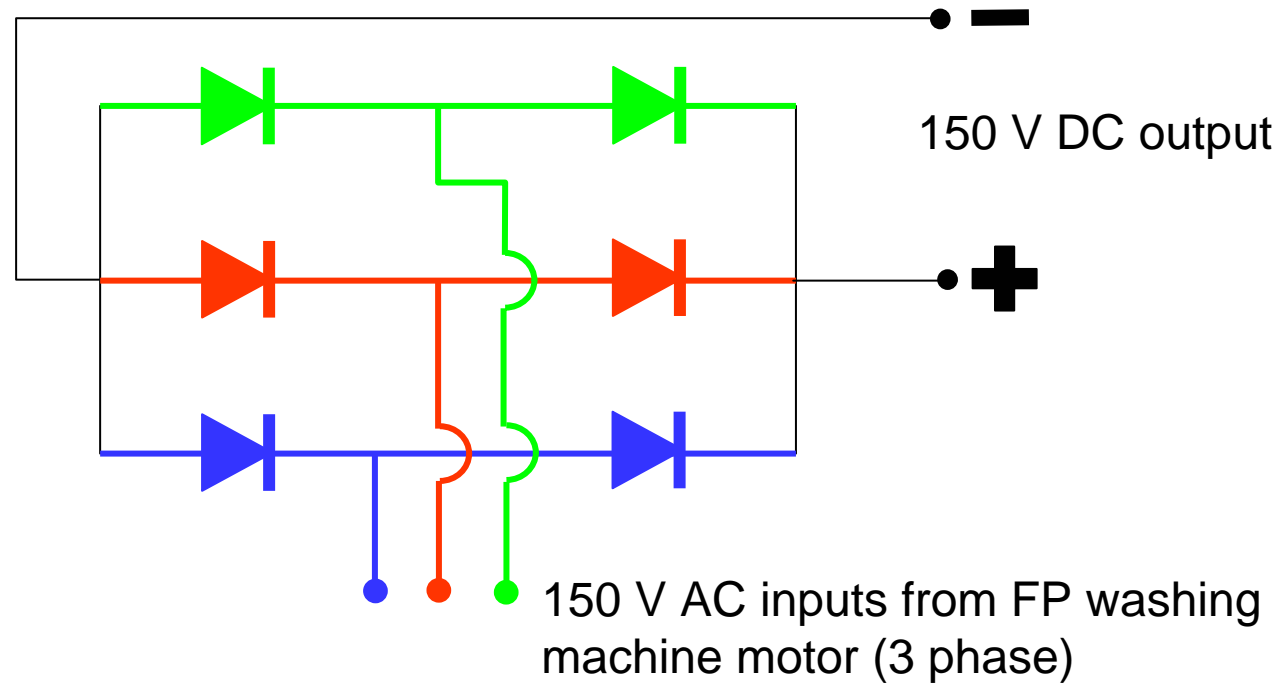

Removing the motor from a washing machine 1

Smart Drive washing machine can be dismantled in a matter of minutes.

- Remove the plastic top; unhook the 4 bowl hangers from inside and lift out the entire bowl as shown.
- Remove the cap from the top of the agitator, reach inside and undo the plastic nut that holds the agitator onto the shaft. Remove the agitator then undo the screws on the retaining ring.



Removing the motor from a washing machine 2

- Remove the stainless steel bowl from within the plastic outer bowl.
- Turn the unit over and work from the bottom, remove the magnetic plastic rotor. It should look like the picture below.

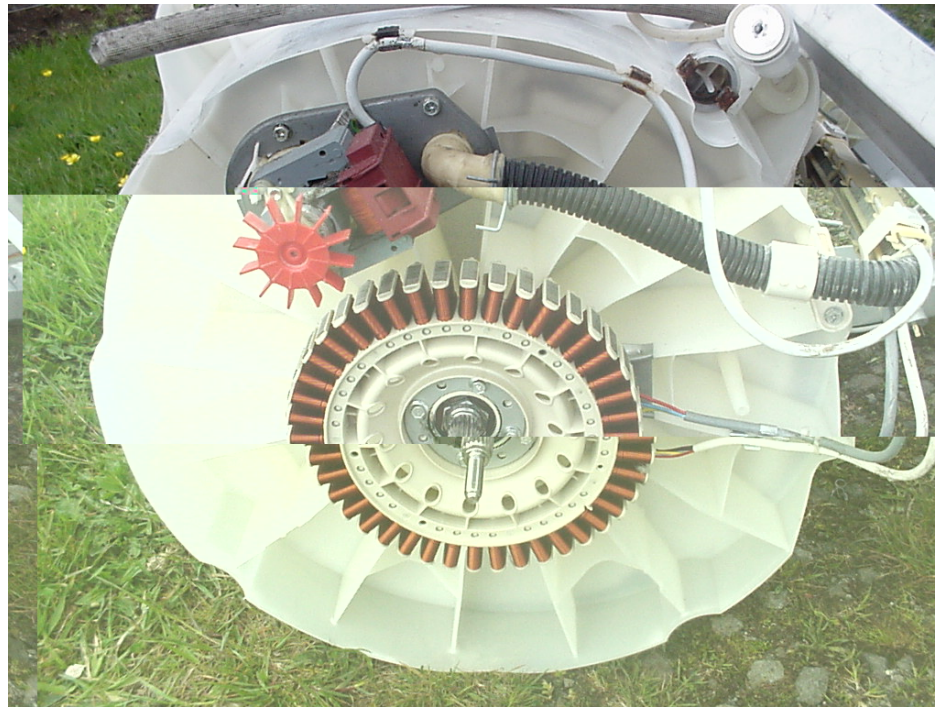

- Undo the four fixing screws that hold the copper wire wound stator onto the bearing assembly.

Removing the motor from a washing machine 3

- Cut out the bearing assembly from the plastic bowl with a saber saw.
- Most of the units you find will be about 10 years old and have 1.0mm wire size on the copper wound stator.
- In time more and more of the 0.8mm and 0.6mm versions will become available.
- These earlier units are very easy to reconnect as extensions are not required, cut wires can be unwound in both directions off each finger.
- There are three different wire sizes available 1.0mm, 0.8mm and 0.6mm.



Motor models

Model	Wire diameter (mm)	Configuration	Numer of turns	Effective wire area (mm²)	Max current (amps)
100 S	1.0	Series	616	0.79	8
100 SP	1.0	Series/Parallel	88	5.50	56
100 P	1.0	Parallel	44	11.00	112
80 S	0.8	Series	1610	0.50	3
80 SP	0.8	Series/Parallel	230	3.52	21
80 P	0.8	Parallel	115	7.04	42
60 S	0.6	Series	2380	0.28	3.5
60 SP	0.6	Series/Parallel	340	2.00	25
60 P	0.6	Parallel	170	4.00	50

Table 1. Smart Drive generator winding connection options.

Output from different wiring configuration of the motor

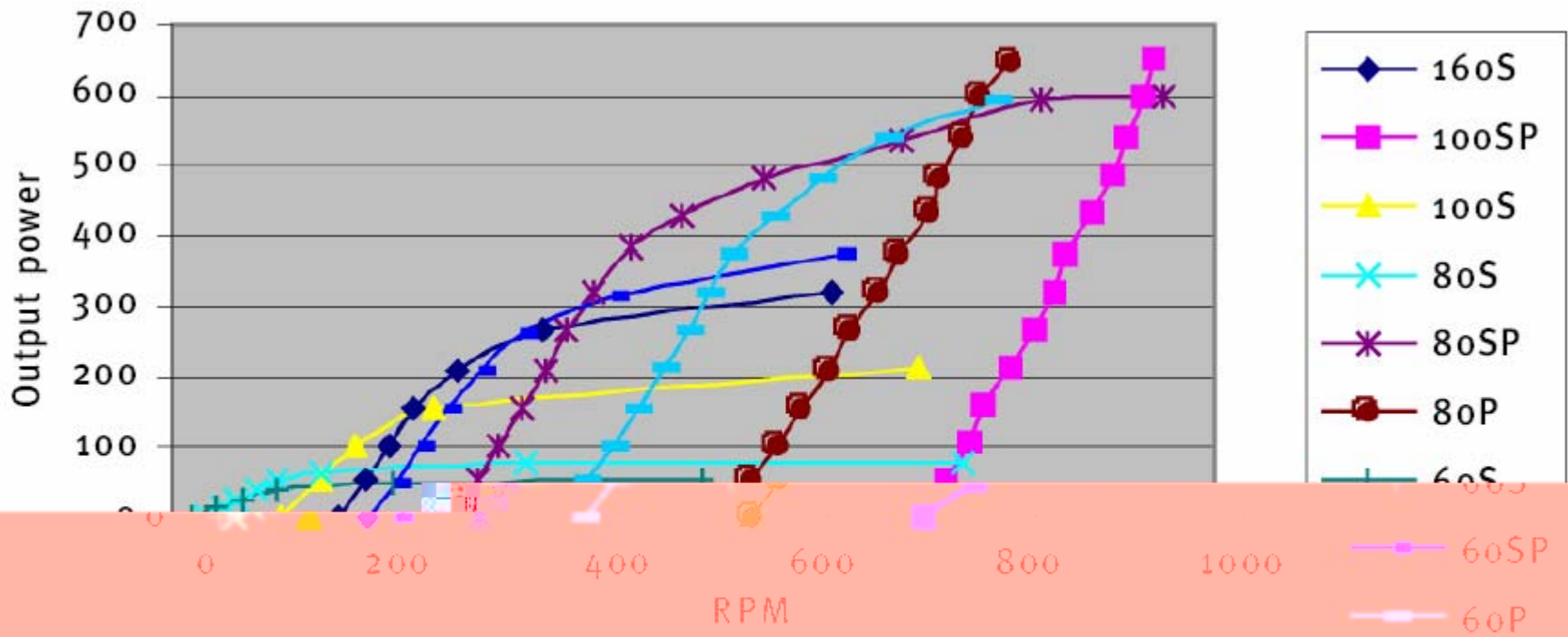
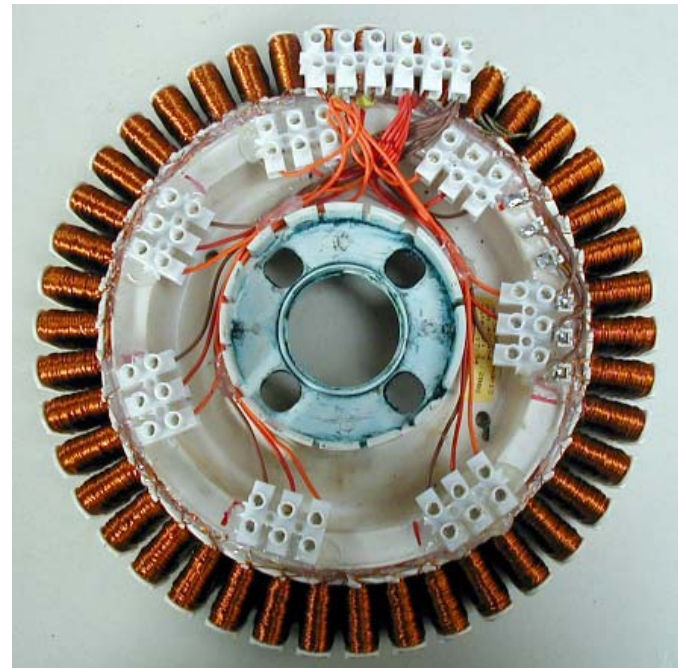
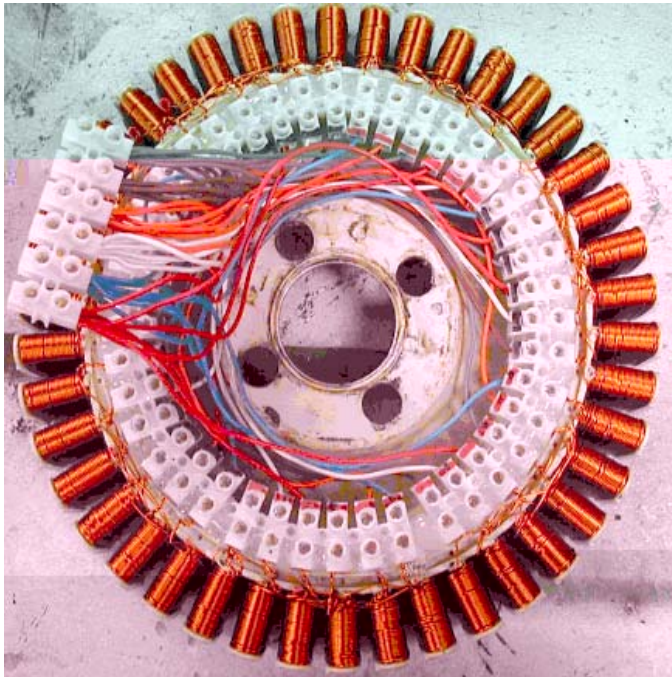

Figure 1. Smart Drive performance curves for a 24 volt system using a star wiring configuration.

Configuring stators

- The stators can be reconnected in numerous configurations including series/parallel (left) and parallel (right)



Wind generator

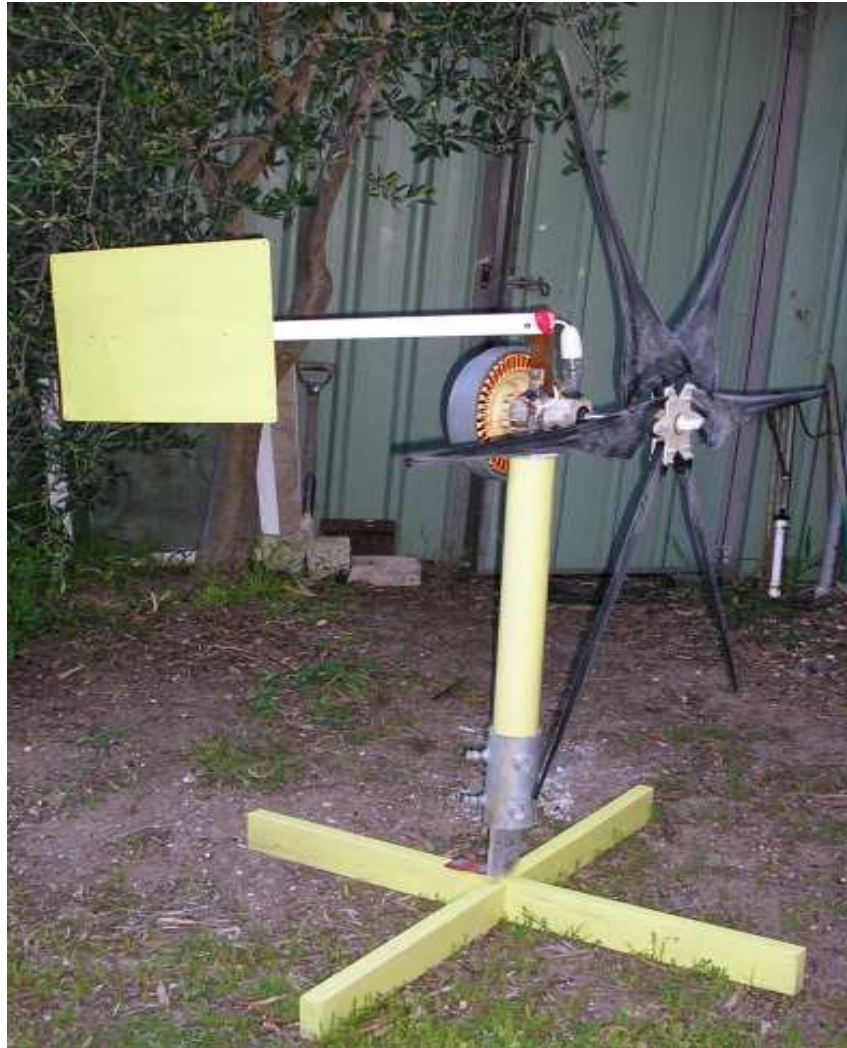



3 inch galvanised steel pipe pole

The bits can be assembled at a venue in 2 minutes



Blades and mounting plates from Ecoinnovation
www.ecoinn.co.nz

Detail, original Bearing mount used

Vertical bearing is from a second washing machine

3 phase rectifier is 1 ½ bridge rectifiers









Cogging

- Resistance of the Smart Drive rotor to turn freely from the stationary position.
- Once moving, this resistance drops away to almost nothing.
- Seriously affects - the blade is reluctant to start rotating.
- All wind turbine blades are reluctant to start (as the wind direction is not correct in relation to the blades until the blades start to move).
- Smart Drive motor (without a decogged stator) will not start until wind speeds reach about 28 to 30km/h (1.5 metre, six-bladed high torque prop) - is far too high to be of any use.
- Decogged will start rotating in wind speeds around 18km/h (5m/s). Once the blades start they keep going until the wind drops to about 15km/h.
- Power output approximately 400 Watts at 36km/h (10m/s)
Maximum output of 700 Watts (over 50km/h, or 14m/s)

Decogging

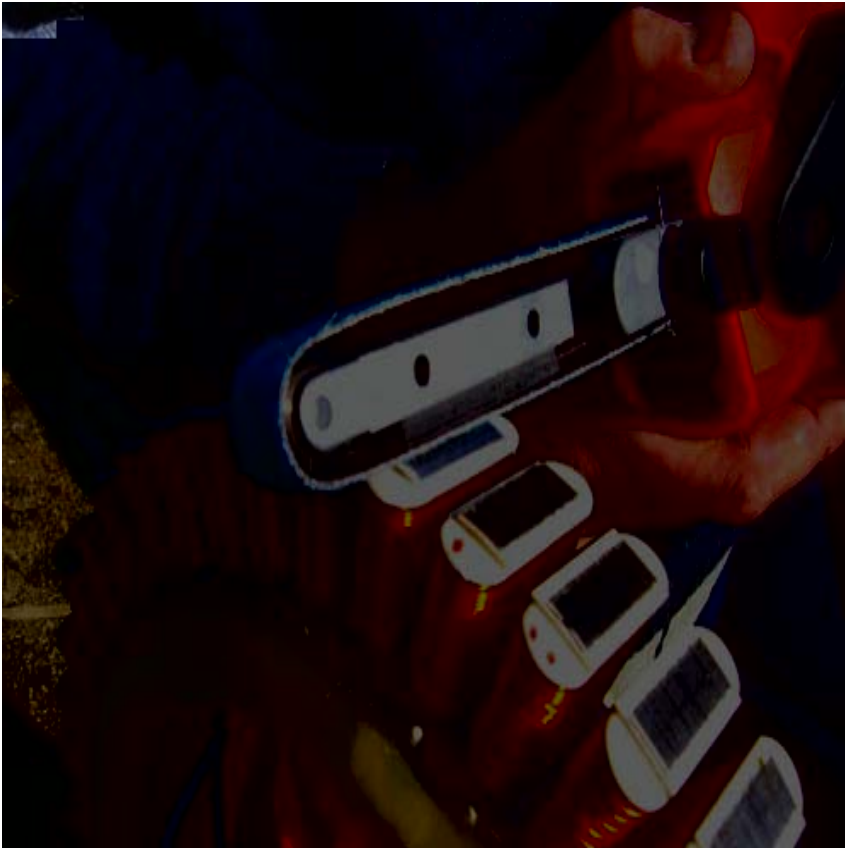

Microhydroelectric generator



Microhydroelectric generator

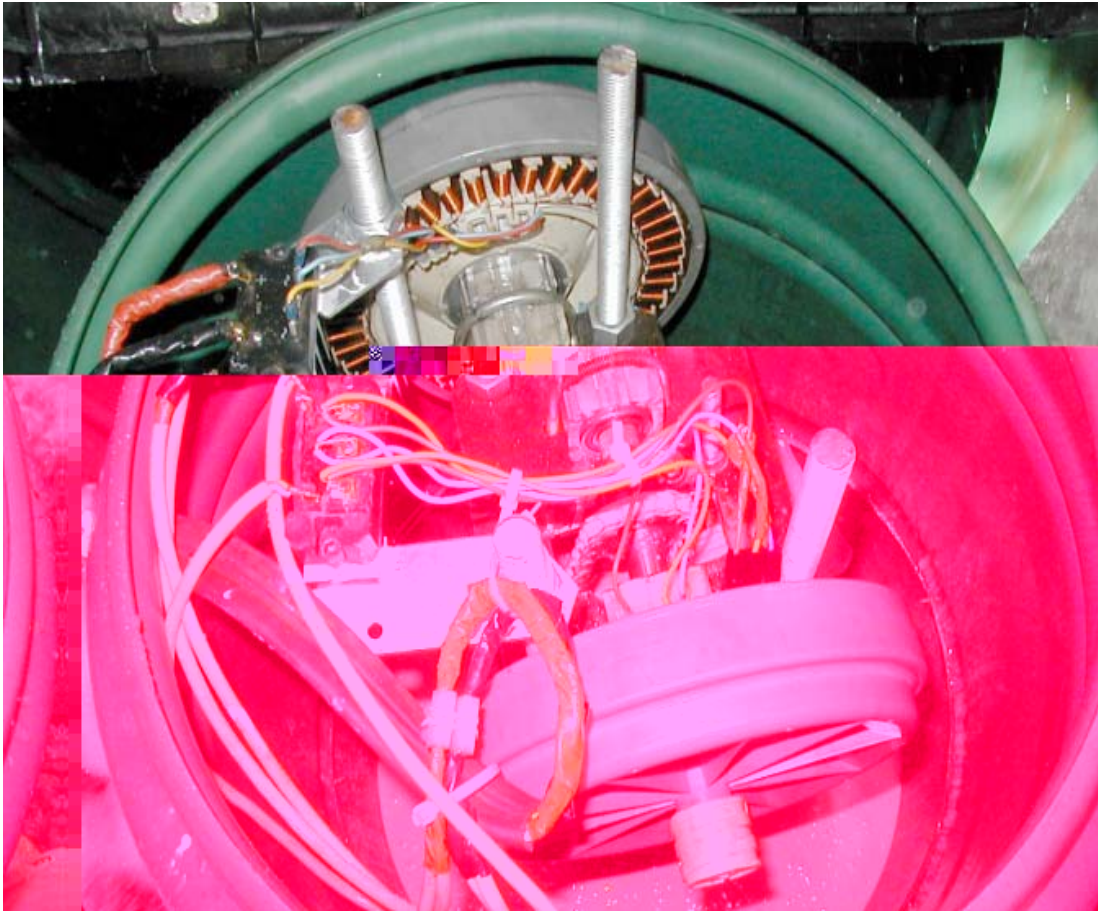





Petrol motor electric generator

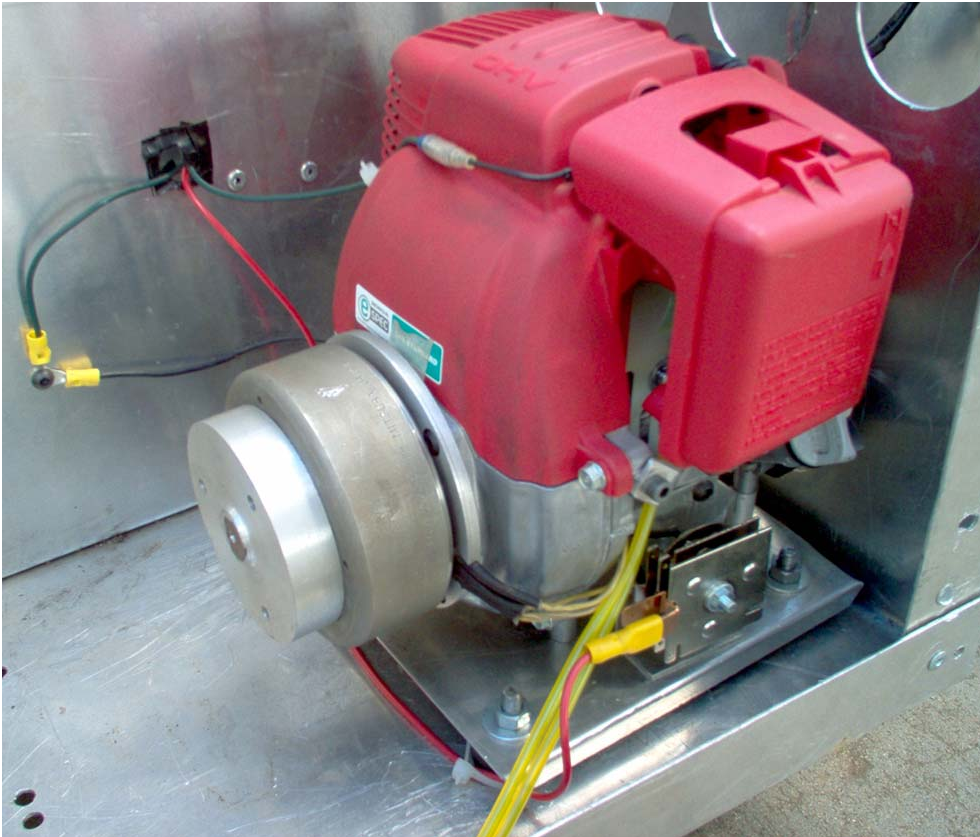

Scalelectric set generator



Other issues

- Ultraviolet light and rain cover
- The Smart Drive plastic rapidly degrades in sunlight and will crack, so keep it covered. A bucket is cut to fit is good.
- Rain will rust the metal winding pegs.

Reference information

- Making Smart Drives smarter, Michael Lawley, Vol 89 page 62 Oct 2004
- An argument for micro-hydro, Jeffe Aronson, Vol 84, page 66, July 2003
- Making a small, portable backup generator, Warwick Smith, Vol 87, page 49, April 2004

Ecolnno EcoInnovation are available from Michael Lawley, EcoInnovation, 671 Kent Rd RD1, New Plymouth, New Zealand, ph:(NZ)06 752 2765, ecoinn@paradise.net.nz, www.ecoinn.co.nz

Contact: Jonathon Thwaites, <http://www.sustainability.fm.uwa.edu.au>

end

Exercise bike generator using a Fisher and Paykel washing machine motor

- The Fisher and Paykel smart drive motor is a permanent magnet motor.
- Most electric motors used in household equipment do not have permanent magnets.
- The permanent magnets mean that these motors make good electricity generators.
- The motor generates 3 phase 150 V AC electricity (this can easily be altered with some rewiring).
- This motor has a 3 phase rectifier on its output to make 150 V DC
- Most household electric motors (brushed motors) will run on DC quite well.
- Induction motors like those in household fans will not.

Three phase rectifier added to generator from discarded Fisher and Paykel (FP) washing machine motor

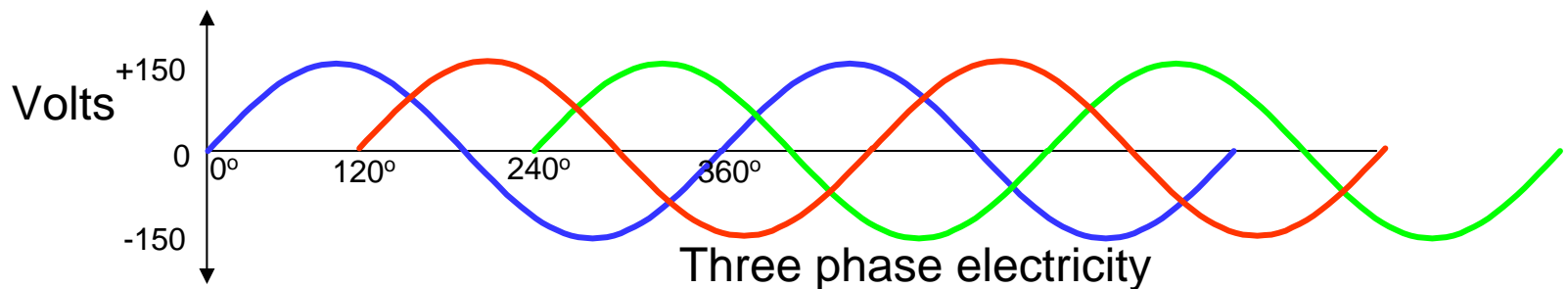
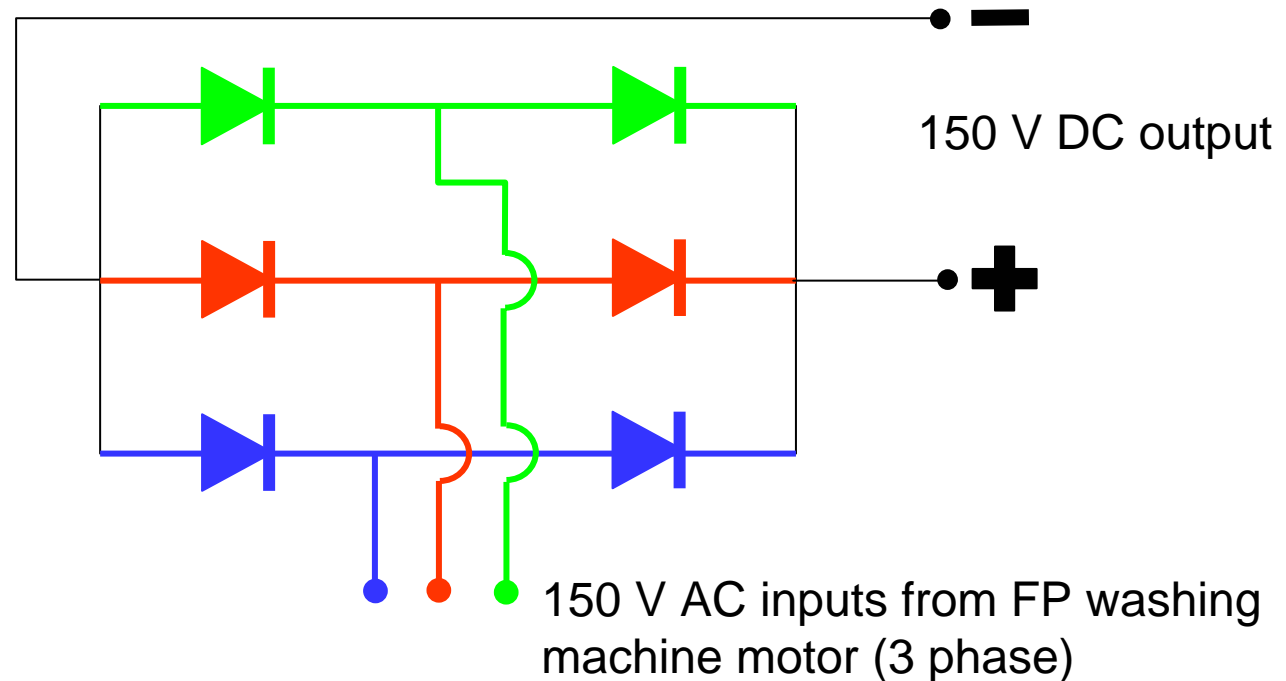

Contact:

Jonathon Thwaites, <http://www.sustainability.fm.uwa.edu.au>

Wind turbine using a Fisher and Paykel washing machine motor

- The Fisher and Paykel smart drive motor is a permanent magnet motor.
- Most electric motors used in household equipment do not have permanent magnets.
- The permanent magnets mean that these motors make good electricity generators.
- When a magnet passes by a wire it induces a current in it.
- The permanent magnets in the rotating drum part of the motor pass by the coils of wire on the metal spindles of the stationary part of the motor inducing currents in the coils of wire.
- Coils are used so that the length of wire passing the magnet is longer and the current induced larger.